

Ampco Pumps Company

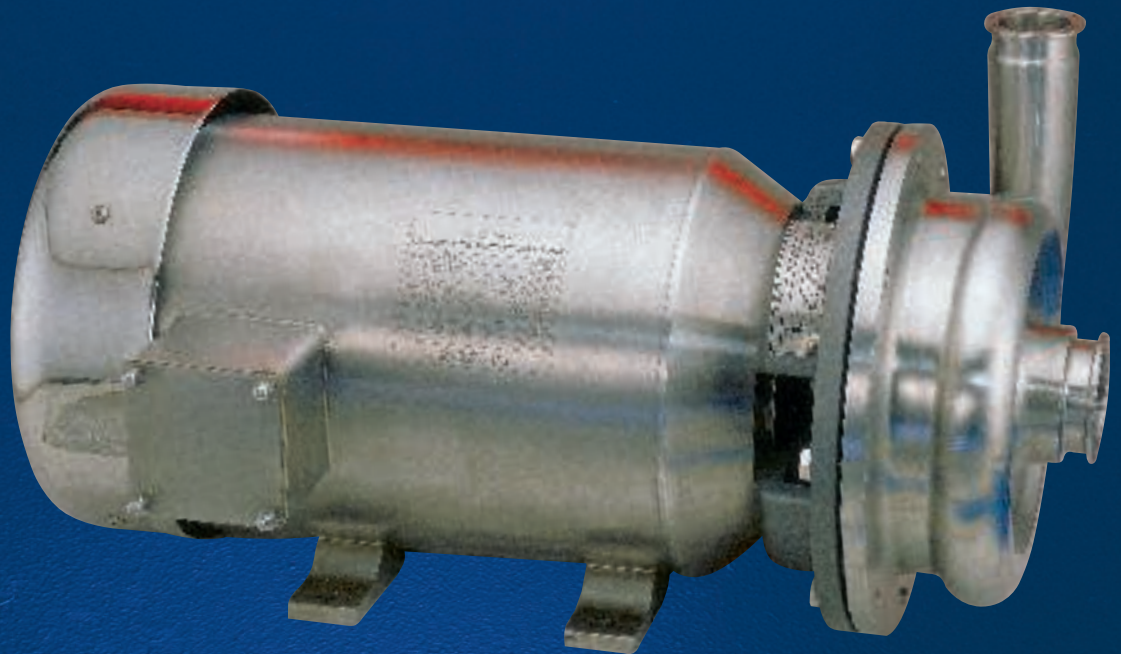

**Sanitary Centrifugal Pumps
for CIP/COP and Product
Handling Applications**



Sanitary Stainless Steel Pumps For CIP/COP and Product Handling Applications

The Ampco line of stainless steel centrifugal pumps have been in use in dairy and food processing plants since 1957 when a Z Series flanged unit was installed on a first generation CIP system. In the mid-eighties, Ampco developed the D Series, designed principally for CIP and COP systems. Efficient performance, quiet operation and low maintenance requirements soon made Ampco's DC2 the preferred pump in the CIP/COP market.

D Series

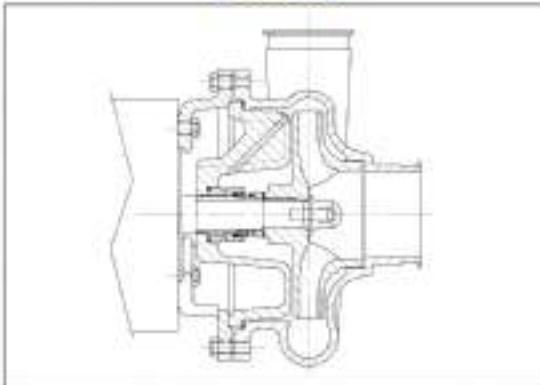

Ampco's DV Series, with a unique double volute design, is ideally suited for CIP return applications. The double volute design reduces air binding without an air relief valve at half the cost of a "self-priming" pump.

In 1997, Ampco introduced the DC3 Series, the first pump approved under 3A Sanitary Standards for Centrifugal and Positive Rotary Pumps for Pumping Cleaning and Sanitizing Solutions, Number 47-00. The DC3 Series, with the same performance characteristics as the reliable DC2 Series plus an improved sanitary seal design, offers food and dairy plants a cost effective option to meet the new 3A Sanitary Standards.

Ampco's M Series pumps, with superior hydraulic design and stringent manufacturing standards, offer a level of performance and reliability unsurpassed in the sanitary pump market. The MC3 Series, introduced in 2004, offers an improved external seal arrangement with a clamped-in silicon carbide seat. Surface finishes range from 32 RA (150 grit) to 12 RA (320 grit). Ampco's M Series pumps are in conformance with 3A Sanitary Standards for Centrifugal Pumps for Milk and Milk Products, Number 02-09.

M Series

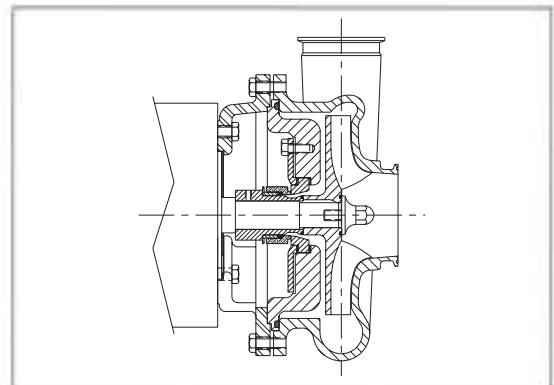

Ampco Pumps are individually assembled to meet customer specifications and tested before shipment to verify hydraulic, mechanical and electrical performance. Delivery time for standard pumps is one week or less.

In addition to the D Series and M Series, Ampco offers a wide range of centrifugal pumps in both nickel aluminum bronze and stainless steel.

For additional information, call or write to:

Ampco Pumps Company
2045 W Mill Road
Glendale, WI 53209
Phone: (414) 643-1852
Fax: (414) 643-4452
www.ampcopumps.com

AMPCO M Series

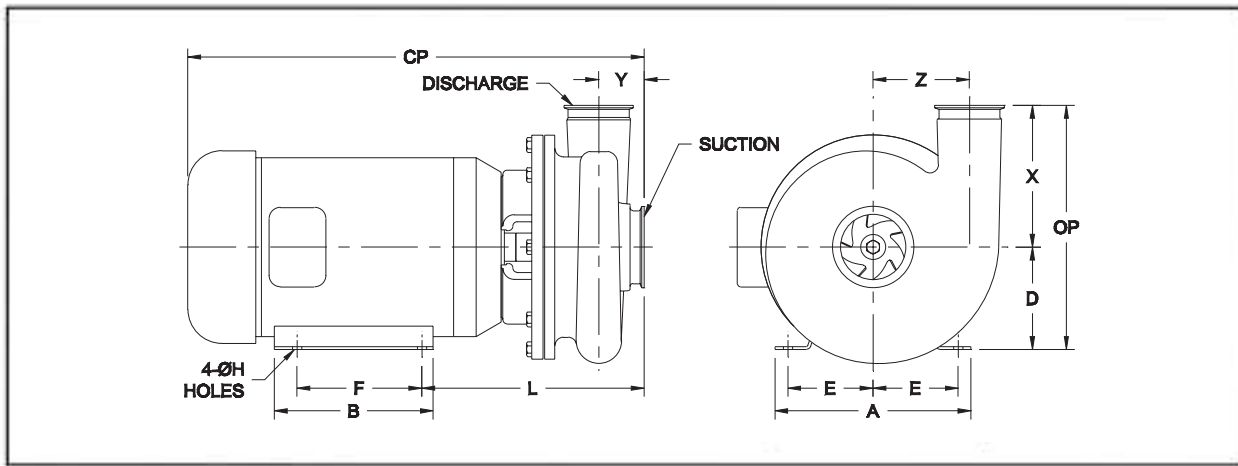

PUMP	MOTOR				DIMENSIONS IN INCHES												
	HP		RPM	Frame	(For reference only unless this sheet is certified and endorsed by Ampco)												
	Wash Down	TEFC			A (max)	B (max)	D	E	F	H	L	CP	OP	C	Suction	Discharge	
2 x 1½	10	7½	3500	213	10½	8	5¼	4¼	5½	13/32	10 ⁵ / ₁₆	22 ⁵ / ₁₆	11½	3¾	2	1½	
	7½	5	3500	184	9	6¾	4¼	3¾	5½	13/32	9 ⁹ / ₁₆	21½	10¾	3¾			
	5	3	3500	182	9	6¾	4¼	3¾	4½	13/32	9 ⁹ / ₁₆	21½	10¾	3¾			
	3	3	1750	182	7	6	3½	2¾	5	11/32	8 ²³ / ₃₂	18 ⁹ / ₁₆	9¾	3¾			
	3	2	3500	145	7	6	3½	2¾	5	11/32	8 ²³ / ₃₂	18 ⁹ / ₁₆	9¾	3¾			
2½ x 2	15	10	3500	215	10½	8	5¼	4¼	7	13/32	10¼	22¾	11½	4	2½	2	
	10	7½	3500	213	10½	8	5¼	4¼	5½	13/32	10¼	22¾	11½	4			
	7½	5	3500	184	9	6¾	4¼	3¾	5½	13/32	9½	21 ³ / ₈	10¾	4			
	5	-	3500	182	9	6¾	4¼	3¾	4½	13/32	9½	21 ³ / ₈	10¾	4			
	3	3	1750	182	9	6¾	4¼	3¾	4½	13/32	9½	21 ³ / ₈	10¾	4			
3 x 2½	15	10	3500	215	10½	8	5¼	4¼	7	13/32	10 ⁷ / ₈	22 ⁵ / ₈	11½	4½	3	2½	
	10	7½	3500	213	10½	8	5¼	4¼	5½	13/32	10 ⁵ / ₈	22 ⁵ / ₈	11½	4½			
	7½	5	3500	184	9	6¾	4¼	3¾	5½	13/32	9 ⁷ / ₈	21¾	10¾	4½			
	5	-	3500	182	9	6¾	4¼	3¾	4½	13/32	9 ⁷ / ₈	21¾	10¾	4½			
	3	3	1750	182	9	6¾	4¼	3¾	4½	13/32	9 ⁷ / ₈	21¾	10¾	4½			
3 x 2½	2	2	1750	145	7	6	3½	2¾	5	11/32	8¾	18 ⁷ / ₁₆	9¾	4½			

M SERIES - SANITARY PUMPS

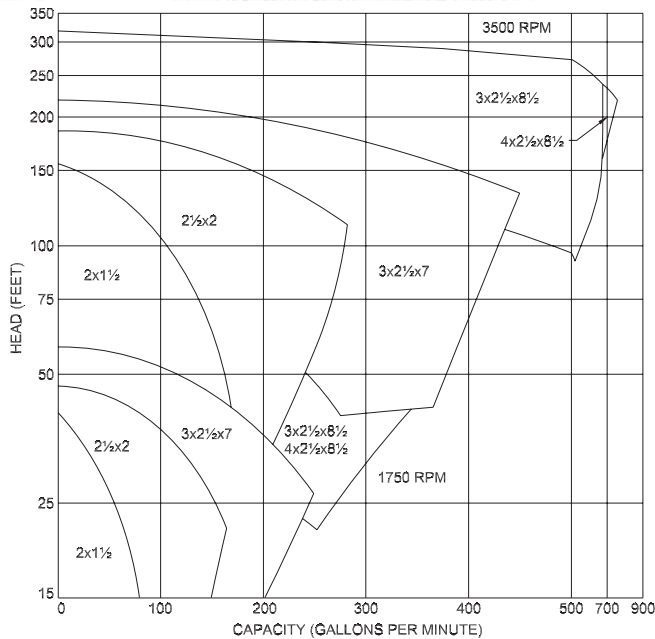

Characteristics Include:

- 3A conformance for handling product (02-09)
- Seal options
 - Standard T-8B2 external seal
 - Single or double internal seal
 - Various seal materials
- Efficient, Francis style semi-open impeller design
- Standard 32 RA (150 grit) surface finish with optional surface finishes from unpolished to 12 RA (320 grit)
- Minimum NPSH requirements
- Allowable working pressure to 125 PSI
- Temperatures to 250° F
- Closed coupled to NEMA Standard 'JM' motors

AMPCO D Series

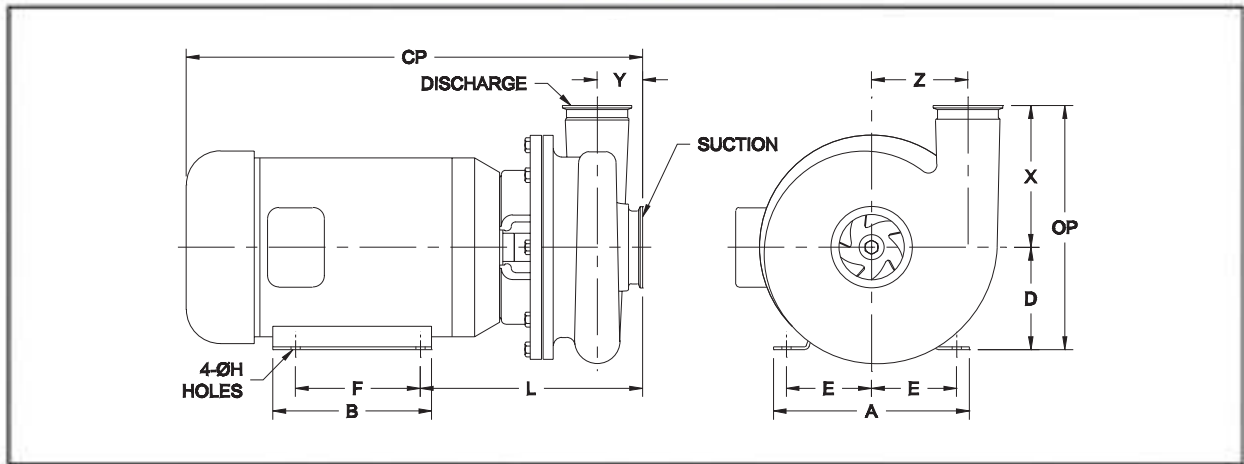

D SERIES—CLEANING/SANITIZING SOLUTION PUMPS

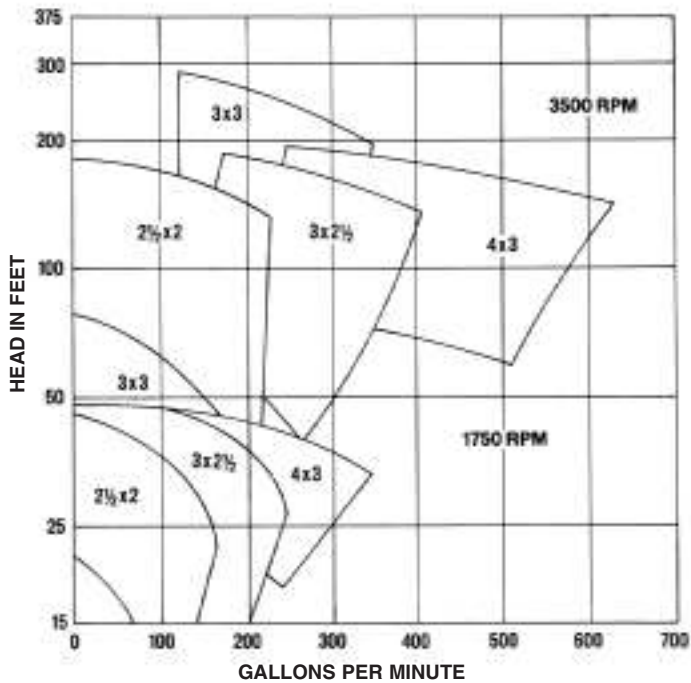

Characteristics Include:

- 3A conformance for CIP/COP systems (47-00)
- Double volute design is available to reduce air binding
- Optional mechanical seal materials
- Enclosed impeller design
- Surface finish better than SIS #1
- Allowable working pressure to 125 PSI
- Temperatures to 250° F
- Closed coupled to NEMA Standard 'JM' motors