



FLOW
LEVEL
PRESSURE
ANALYTICAL
TEMPERATURE
INSTRUMENTATION
PASTEURIZATION CONTROLS

AV-9900 HTST Recorder Controller

- New four color recording technology prints all trends, scales, events and customer specific messages on a plain paper, 12" chart.
- Hot product, cold product, hot water, and flow-rate all recorded and/or controlled in a single unit.
- Meets all PMO requirements for HTST, HHST, and UHT applications.

The AV-9900 HTST recorder controller is specifically designed for use in continuous pasteurization applications. The unit combines failsafe protection for the pasteurization process with the broadest range of configuration options ever available in an HTST control package. This is accomplished via a unique, four color printing technology which prints on plain paper, 12", 100 division charts. Each unit is programmable for up to 4 independent recording ranges and input types. Each scale is color coded to its' trend pen to provide a chart that is simple to read, even with multiple variables.



The standard unit provides legal Safety Thermal Limit Recorder (STLR) functionality with up to 5 selectable diversion setpoints. Remote selection of these setpoints is available as an option. Product temperature is monitored via our time proven dual element, 1,000 ohm RTD sensor. The STLR monitors sensor balance between the two elements to insure failsafe operation. The hot product scale, temperature, and flow diversion valve frequency trend are printed in red. When configured for multiple divert, the activated setpoint temperature is

continuously printed in green.

The unit can be optionally specified to include hot water control (HWC). This variable is normally displayed and controlled, but not recorded. For multiple divert applications, separate hot water setpoints can be programmed to be selected automatically when the diversion setpoint is changed.

Cold product can be optionally specified for Recording (CPR), or Recording/Controlling (CPRC). The range for this function is programmable to

provide maximum readability in the product range while including CIP temperature. The standard color for this variable is blue.

Now available with a Safety Flow Limit function for systems with meter based timing. This option can include Recording (SFLR) or Recording and Control (SFLRC). Range can be configured in percent flow or engineering units (GPM etc.). The standard color for this function is black.

AV-9900 Recording Controller Specifications

PERFORMANCE

Recording Accuracy:

±0.3% of chart span reference accuracy

Operating Temperature:

0 to 50°C (32 to 122°F)

Humidity:

10 to 90% RH, non-condensing

Warranty:

2 years

Agency Approvals:

UL approved in the USA, UL certified for Canada

INPUTS

STLR Input:

Dual Element, 1,000 ohm, 3-wire

Hot Water & Cold Product:

Single Element, 100 ohm, 3-wire or 4-20mA, 2-wire

Flow Rate:

4-20mA, 2-wire

OUTPUTS

A total of four on/off relay outputs and up to four 4 to 20mA analog outputs are available.

STLR Relay:

DPDT, 5 amps at 115 VAC, 2.5 amps at 230 VAC

Relay Outputs:

SPDT, contacts rated 5 amps resistive at 115 VAC, 2.5 amps resistive at 230 VAC.

POWER

AC Power:

115 or 230 VAC, ±15%, 50/60 Hz, auto-switching.

PHYSICAL

Overall Dimensions:

14.12 inches wide x 17.04 inches high x 7.75 inches deep :
(358.65mm wide x 425.96mm high x 196.85mm deep)

Panel Depth:

5.25 inches (133.35mm)

Panel Cutout:

12.7 inches wide x 12.7 inches high (322.58mm X 322.58mm)

Front Panel Protrusion:

2.5 inches (63.5mm)

Weight:

25 lbs. maximum (55 kg)

Vibration:

3 to 100 Hz @ 0.2g

Enclosure:

Gasketed cover, case and windows. Structural foam case, cover material with plastic window areas, NEMA 4X.

Mounting:

Universal, Panel or wall.

Chart:

12" diameter, 100 linear divisions

DISPLAY AND KEYPAD

Primary Display:

2 line, 40 character vacuum fluorescent display with characters .21 inches (5 mm) high.

MATRIX

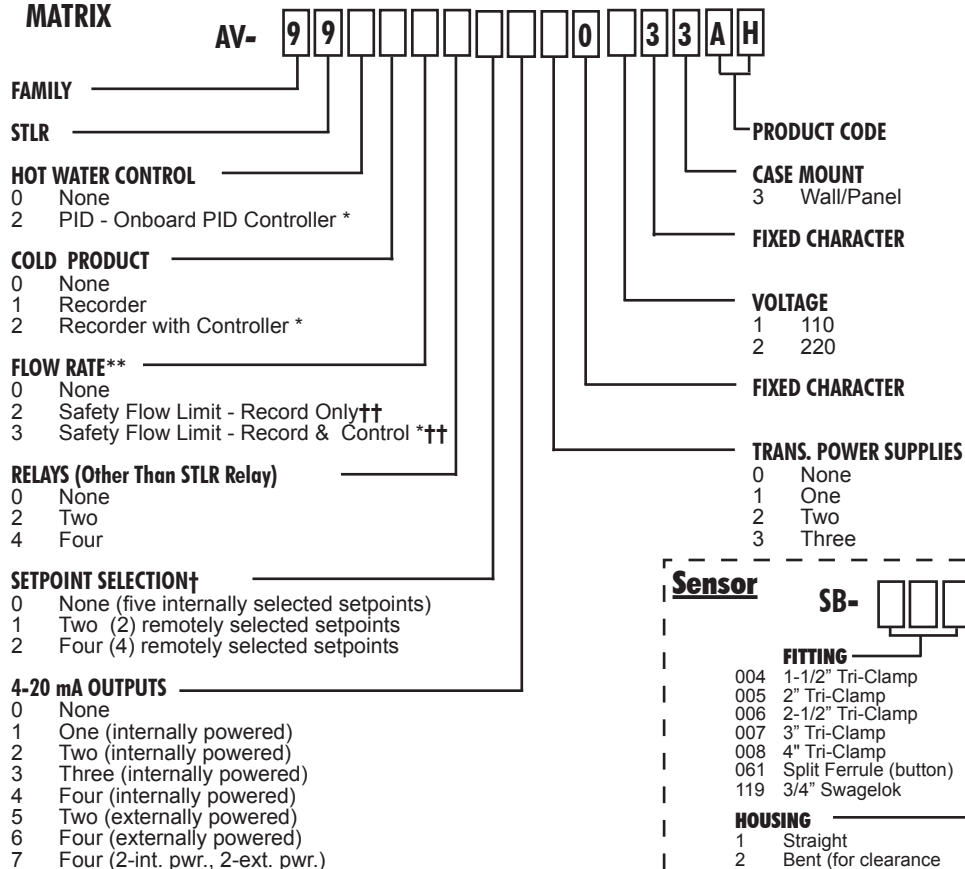

* Must specify one mA output for each of the following additional functions specified.

Hot Water Control - Option 2
Cold Product - Option 2
Flow Rate - Option 3

** Consult factory for compliance status.

† If option (1) or (2) is selected, local setpoint select is disabled.

†† This option requires at least 2 relays, High and Low flow cutout.

Charts: Order #00215401

Note: Request worksheet 1029 for additional information required prior to order acceptance.

