

M-5000TG Wall-Mounted Series

This unit produces hot water instantly from a steady supply of steam and cold water. All mixing units-hose stations in the M-5000TG/M-5700TG series are equipped with a dial-type gauge that indicates the wash water's exact temperature. Users can easily regulate the temperature by turning the unit's steam and cold water valves. As an added safety measure, these units shut off their steam source automatically if the cold water supply falls below 50 psi for any reason. This prevents hazardous steam from exiting the unit and causing steam burns.

Please review the chart below before purchasing an M-5000TG/M-5700TG unit.

REQUIRED STEAM MODEL NUMBER	REQUIRED STEAM PRESSURE*	REQUIRED WATER PRESSURE*	GPM
M-5000 L**	80-95 lbs.	50-80 lbs.	5-7
M-5000 M	96-130 lbs.	50-80 lbs.	4½-6
M-5000 H	131-150 lbs.	50-80 lbs.	4½-6

The M-5000 unit is available in bronze or chrome-plated material.

**Steam pressure required at installation site to ensure proper operation of mixing unit.*

*** Standard unit supplied.*



Shown: M-5000TG, bronze; shown with premium hose assembly and M-70 Series nozzle
Available: M-5700TG, stainless steel

Specifications

- ◆ **Maximum water temperature:** 200°F/93°C
- ◆ **Maximum working pressure:** 150 psi steam

Please see reverse side for parts listing.



USA Headquarters

2801 Baglyos Circle ♦ Bethlehem, PA 18020

Phone: (484) 893-5080 ♦ Fax: (484) 893-5099 ♦ Toll Free: (877) STRAHMAN

www.strahmanvalves.com

France

Savoie Hexapole, F-73420 Mery, France

Tel: 33 (0) 4 79 35 78 00

Fax: 33 (0) 4 79 35 78 20

Germany

Zum Schwarzhof 14, 77704, Oberkirch, Germany

Tel: 49 (0) 7802 - 7037879

Fax: 49 (0) 7802 - 7037889

M-5000TG Wall-Mounted Series

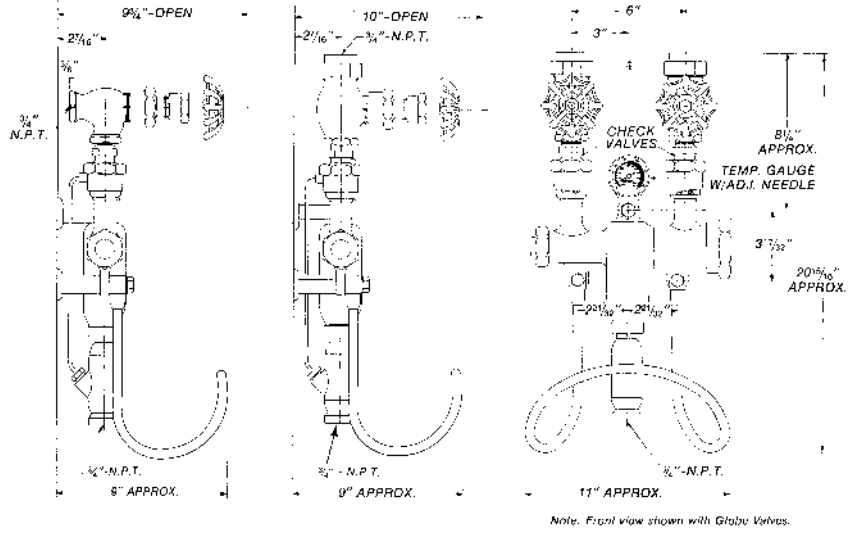
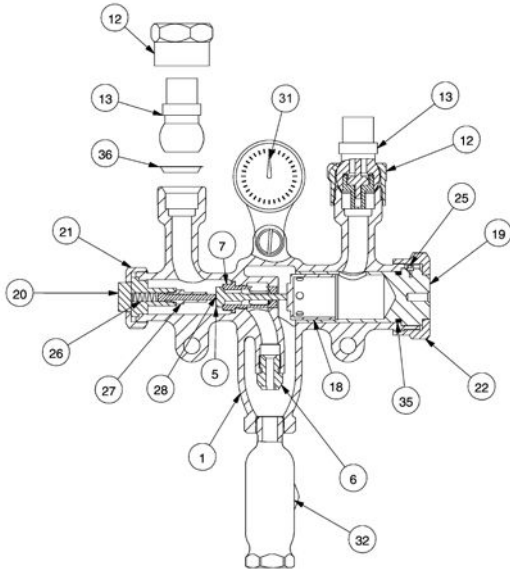

Note: Front view shown with Globe Valves.

PARTS

PART NO.	PART	M-5000 MATERIAL	PART NO.	PART	M-5000 MATERIAL
1	BODY (includes parts 6 and 7)	BRONZE	19	WATER CHAMBER HOUSING (includes part 35)	BRASS
2	HOSE RACK CAP SCREW (not shown)	STAINLESS STEEL	20	POPPET GUIDE	BRASS
3	HOSE RACK LOCK WASHER (not shown)	STAINLESS STEEL	21	POPPET GUIDE NUT	BRASS
4	HOSE RACK CONNECTOR (not shown)	BRASS	22	BODY NUT	BRONZE
5	STEAM POPPET (L, M, H)	STAINLESS STEEL	25	SET SCREW	STAINLESS STEEL
6	STEAM JET	STAINLESS STEEL	26	POPPET SPRING	STAINLESS STEEL
7	POPPET SEAT	STAINLESS STEEL	27	GUIDE EXTENSION	STAINLESS STEEL
8	HOSE RACK (not shown)	STAINLESS STEEL	28	PUSHER	STAINLESS STEEL
10	SPACER (not shown)	STAINLESS STEEL	31**	TEMP GAUGE	CHROME
11	WALL PLATE (not shown)	BRASS	35	"O" SEALING RING FOR WATER CHAMBER HOUSING	E5 15-80-2Q75
12	BALL CHECK UNION NUT	BRASS	36	BALL CHECK GASKET	COPPER, TEFLON COATED
13†	BALL CHECK VALVES (includes part 36)	BRASS/STAINLESS STEEL ALUMINUM SILICONE BRONZE			
18	WATER CHAMBER	STAINLESS STEEL			

†Sold as a complete unit.

**Temperature gauge: 40-120°C/100-250°F.