

# M-750TG Mixing Units-Hose Stations

Strahman **M-159** (bronze) and **M-750** (stainless steel) Mixing Units-Hose Stations are designed to thoroughly mix hot and cold water in any desired proportion. Available in both standard **M-159**, **M-750** and **M-159TG**, **M-750TG Series**.

Our Temperature Indicating (**TG**) models are equipped with a blending chamber and quick acting dial-type dual Fahrenheit and Centigrade temperature gauge, which accurately indicates the water's temperature exiting a specially designed blending chamber.

## Specifications

- ◆ **Maximum water temperature:** ..... 200°F/93°C
- ◆ **Maximum working pressure:** ..... 150 psi
- ◆ Standard: stainless steel  
Available: M-159, bronze
- ◆ Simple visual recognition of valve position
- ◆ Easy to maintain and replace globe valves
- ◆ Flow rates adjustable from low to high
- ◆ Less wrist fatigue in turning valves to On/Off position

**NOTE:** Not suitable for steam service

*Please see reverse side for parts listing.*



**Shown:** Stainless steel **M-750TG** with globe valves;  
shown with premium hose assembly and **S-70 Series** nozzle  
**Available:** Standard **M-750**, bronze **M-159** and **M-159TG**



## USA Headquarters

2801 Baglyos Circle ♦ Bethlehem, PA 18020

Phone: (484) 893-5080 ♦ Fax: (484) 893-5099 ♦ Toll Free: (877) STRAHMAN

[www.strahmanvalves.com](http://www.strahmanvalves.com)

## France

Savoie Hexapole, F-73420 Mery, France

Tel: 33 (0) 4 79 35 78 00

Fax: 33 (0) 4 79 35 78 20

## Germany

Zum Schwarzhof 14, 77704, Oberkirch, Germany

Tel: 49 (0) 7802 - 7037879

Fax: 49 (0) 7802 - 7037889

# M-750TG Mixing Units-Hose Stations

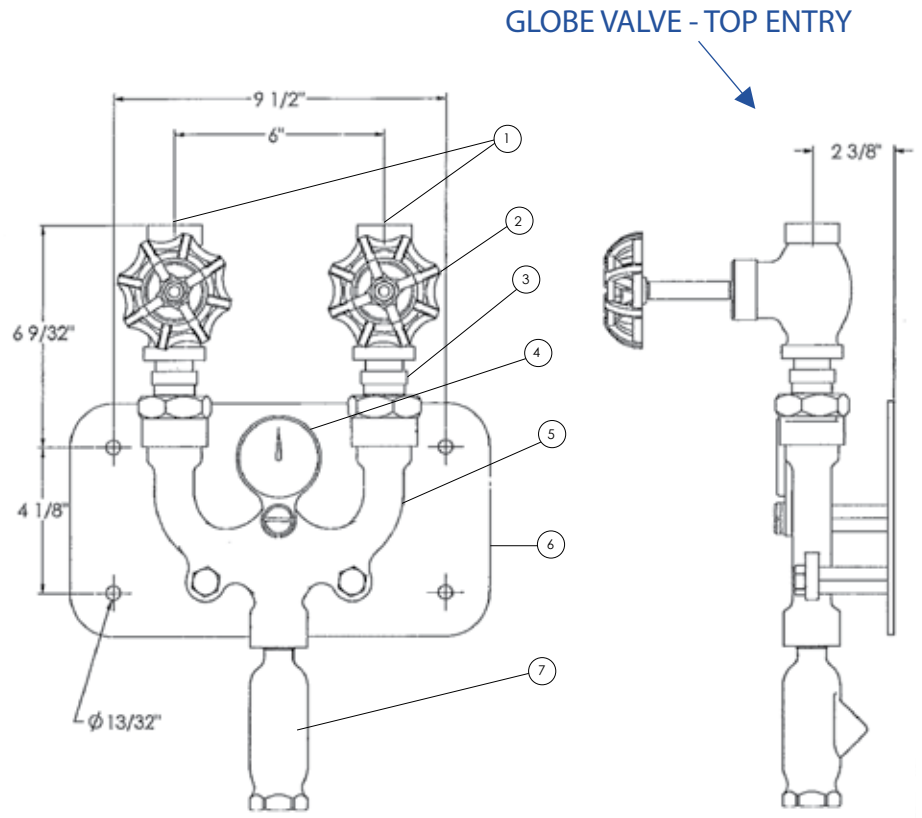
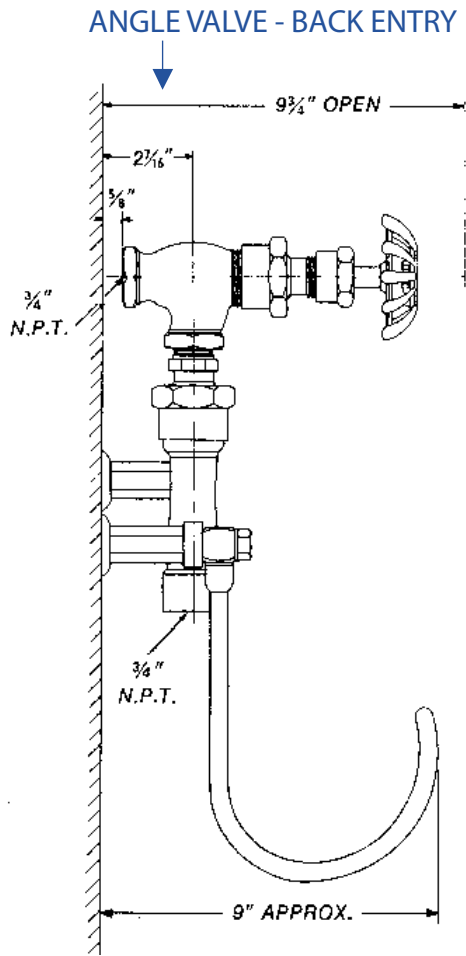

PARTS	
PART NO.	PART
1	3/4" NPT FEMALE INLET
2	CONTROL VALVE
3	BALL CHECK VALVE
4	TEMPERATURE GAUGE
5	M-750 MIXING UNIT
6	WALL MOUNTING PLATE
7	BELNDING CHAMBER