



GAUGES
THERMOMETERS
TRANSMITTERS
RECORDERS
CONTROLLERS
LIQUID LEVEL SYSTEMS
RTDS

MICROBASED 1/4 DIN SINGLE LOOP PROFILE CONTROLLER

AIC 600

Installation, Wiring, Operation Manual



Would you like information on our other products?

**Make a copy of this page, check next to the products you
are interested in and fax it to us at 1-518-922-8997 or
just call us at 1-800-833-0081**

Gauges
 Thermometers
 Transmitters
 RTDs

Recorders
 Controllers
 Liquid Level Systems

Your Name

Company Name

Street Address

City, State, Zip/ Postal Code, Country, and Telephone Number

Table of Contents

SECTION 1 - GENERAL		Page Number
1.1	Product Description	5
 SECTION 2 - INSTALLATION & WIRING		
2.1	Installation & Wiring	7
2.2	Unpacking	7
2.3	Location	7
2.4	Mounting	7
2.5	Preparation for Wiring	8
2.6	Wiring Connections	13
 SECTION 3 - CONFIGURATION		
3.1	Configuration	21
3.2	Shipped Configuration/Jumper Positioning	22
3.3	Start up Procedure	22
3.4	Front Panel Operation	23
3.5	Operation Summary	25
 SECTION 4 - OPERATION		
4.1	Operation	38
4.2	Alarm Operation	44
4.3	Tune Mode Operation	44
 SECTION 5 - SERVICE		
5.1	Service	47
5.2	Calibration	47
5.3	Test Mode Procedures	52
5.4	Troubleshooting and Diagnostics	56
 APPENDICES		
A -	Board Layouts	
	A-1 Power Supply Board	63
	A-2 Processor Board	64
	A-3 Option Board (Revision D and Below)	65
	Option Board (Revision E and Above)	66
B -	Glossary	67
C -	Order Matrix	70
D -	Specifications	71
E -	Software Record/Reference Sheet	75
F -	Profile Development Sheet	78
	Warranty	Inside Back Cover

Figures and Tables

Figure 1-1	Front Panel Display	5
Figure 2-1	Installation View and Dimensions	8
Figure 2-2	Noise Suppression	10
Figure 2-3	Noise Suppression	10
Figure 2-4	Wiring Connection Diagram	13
Figure 2-5	AC Power Input	14
Figure 2-6	Thermocouple Input	14
Figure 2-7	RTD Input	15
Figure 2-8	Volt, Millivolt, milliamp Input	15
Figure 2-9A	24V Transmitter Power Supply	16
Figure 2-9B	24V Power Supply	16
Figure 2-10	Remote Run/Hold Input	17
Figure 2-11	Remote Digital Communications Option	17
Figure 2-12	Alternate Remote Digital Communications	18
Figure 2-13	Relay Output	18
Figure 2-14	SSR Driver Output	19
Figure 2-15	Current Output	20
Figure 2-16	Position Proportioning Control	20
Figure 4-1	Dual Output Control	42
Table 3-1	Program Mode Configuration Procedures	25
Table 3-2	Tune Mode Configuration Procedures	32
Table 3-3	Profile Entry Mode Configuration Procedures	35
Table 3-4	Enable Mode Configuration Procedures	36
Table 4-1	Profile Continue Mode	40
Table 5-1	Calibration Procedures	48
Table 5-2	Test Procedures and Description	53

Flow Charts

Flow - Calibration	47
Flow - Enable Mode	37
Flow - Profile Entry	34
Flow - Profile Continue	39
Flow - Program Mode	26
Flow - Tune Mode	33
Flow - Test	52

Product Description 1.1

1.1.1 GENERAL

This instrument is a microprocessor based profiling controller capable of measuring, displaying, and controlling a process variable from a variety of inputs. Applications include temperature, pressure, level, flow, and others.

Control functions, alarm settings and other parameters are easily entered via the front keypad. All user data can be protected from unauthorized changes by the Enable mode security system, and is protected against loss from AC power failure by battery back-up.

The process input is user configurable to directly connect to either thermocouple, RTD, mVDC, VDC, or mADC inputs, depending on the input type specified. Thermocouple and RTD linearization, as well as thermocouple cold junction compensation, is performed automatically. The instrument's process input is isolated from the rest of the instrument.

The instrument can be ordered to operate on either 115VAC or 230VAC power at 50/60Hz. The instrument is housed in an extruded aluminum enclosure suitable for panel mounting.

FIGURE 1-1

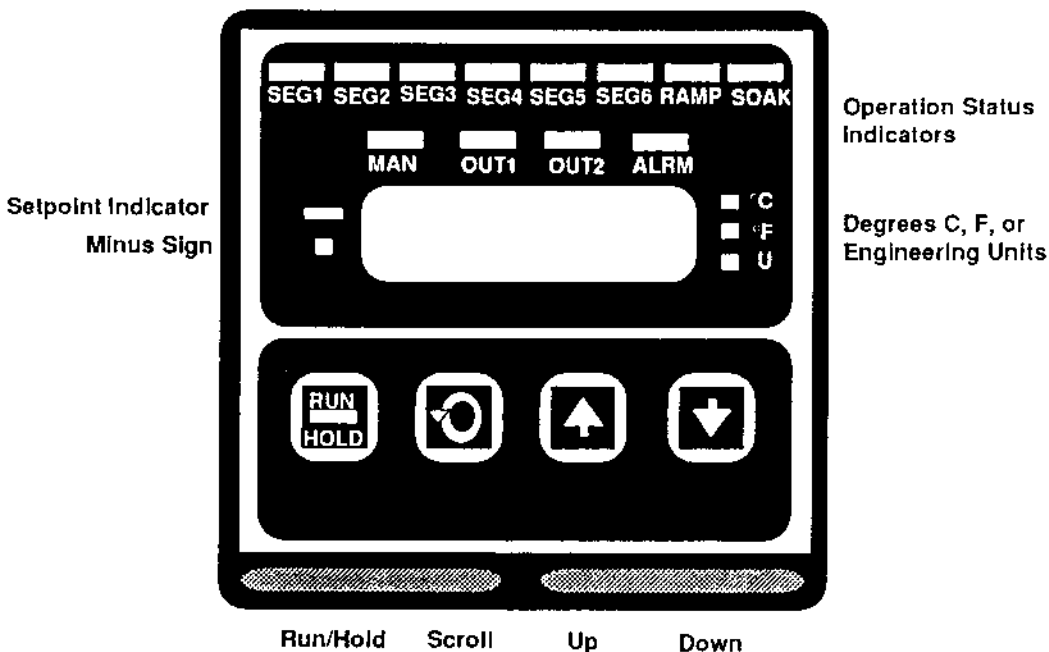

1.1.2 DISPLAYS

Each instrument is provided with a digital display and status indicators as shown in Figure 1-1. The digital display is programmable to display the process value only, process and setpoint, deviation from setpoint only, deviation and setpoint, or setpoint continuously.

Status indication is provided for Alarm, Output 1, Output 2, degree C, degree F, engineering units, Manual operation, Segment 1 thru 6, Ramp, and Soak.

Display resolution is programmable for 0.1 or 1 degree for thermocouple and RTD inputs, and 0.001, 0.01, 0.1, or 1 unit for volt, mV input types.

1.1.3 CONTROL

Instruments can be programmed for On-Off, Time Proportioning, Current Proportioning, or Position Proportioning control implementations. Selectable direct or reverse control action is also provided. Proportional control implementations are provided with fully programmable PID parameters.

Automatic to Manual switching is easily accomplished via the Standby mode. Switching is bumpless, and while in manual, manipulation of proportional outputs is possible.

Other standard control features include control output limits, setpoint limits, anti-reset windup control, and a unique Automatic Transfer function, which, if configured, allows manual control of the process until setpoint is reached, at which time the unit will automatically transfer from manual to automatic control.

Remote Run-Hold capability can be provided via the Auxiliary Input.

1.1.4 PROGRAMMABLE SETPOINT PROFILES

Up to eight profiles can be programmed on any of these Profile Controllers. Each of the eight profiles can contain up to six segments. Each segment contains a ramp and a soak operation. Profiles can be programmed to run continuously or any number of times up to 9999. A combination of profiles may be combined for back to back execution. This has the affect of acting as a single profile of more than six segments.

Assured Soak is provided with the use of two programmable parameters that will activate an Auto/Hold feature. This feature will place a running profile in the Hold condition and prohibit a Soak operation from starting or completing if an acceptable process value is not reached and then maintained.

Event outputs may also be provided. Up to three events may be assigned and can be turned on or off at the beginning of each ramp and soak.

1.1.5 ALARMS

Alarm settings are fully programmable. Alarm type may be set as Process direct or reverse (High or Low), Deviation direct or reverse (above or below setpoint), or Deviation Band type (closed or open within band).

Alarm outputs can be provided by assigning any specified relays (SPST or SSR driver) to the respective alarm.

1.1.6 DIGITAL COMMUNICATIONS

The instrument can be provided with an RS-422/485 communications port which allows bi-directional multidrop communications with a supervisory computer.

Installation and Wiring 2.1

Read these instructions carefully before proceeding with installation and operation. Electrical code requirements and safety standards should be observed. Installation should be performed by qualified personnel.

CAUTION: The instrument AC power input is specified in the model number and on the wiring label for either 115VAC or 230VAC. Verify the AC power input required by the instrument prior to proceeding with installation.

Unpacking 2.2

Remove the instrument from the carton and inspect it for any damage due to shipment. If any damage is noticed due to transit, report and file a claim with the carrier. Write the model number and serial number of the instrument on the front cover of this Operation Manual for future reference when corresponding with the factory.

Location 2.3

Locate the instrument away from excessive moisture, oil, dust, and vibration. Do not subject the instrument to operating temperatures outside of 0 to 55° C (32° to 131° F).

Mounting 2.4

Figure 2-1 (page 8) shows installation view and physical dimensions for the panel mounted instrument.

The electronics can be removed from the housing for installation, if so desired. To remove, loosen the locking screw centered on the bottom face of the unit. The instrument pulls straight out. When installing, be sure that the vertically mounted circuit boards are inserted in the correct grooves in the top and bottom of the housing. Also make sure the screw lock is sufficiently tight. When installing multiple instruments, be sure to reinsert the proper instrument into its correct enclosure by matching the serial number with the number inside the housing. This will insure that the accuracy of the control will be within the published specifications. The ambient compensator on the rear of the enclosure is calibrated to the electronics at the factory.

Cut the panel cutout to the dimensions shown in Figure 2-1 (page 8). Insert the instrument housing into the panel cutout and install the mounting bracket. Place the mounting screws on the back of the housing and tighten until the instrument is rigidly mounted. Do not overtighten.

A surface mounting kit is available - part number 64405801. For installation of the instrument in areas subjected to washdowns, a water tight cover option is available (part # 64417801).

FIGURE 2-1

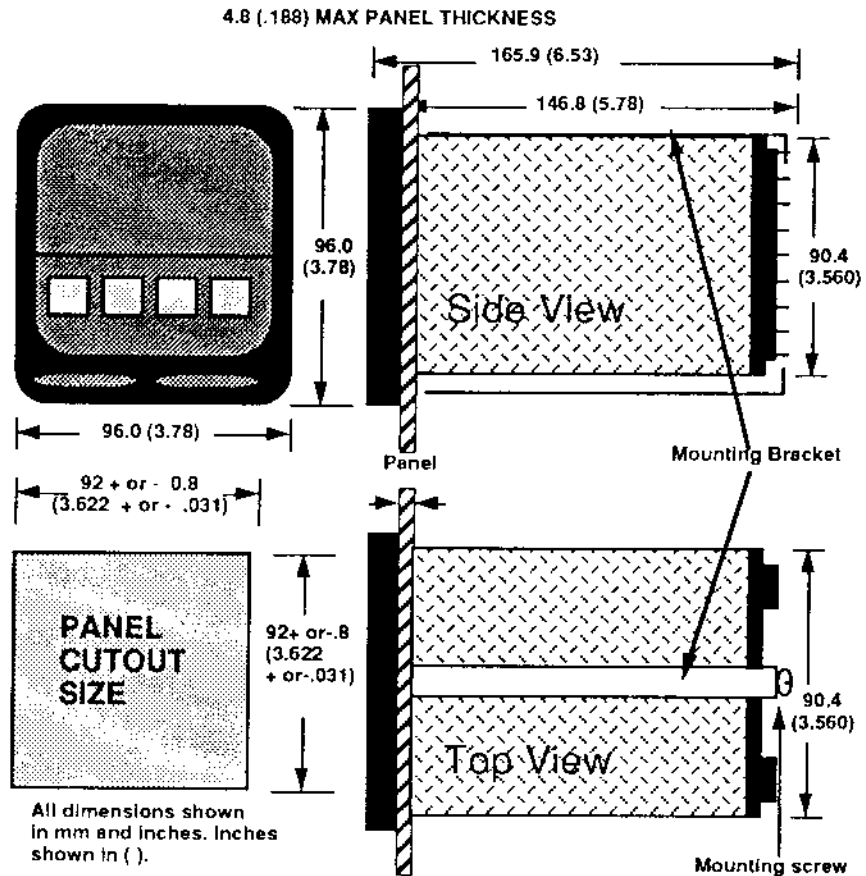

Preparation for Wiring 2.5

2.5.1 WIRING GUIDELINES

Electrical noise is a phenomenon typical of industrial environments. The following are guidelines that must be followed to minimize the effect of noise upon any instrumentation.

2.5.1.1 INSTALLATION CONSIDERATIONS

Listed below are some of the common sources of electrical noise in the industrial environment:

- Ignition Transformers
- Arc Welders
- Mechanical contact relay(s)
- Solenoids

Before using any instrument near the devices listed, the instructions below should be followed:

1. If the instrument is to be mounted in the same panel as any of the listed devices, separate them by the largest distance possible. For maximum electrical noise reduction, the noise generating devices should be mounted in a separate enclosure.

2. If possible, eliminate mechanical contact relay(s) and replace with solid state relays. If a mechanical relay being powered by an instrument output device cannot be replaced, a solid state relay can be used to isolate the instrument.
3. A separate isolation transformer to feed only instrumentation should be considered. The transformer can isolate the instrument from noise found on the AC power input.
4. If the instrument is being installed on existing equipment, the wiring in the area should be checked to insure that good wiring practices have been followed.

2.5.1.2 AC POWER WIRING

Earth Ground

The instrument includes noise suppression components that require an earth ground connection to function. To verify that a good earth ground is being attached, make a resistance check from the instrument chassis to the nearest metal water pipe or proven earth ground. This reading should not exceed 100 ohms.

Neutral (For 115VAC)

It is good practice to assure that the AC neutral is at or near ground potential. To verify this, a voltmeter check between neutral and ground should be done. On the AC range, the reading should not be more than 50 millivolts. If it is greater than this amount, the secondary of this AC transformer supplying the instrument should be checked by an electrician. A proper neutral will help ensure maximum performance from the instrument.

2.5.1.3 WIRE ISOLATION

Four voltage levels of input and output wiring may be used with the unit:

- * Analog input or output (i.e. thermocouple, RTD, VDC, mVDC or mADC)
- * SPST Relays
- * SSR driver outputs
- * AC power

The only wires that should be run together are those of the same category. If they need to be run parallel with any of the other lines, maintain a minimum 6 inch space between the wires. If wires must cross each other, do so at 90 degrees. This will minimize the contact with each other and reduces "cross talk". *"Cross talk" is due to the EMF (Electro Magnetic Flux) emitted by a wire as current passes through it. This EMF can be picked up by other wires running in the same bundle or conduit.*

In applications where a High Voltage Transformer is used, (i.e. ignition systems) the secondary of the transformer should be isolated from all other cables.

This instrument has been designed to operate in noisy environments, however, in some cases even with proper wiring it may be necessary to suppress the noise at its source.

2.5.1.4 USE OF SHIELDED CABLE

Shielded cable helps eliminate electrical noise being induced on the wires. All analog signals should be run with shielded cable. Connection lead length should be kept as short as possible, keeping the wires protected by the shielding. The shield should be grounded at one end only. The preferred grounding location is at the sensor, transmitter or transducer.

2.5.1.5 NOISE SUPPRESSION AT THE SOURCE

Usually when good wiring practices are followed, no further noise protection is necessary. Sometimes in severe electrical environments, the amount of noise is so great that it has to be suppressed at the source. Many manufacturers of relays, contactors, etc. supply "surge suppressors" which mount on the noise source.

For those devices that do not have surge suppressors supplied, RC (resistance-capacitance) networks and/or MOV (metal oxide varistors) may be added.

Inductive Coils - MOV's are recommended for transient suppression in inductive coils connected in parallel and as close as possible to the coil. See Figure 2-2. Additional protection may be provided by adding an RC network across the MOV.

Contacts - Arcing may occur across contacts when the contact opens and closes. This results in electrical noise as well as damage to the contacts. Connecting a RC network properly sized can eliminate this arc.

For circuits up to 3 amps, a combination of a 47 ohm resistor and 0.1 microfarad capacitor (1000 volts) is recommended. For circuits from 3 to 5 amps, connect 2 of these in parallel. See Figure 2-3.

FIGURE 2-2

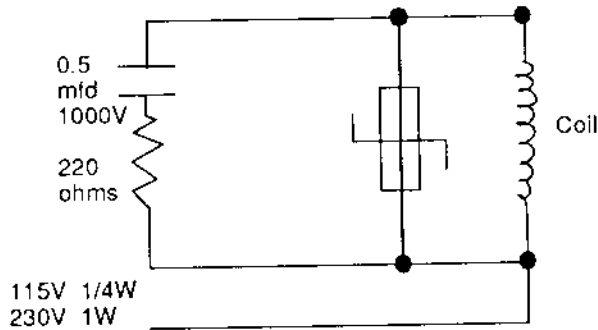
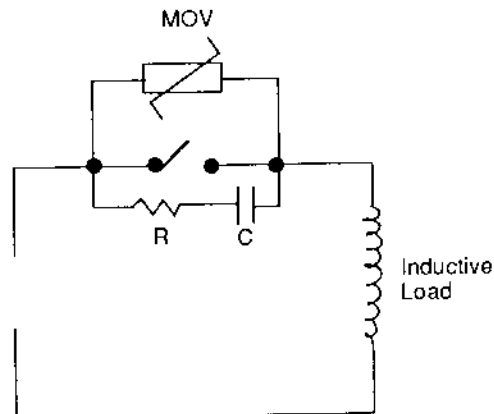

FIGURE 2-3



2.5.2 SENSOR PLACEMENT (Thermocouple or RTD)

If the temperature probe is to be subjected to corrosive or abrasive conditions, it should be protected by the appropriate thermowell. The probe should be positioned to reflect true process temperature:

- In liquid media - the most agitated area.
- In air - the best circulated area.

THERMOCOUPLE LEAD RESISTANCE

Thermocouple lead length can affect instrument accuracy since the size (gauge) and the length of the wire affect lead resistance.

To determine the temperature error resulting from the lead length resistance, use the following equation:

$T_{err} = TLe \cdot L$ where; TLe = value from appropriate table below
 L = length of leadwire in thousands of feet

TABLE 1

Temperature error in °C per 1000 feet of Leadwire									
AWG No.	Thermocouple Type:								
	J	K	T	R	S	E	B	N	C
10	.34	.85	.38	1.02	1.06	.58	7.00	1.47	1.26
12	.54	1.34	.61	1.65	1.65	.91	11.00	2.34	2.03
14	.87	2.15	.97	2.67	2.65	1.46	17.50	3.72	3.19
16	1.37	3.38	1.54	4.15	4.18	2.30	27.75	5.91	5.05
18	2.22	5.50	2.50	6.76	6.82	3.73	44.25	9.40	8.13
20	3.57	8.62	3.92	10.80	10.88	5.89	70.50	14.94	12.91
24	8.78	21.91	9.91	27.16	27.29	14.83	178.25	37.80	32.64

TABLE 2

Temperature Error in °F per 1000 feet of Leadwire									
AWG No.	Thermocouple Type:								
	J	K	T	R	S	E	B	N	C
10	.61	1.54	.69	1.84	1.91	1.04	12.60	2.65	2.27
12	.97	2.41	1.09	2.97	2.96	1.64	19.80	4.21	3.66
14	1.57	3.86	1.75	4.81	4.76	2.63	31.50	6.69	5.74
16	2.47	6.09	2.77	7.47	7.52	4.14	49.95	10.64	9.10
18	4.00	9.90	4.50	12.17	12.28	6.72	79.95	10.64	9.10
20	6.43	15.51	7.06	19.43	19.59	10.61	126.90	26.89	23.24
24	15.80	39.44	17.83	48.89	49.13	26.70	320.85	68.03	58.75

Example:

An MIC is to be located in a control room 660 feet away from the process. Using 16 AWG, type J thermocouple, how much error is induced?

$T_{err} = TLe \cdot L$
 $TLe = 2.47$ (°F/1000 ft) from Table 2

$T_{err} = 2.47$ (°F/1000 ft) * 660 ft

$T_{err} = 1.6$ °F

RTD LEAD RESISTANCE

RTD lead length can affect instrument accuracy, since the size (gauge) and length of the wire affect lead resistance.

To determine the temperature error resulting from the lead length resistance, use the following equation:

$$T_{err} = TLe \cdot L \quad \text{where; } TLe = \text{value from Table 3 if 3 wire RTD or Table 4 if 2 wire RTD}$$

$L = \text{length of lead wire in thousands of feet}$

TABLE 3 - 3 Wire RTD

AWG No.	Error °C	Error °F
10	+/- 0.04	+/- 0.07
12	+/- 0.07	+/- 0.11
14	+/- 0.10	+/- 0.18
16	+/- 0.16	+/- 0.29
18	+/- 0.26	+/- 0.46
20	+/- 0.41	+/- 0.73
24	+/- 0.65	+/- 1.17

TABLE 4 - 2 Wire RTD

AWG No.	Error °C	Error °F
10	+/- 5.32	+/- 9.31
12	+/- 9.31	+/- 14.6
14	+/- 13.3	+/- 23.9
16	+/- 21.3	+/- 38.6
18	+/- 34.6	+/- 61.2
20	+/- 54.5	+/- 97.1
24	+/- 86.5	+/- 155.6

Example:

An application uses 2000 feet of 18 AWG copper lead wire for a 3 wire RTD sensor. What is the worst case error due to this leadwire length?

$$T_{err} = TLe \cdot L$$

$TLe = +/- .46 \text{ (°F/1000 ft) from Table 3}$

$$T_{err} = +/- .46 \text{ (°F/1000 ft)} \cdot 2000 \text{ ft}$$

$$T_{err} = +/- 0.92\text{°F}$$

Wiring Connections 2.6

All wiring connections are typically made to the instrument with it installed. Terminal connections should be made via the rear panel with 14 gauge wire maximum (see Figure 2-4).

FIGURE 2-4

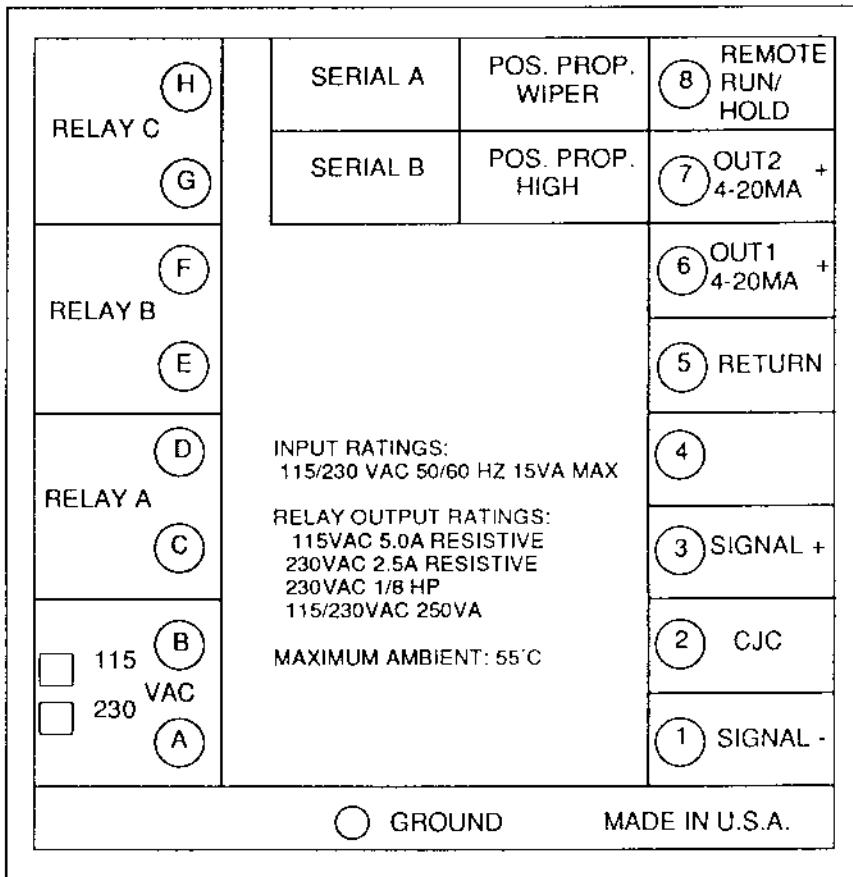

2.6.1 INPUT CONNECTIONS

WARNING: Avoid electrical shock. AC power wiring must not be connected at the source distribution panel until all wiring connections are completed.

Consult the model code and the wiring label for the appropriate line voltage for the instrument.

FIGURE 2-5

AC Power

Connect 115 VAC hot and neutral to terminals B and A respectively as illustrated below. Connect 230 VAC as described below. Connect Earth ground to the ground screw as shown.

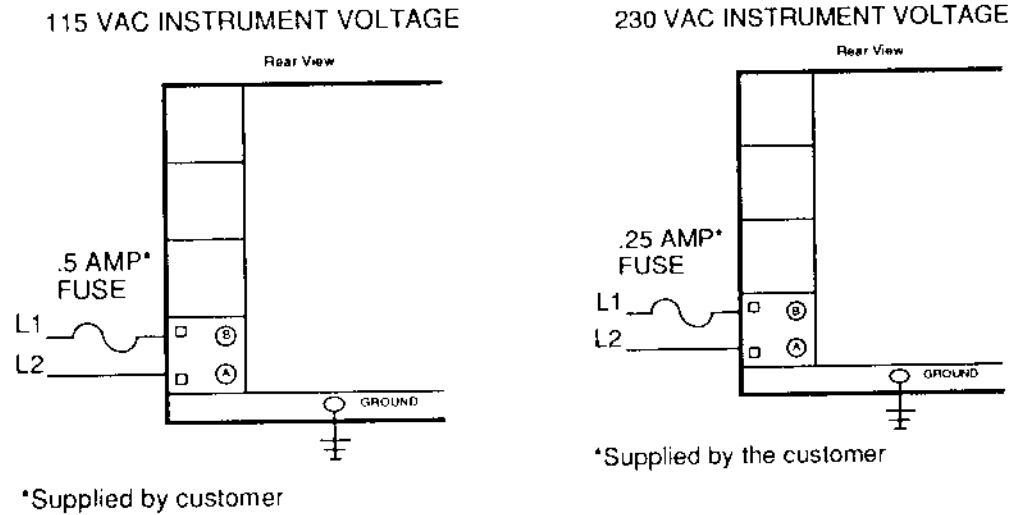

FIGURE 2-6

Thermocouple Input

Make thermocouple connections as illustrated below. Connect the positive lead of the thermocouple to terminal 3, and the negative to terminal 1. For industrial environments with comparatively high electrical noise levels, shielded thermocouples and extension wire are recommended. Be sure that the input conditioning jumpers are properly positioned for a thermocouple input. See Appendix A-2 (page 64) and A-3 (page 65 or 66).

THERMOCOUPLE INPUT

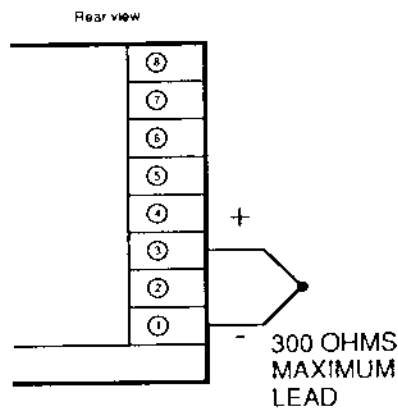

FIGURE 2-7

RTD Input

Connections are shown for 3 wire and 2 wire RTD's. If a three wire device is used, install the common wires to terminals 1 and 5. If a two wire device is used, install a jumper between terminals 1 and 5.

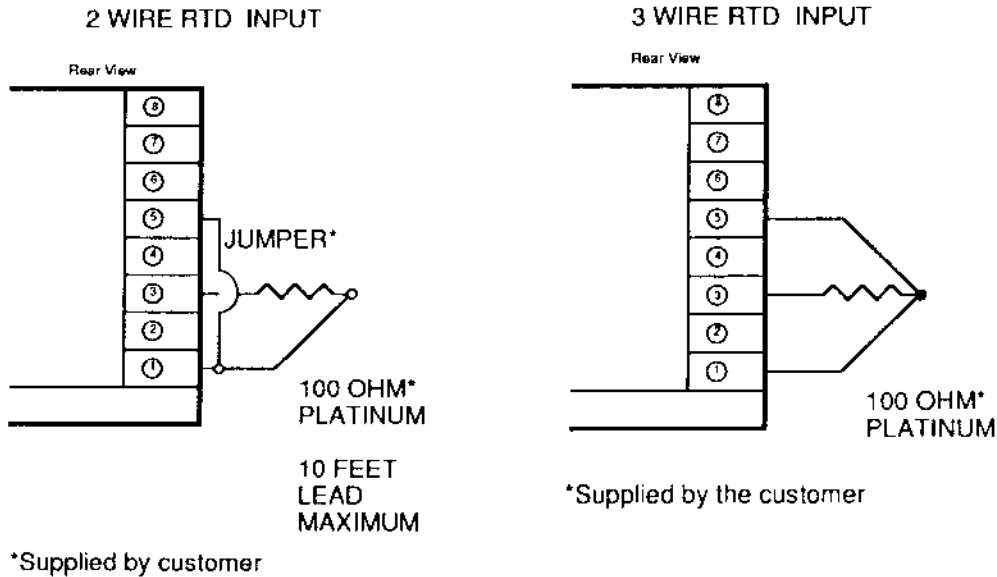
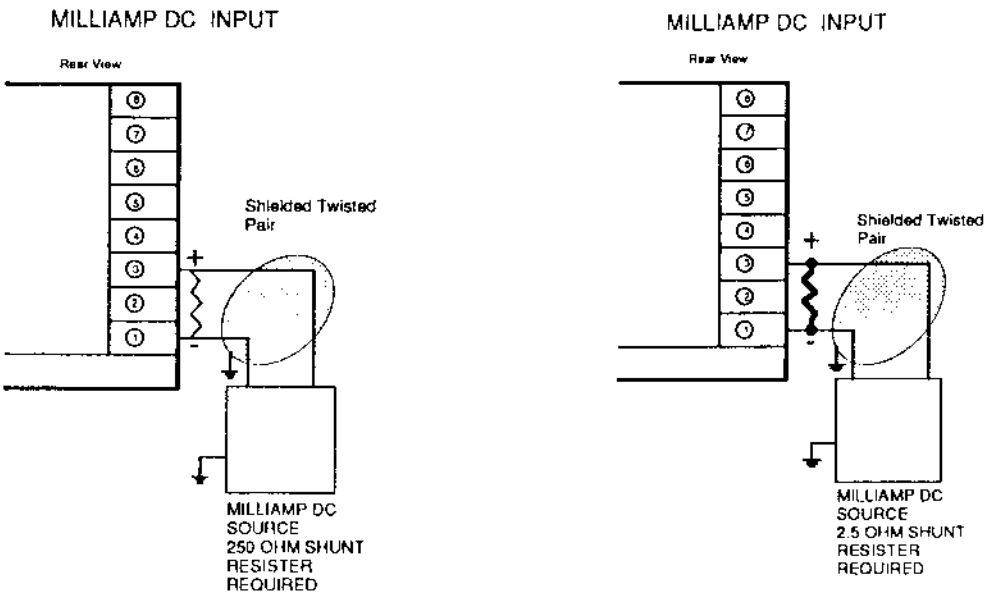

FIGURE 2-8

Volt, Millivolt and Milliamp Input

Make volt, millivolt or milliamp connections as shown below. Terminal 3 is positive and terminal 1 is negative. Milliamp input requires a shunt resistor be installed across the input terminals as shown. 4-20mA input are accommodated by setting up the instrument for either 10 to 50mVDC or 1 to 5VDC input. Make sure that the appropriate resistor value is used. Terminal 3 is positive and terminal 1 is negative. (.1% resistors recommended.) (Continued on next page)



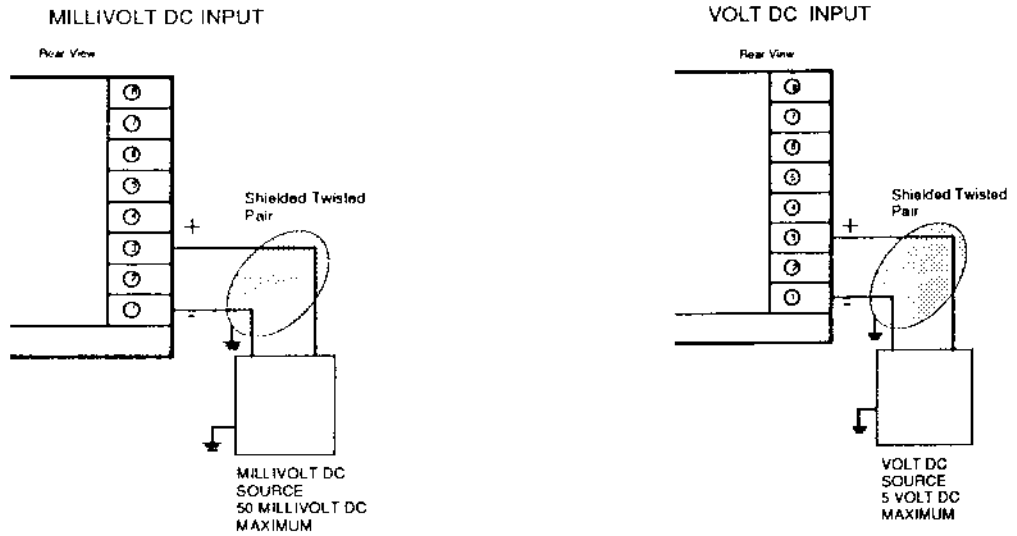

FIGURE 2-9A

24Volt Transmitter Power Supply (XP Option)

Make connections as shown below. Terminal 3 is positive (+) and terminal 1 is negative (-). Be sure the input conditioning jumpers are properly positioned for the input type selected. See Figure A-2 Processor Board, page 64 and Figure A-3 Option Board, page 65 or 66. Note the 250 ohm shunt resistor is not required.

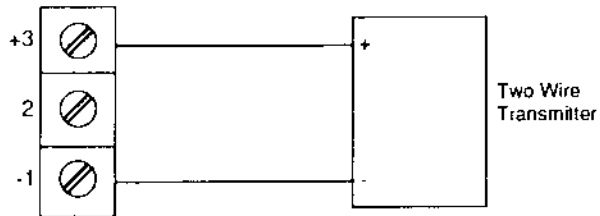

FIGURE 2-9B

24 Volt Power Supply (XA Option)

Make connections as shown below. Terminal G is positive (+) and terminal H is negative (-). Be sure the input conditioning jumpers are properly positioned. See Figure A-2 Processor Board, page 64 and Figure A-3 Option Board, page 65 or 66.

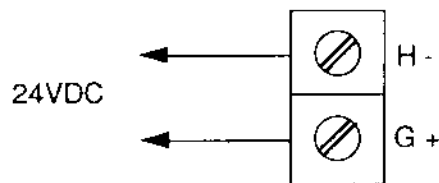

FIGURE 2-10

Remote Run/Hold Input

If Remote Run/Hold capability has been specified, make connections as shown. Terminal 5 is the ground and terminal 8 is the input.

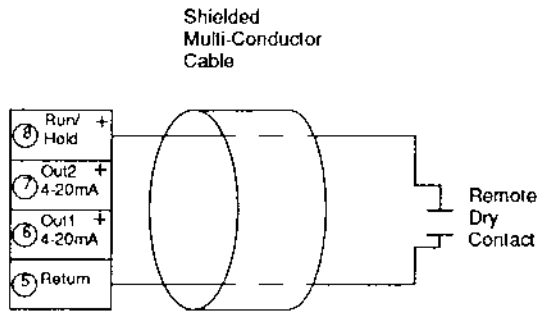

FIGURE 2-11

Remote Digital Communications RS-485 Terminals 7 & 8 (Optional)

If the communications network continues on to other units, connect the shields together, but not to the instrument. A terminating resistor should be installed at the terminals of the last instrument in the loop. The shield should be grounded at the computer or the convertor box, if used. See the Protocol Manual (Form 2878) for more details on the use of the digital communications option.

**DIGITAL COMMUNICATIONS
CONNECTIONS - TERMINALS 7 & 8**

Terminals 7 & 8 are used for communications when the model number is 6XXYX3X or 6XXYX5X where X= any valid number and Y=0, 1, or 2.

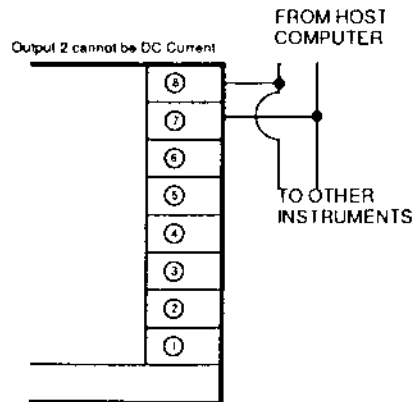

FIGURE 2-12

Alternate Remote Digital Communications RS-485 Terminals G & H (Optional)

If the communications network continues on to other units, connect the shields together, but not to the instrument. A terminating resistor should be installed at the terminals of the last instrument in the loop. The shield should be grounded at the computer or the converter box, if used. See the Protocol Manual (Form 2878) for more details on the use of the digital communications option.

Terminals G & H are used for communications when the model number is 6XXY04X or 6XXY06X where X= any valid number and Y=3, 4, or 5.

DIGITAL COMMUNICATIONS CONNECTIONS - TERMINALS G & H

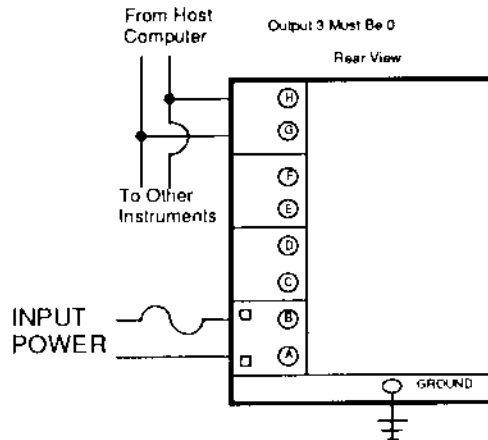

2.6.3 OUTPUT CONNECTIONS

Output connections include SPST relays, SSR drivers, and 4 to 20mA DC. Relay outputs may be assigned control, alarm or event functions. Assignment of output function is accomplished via the front keypad and is described in Section 4 (page 38) of this manual.

FIGURE 2-13

Relay Output

Connections are made to relay A as illustrated below. Connect relay(s) B & C (if present) in the same manner. Relay contacts are rated at 5 amp resistive at 130 VAC.

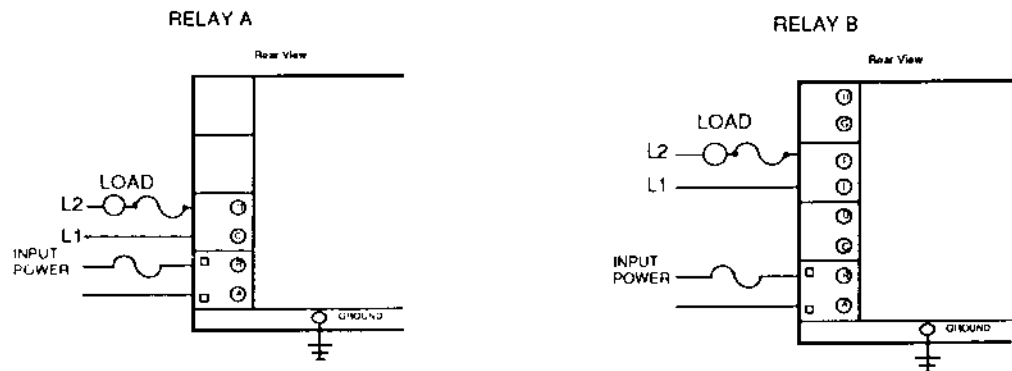

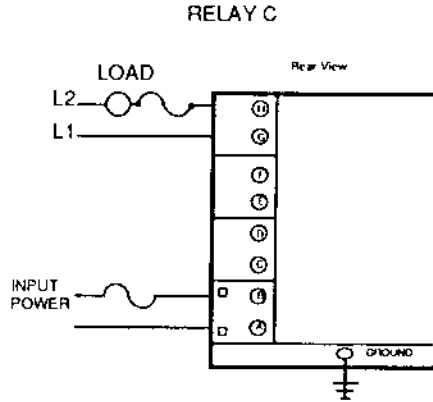
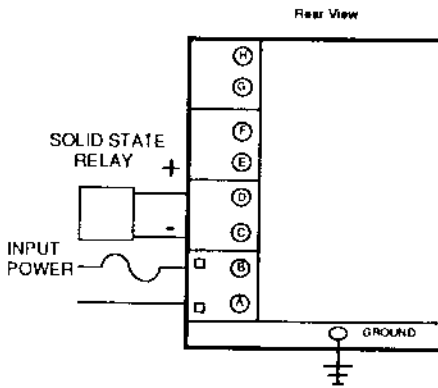

FIGURE 2-14

SSR Driver Output

Connections are made to the solid state relay driver output located in the Relay A position as shown. The solid state relay driver is a 5 VDC current sink output type. Connect the solid state relay driver(s) in the Relay B and C position (if present) in the same manner.

SSR DRIVER (RELAY A)



SSR DRIVER (RELAY B)

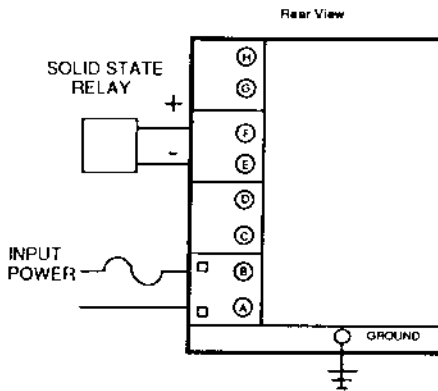

SSR DRIVER (RELAY C)

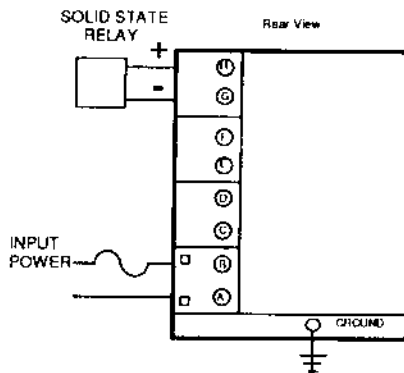
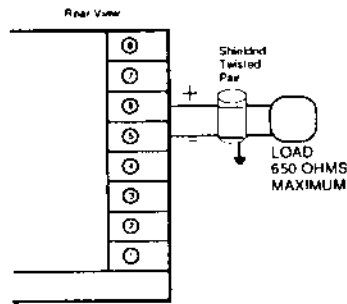

FIGURE 2-15

mADC Output

Connections are made to current outputs 1 and 2 as shown. Connect the positive lead to terminal 6 for Output 1 or terminal 7 for Output 2, the negative leads connect to terminal 5. Current outputs will operate up to 650 ohms maximum load. The current output(s) can be selected for either 4-20mADC or 0-20mADC (if EO option is present).

DC CURRENT OUTPUT 1



DC CURRENT OUTPUT 2

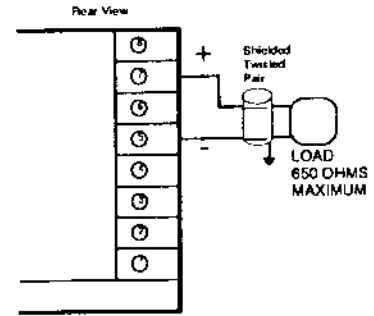
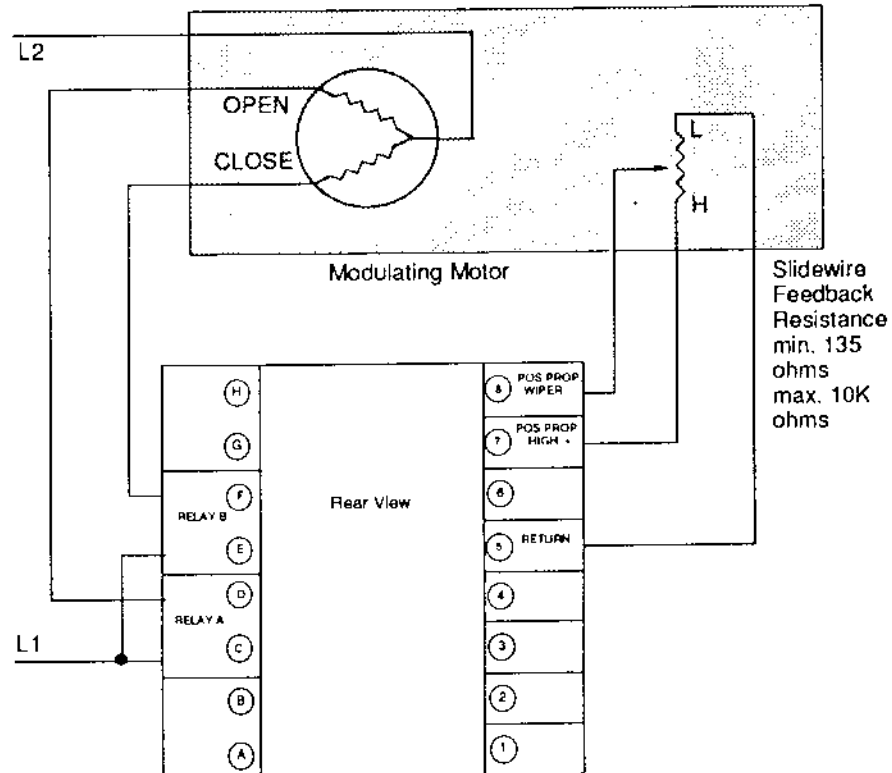

FIGURE 2-16

Position Proportioning Control

The relay and slidewire feedback connections are made as illustrated below. The relay assigned to Output 1 will be used to drive the motor in the open direction and the relay assigned to Output 2 will be used to drive the motor in the closed direction. The minimum slidewire feedback resistance is 135 ohms, the maximum resistance is 10K ohms.



Configuration 3.1

After completing installation of the unit, the configuration procedures contained within this section must be performed to prepare the instrument for operation on the intended application. The procedures include selecting specific parameters, entering data and possible jumper positioning.

Parameter selections and data entry are made via the front keypad. To ease configuration and operation, user entered data has been divided up into several modes. Each mode contains a different type of data or may be used for specific operating functions. These modes are as follows:

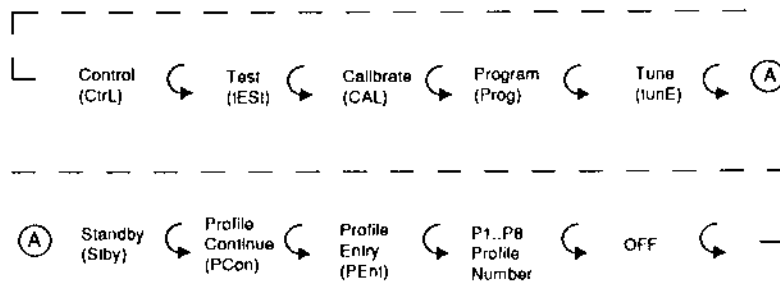

Mode	Display Code	Function	Description
Off	oFF	Operation	Outputs and Alarm Off
Control	Ctrl	Operation	Operates in automatic control; Change local setpoint, Alarms are On
Manual	Stby	Operation	Manual control of proportional outputs
Program	Prog	Configuration	Configures operating parameters
Tune	tunE	Configuration & Operation	Sets alarm settings & tunes the controller to the process
Profile Continue	PCon	Operation	Provides Profile Continue function
Profile Entry	PEnt	Configuration	Configures profile Entry parameters
P1 thru P8	P1 - P8	Operation	Executes any of the 8 profiles
Test	tEst	Service	Performs instrument tests
Calibration	CAL	Service	Performs instrument calibration
Enable	EnAb	Configuration	Locks out or enables access to any modes

(Continued on next page)

Associated with each mode is a series of unique displays which are accessed via the front keypad.

Prior to first time operation of the instrument, the configuration procedures for the Program, Profile Entry and Tune modes must be performed as applicable. The Control, Off, Standby, Profile Continue and Profile execution (P1 thru P8) modes are discussed in Section 4.1 (page 38) of this manual.

Calibration and Test modes are not used as part of instrument configuration or operation. These are used for service and maintenance functions and are discussed in Section 5.2 (page 47) of this manual.

Shipped Configuration/ Jumper Positioning 3.2

All configuration parameters in each mode are set to default values. These defaults are shown in tabular form under the description for each mode. Instrument AC power input is as specified in the instrument model number and as shown on the instrument ratings label.

3.2.1 JUMPER POSITIONING

Jumpers are used in all instruments to provide a security lockout feature and to condition the process input. All jumpers are typically of the three pin type and have two functions. All jumpers are either located on the Options Board or the Processor Board. Board layouts and jumper locations are shown in Appendix A-2 and A-3 (pages 64 and 65 or 66).

Check the actual jumper position in the instrument to be configured and verify the proper position for the intended application. If the current position is not correct, make changes.

Start up Procedures 3.3

Step by step procedures are provided in Tables 3-1 thru 3-4. These tables provide the display sequence, parameter adjustment and factory setting for each step.

The instrument is provided with a "time out" feature. If the instrument is in any mode and no keypad activity takes place for 30 seconds, the instrument will "time out" and exit the mode automatically. The instrument will display the code for the respective mode. If a mode code is displayed for 5 seconds with no activity it will then "time out" and proceed to either the Control or Off mode, depending upon which operational state the instrument was in last.

3.3.1 POWER UP PROCEDURE

- A. Verify that all electrical connections have been properly made before applying power to the instrument.

If the instrument is being configured for the first time, it may be desirable to disconnect the controller output connections as the instrument may go into the Control mode automatically following the power up sequence. Upon verification, power may be applied.

- B. Upon power up, "6XXX" will be displayed (X representing digits), then "XXX-", identifying the seven digit model number as defined in the order matrix. Next, the software revision level will be displayed in the format "rX.XX". Then "tSt1", "tSt2", and "tSt3" will be displayed while Test 1 thru 3 are executed automatically. Upon successful completion of these tests, "Ctrl" (for the Control mode) or "oFF" (for the Off mode) will be displayed for about three seconds. During this time the operator may select another mode prior to the instrument automatically going into the Control mode.
- C. If any error messages are displayed, refer to Section 5.4, page 56 for a definition of these error messages and the required action.
- D. If the instrument has been configured or operated previously, the mode that the instrument will go into upon power up, depends on what mode the instrument was in on power-down and how it has been programmed.

Front Panel Operation 3.4

3.4.1 DIGITAL DISPLAY AND STATUS LED's

The digital display provided has 4 digits and a decimal point. Each digit has seven segments and is capable of producing numeric characters from 0-9 and certain alpha characters. The digital display is used to provide indication of process variable as well as displaying codes used for configuration and operation of the instrument. The display includes the following Status Indicator LED's:

<u>Label</u>	<u>Color</u>	<u>Function</u>
MAN	Amber	Lights when the Manual StbY mode is on.
OUT1	Red	Lights when Output 1 is on.
OUT2	Amber	Lights when Output 2 is on.
ALRM	Red	Lights when either Alarm is on or active.
SEG 1 thru SEG 6	Red	Lights to indicate the profile section segment number that is active.
RAMP	Red	Lights during the Ramp section of any profile segment.
SOAK	Red	Lights during the Soak section of any profile segment.
SP	Green	Indicates that the value displayed is the setpoint.
C	Red	Lights to indicate that the process value is in terms of degrees C (Celcius)
F	Red	Lights to indicate that the process value is in terms of degrees F (Fahrenheit)
U	Red	Lights to indicate that the process value is in terms of engineering units.
-	Red	Lights to indicate a negative displayed value

3.4.2 KEYPAD CONTROLS

The keys on the keypad functions include:

- SCROLL:** Used to:
1. Display the enabled modes and programmed profiles.
 2. While in a mode, used to sequence the parameter codes and values.
 3. Exit some Test and Calibration functions.
 4. Work in conjunction with other keys:
 - a. With the UP key to display proportional output % when in the Control mode or while a profile is running.
 - b. With the DOWN key:
 - 1) On power up to alter model #
 - 2) Enter Cal/Test functions
 - 3) While a profile is running to view the ramp/soak time remaining.
- UP:** Used to:
1. Exit a mode.
 2. Turn a mode On in the Enable mode
 3. Increases a parameter numerical value.
 4. View the setpoint.
 5. Increase the setpoint value in the Control mode.
 6. Work in conjunction with the other keys:
 - a. With the SCROLL key to display proportional output %
 - b. With the DOWN key:
 - 1) On power up to reset the instrument
 - 2) Lamp test
 - 3) Enter the Enable mode
- DOWN:** Used for:
1. Enter a mode.
 2. Turn a mode Off in the Enable mode.
 3. Decrease a parameter numerical value.
 4. To start a profile when the profile number is displayed.
 5. Decrease the setpoint value in the Control mode.
 6. Step display through parameter codes in a mode.
 7. Work in conjunction with the other keys:
 - a. With the SCROLL key:
 - 1) On power up to alter the model number displayed.
 - 2) Enter Cal/Test functions
 - b. With the UP key:
 - 1) On power up resets the instrument
 - 2) Lamp test
 - 3) Enter the Enable mode
- RUN/HOLD:** Used to:
1. To start the profile number being displayed.
 2. Change between the profile Run and Hold profile conditions.

Operation Summary 3.5

The configuration and operating modes, the method of moving from one mode to another, and the basic parameter functions are described in each individual section. Data and parameter entry is made by stepping through each mode and making an appropriate response or entry to each step.

3.5.1 MODE SELECTION

If the instrument is in either the Off mode or Control mode, repeated depression of the Scroll key will cause the instrument to display the code corresponding to each mode which is enabled and each profile which has been entered. To enter a mode while its code is displayed, depress the Down key.

To exit the OFF mode, press the SCROLL key until Ctrl is displayed, then press the DOWN key.

Entry into any mode except the Control, Tune, Standby, Enable and Profile execution, will cause the instrument's outputs to turn off. Access to the Tune mode is provided while the instrument continues normal operation if in Control or running a Profile.

3.5.2 CONFIGURATION DISPLAYS

During configuration, the display is used to show the parameter codes and values. During normal operation, these displays are used to indicate process values, setpoints, etc. .

TABLE 3-1 PROGRAM MODE CONFIGURATION PROCEDURE

Press and release the SCROLL key until **Prog** is displayed. Press the DOWN key to enter the Program mode. Press the SCROLL key to advance the display through the parameter codes and their values. Use the Up and DOWN keys to adjust the values. After adjusting a parameter, press the SCROLL key to proceed to the next parameter. Each time the DOWN key is pressed while a parameter code is being displayed, such as dFF, the next parameter code in the sequence will be displayed.

After all selections have been made, to exit the mode, press the UP key with a parameter in the display (not a setting).

For illustration purposes, all available Program mode parameters have been listed. The parameters that will appear on the specific instrument will depend upon the model number (hardware configuration) of the instrument and on the parameter selections previously made.

For future reference, record the parameter selections for the application in the "Your Setting" column and on the Software Reference Sheet in Appendix E (page 75).

To prevent unauthorized changes to the Program mode, the mode can be disabled (turn off) in the Enable mode.

(Continued on next page)

PROGRAM MODE FLOW CHART

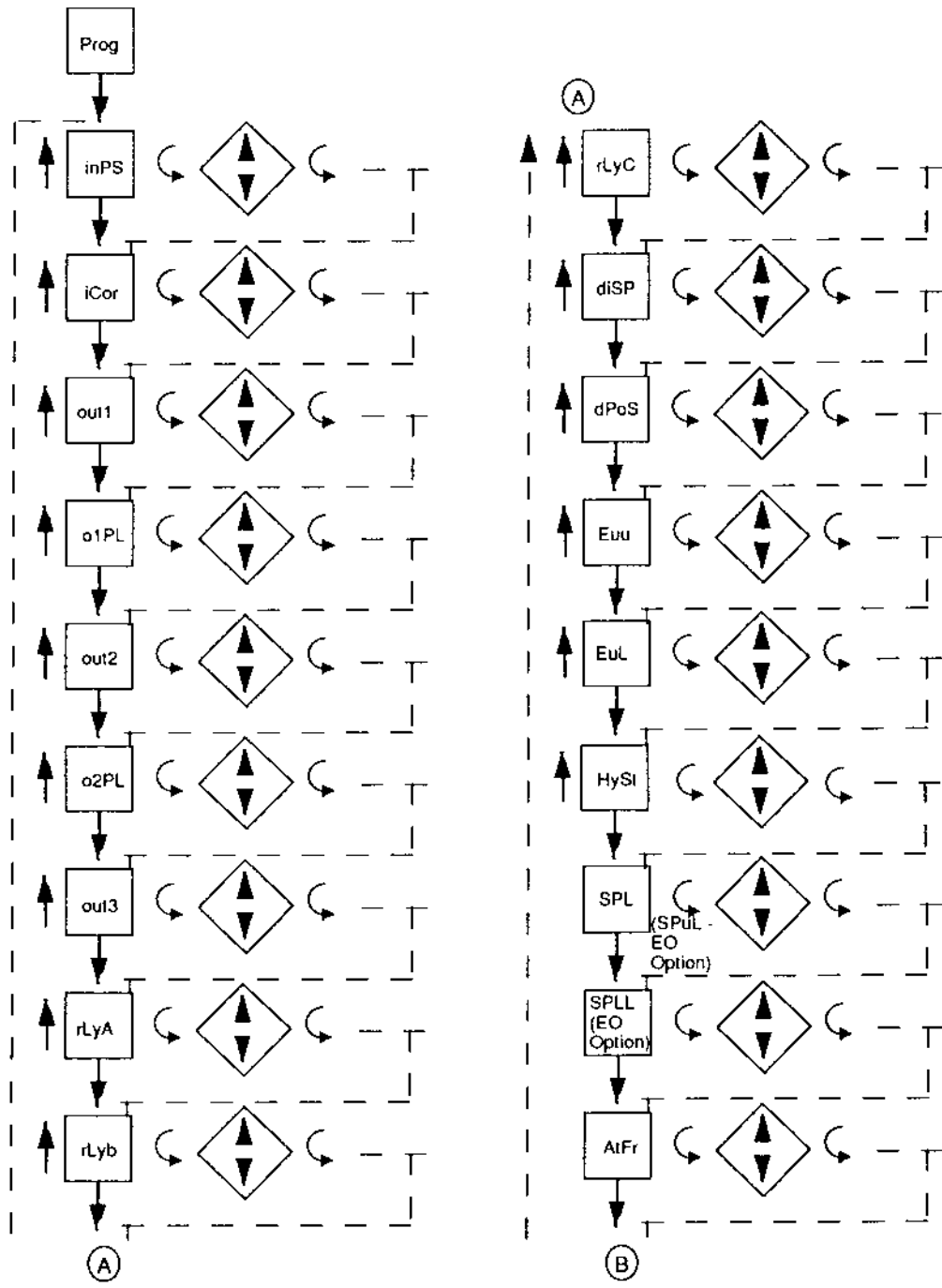

Key

	Actual Display
	On/Off Display - Use arrow keys to turn on or off
	Scroll Key
	Numeric Display - Use arrow keys to change value
	Up Arrow Key
	Down Arrow

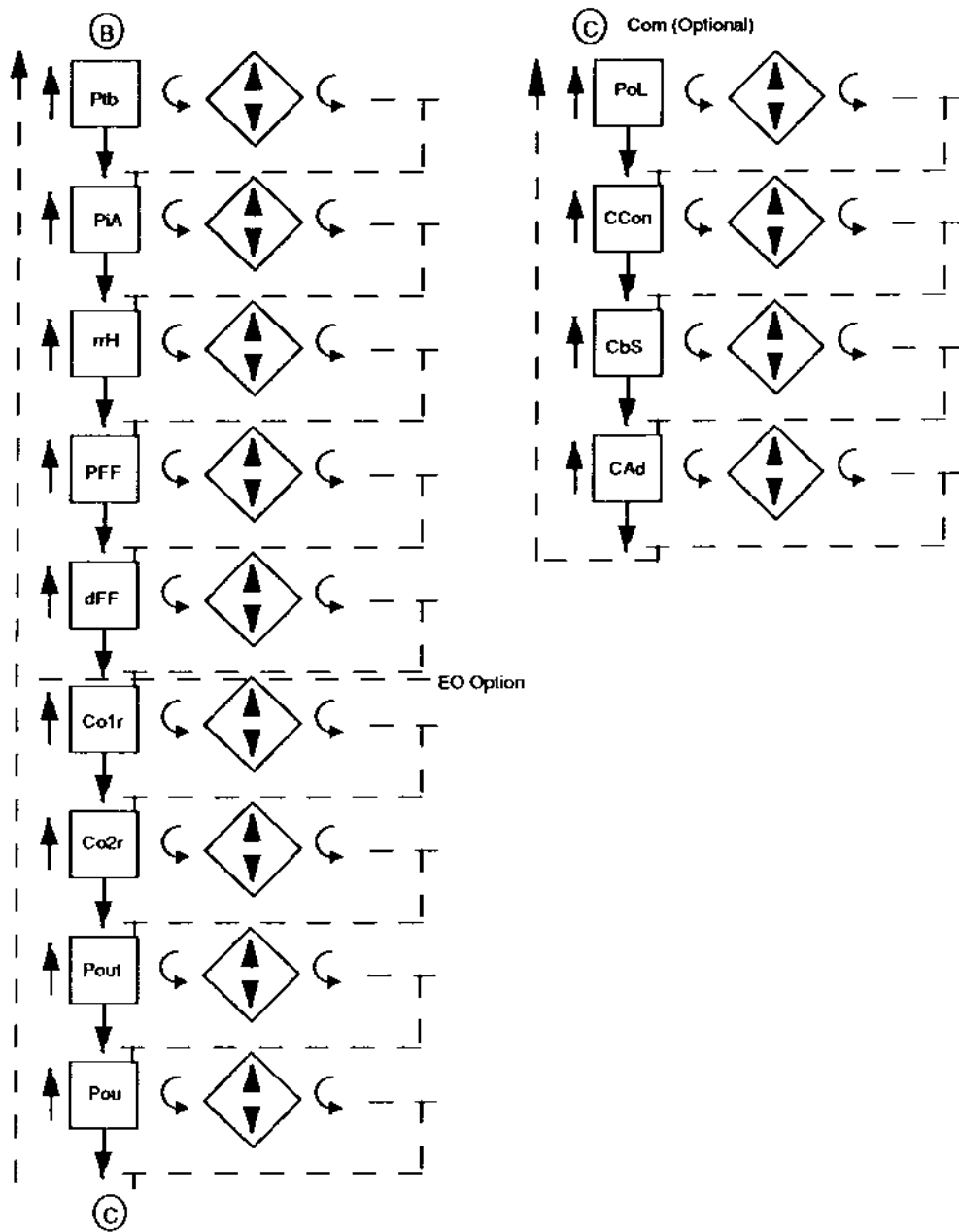

STEP	DESCRIPTION	DISPLAY CODE	AVAILABLE SETTINGS	FACTORY SETTING	YOUR SETTING
1	Input Selection	InPS	0=J T/C degrees C 1=J T/C degrees F 2=K T/C degrees C 3=K T/C degrees F 4=T T/C degrees C 5=T T/C degrees F 6=R T/C degrees C 7=R T/C degrees F 8=S T/C degrees C 9=S T/C degrees F 10=E T/C degrees C 11=E T/C degrees F 12=B T/C degrees C 13=B T/C degrees F 14=N T/C degrees C 15=N T/C degrees F 16=C T/C degrees C 17=C T/C degrees F 20=RTD degrees C 21=RTD degrees F 30=0 to 5VDC/0 to 20mA 31=1 to 5VDC/4 to 20mA 32=0 to 50mVDC 33=10 to 50mVDC 34=0 to 25mVDC	1	
2	Input Correction	ICor	-300 to 300 degrees	0	
3	Output 1	out1	1=On-Off - Direct (cooling) 2=On-Off - Reverse (heating) 3=Time Proportioning - Direct (cooling) 4=Time Proportioning - Reverse (heating) 5=Current Proportioning - Direct (cooling) 6=Current Proportioning - Reverse (heating) 7=Position Proportioning - Open	2	
4	Output 1 Percent Limit	o1PL	0 to 100%	100	
5	Output 2	out2	0=None (Position Prop. Direct - Close) 1=On-Off Direct (cooling) 2=On-Off - Reverse (heating) 3=Time Proportioning - Direct (cooling) 4=Time Proportioning - Reverse (heating) 5=Current Proportioning - Direct (cooling) 6=Current Proportioning - Reverse (heating) 7=Position Proportioning Reverse - Close	0	
6	Output 2 Percent Limit	o2PL	0 to 100 %	100	

STEP	DESCRIPTION	DISPLAY CODE	AVAILABLE SETTINGS	FACTORY SETTING	YOUR SETTING
7	Output 3	ouI3	0=None 1=Process Alarm - Direct 2=Process Alarm - Reverse 3=Deviation Alarm - Direct 4=Deviation Alarm - Reverse 5=Deviation Band Alarm- Open within band 6=Deviation Band Alarm- Closed within band	0	
8	Relay A Assignment	rLyA	0=Not Assigned 1=Assigned to Output 1 2=Assigned to Output 2 3=Assigned to Output 3 4=Assigned to Event 1 5=Assigned to Event 2 6=Assigned to Event 3	1	
9	Relay B Assignment	rLyb	Same selection as Relay A	2	
10	Relay C Assignment	rLyC	Same selection as Relay A	3	
11	Display Select	dISP	1=Process Value 2=Process Value & Setpoint 3=Process Value Deviation 4=Process Value Deviation & Setpoint 5=Setpoint	1	
12	Decimal Position (dPoS can be 2, 3, &4 if Euu is selected)	dPoS	0 or 1 decimal place	0	
13	Engineering Units Upper Value	Euu	-9999 to 9999 units	1000	
14	Engineering Units Lower Value	EuL	-9999 to 9999 units	0	
15	Hysteresis	HySI	0 to 300 degrees (width of hysteresis band, see Page 68)	3	
16	Setpoint Upper Limit (SPuL -EO option)	SPL	-9999 to 9999 degrees	1400	
17	Setpoint Lower Limit (EO Option)	SPLL	-9999 to 9999 degrees	0	
18	Automatic Transfer	AtFr	0=No automatic transfer 1=Transfer when temperature goes below setpoint 2=Transfer when temperature goes above setpoint	0	

NOTE:
When changing the Decimal position **dPoS**, the operator **MUST** ensure that all values previously programmed or tuned are now valid with the entry of a decimal point.

STEP	DESCRIPTION	DISPLAY CODE	AVAILABLE SETTINGS	FACTORY SETTING	YOUR SETTING
19	Profile Time Base	Ptb	1=HHH.T - Hours & Tenths 2=HH.MM - Hours & Min. 3=MM.SS - Minutes & Sec. <u>EO Option</u> 4=XXX.X-Units per hour ramp rate 5=XXX.X-Units per hour ramp rate 6=XXX.X-Units per minute ramp rate	3	
20	Profile Interrupt Action	PIA	0=Go to Off mode 1=Continue profile 2=Go into hold condition 3=Restart at the beginning of the profile	1	
21	Remote Run/Hold	rrH	0=Not selected 1=Selected. Remote Run/Hold will override controller front panel when placed in hold from remote source 2=Selected. Remote Run/Hold will not override controller front panel when placed in hold from remote source	0	
22	Process Filter Factor	PFF	1 to 20 (# of scans aver.) 1=No filtering	1	
23	Display Filter Factor	dFF	1 to 20 (# of scans aver.) 1=No filtering	1	
Parameters 24 - 28 are for Extended Option (EO) Only					
24	Current Output 1 Range	Co1r	0=0 to 20 mA 1=4 to 20 mA	1	
25	Current Output 2 Range	Co2r	0=0 to 20 mA 1=4 to 20mA	1	
26	Process Output	Pout	0=Not selected 1=Process Assigned to Current Output 1 2=Process Assigned to Current Output 2 3=Setpoint Assigned to Current Output 1 4=Setpoint Assigned to Current Output 2	0	
27	Process/Setpoint Output Upper Value	Pou	-9999 to 9999	2000	
28	Process/Setpoint Output Lower Value	PoL	-9999 to 9999	0	

STEP	DESCRIPTION	DISPLAY CODE	AVAILABLE SETTINGS	FACTORY SETTING	YOUR SETTING
------	-------------	--------------	--------------------	-----------------	--------------

Parameters 29 - 31 are for Communications Option Only

29	Communications Configuration	CCon	0=Off 1=Monitor only (read only) 2=Normal mode (read and write) 3=Total Access with Limit Checking 4=Total Access without Limit Checking	0, 4*	
30	Communication Bit Rate Select	CbS	1=300 bits per second (bps) 2=600 bps 3=1200 bps 4=2400 bps 5=4800 bps 6=9600 bps	6	
31	Communication Address	CAd	0 to 99	0, 1*	

** Factory setting for Total Access*

TABLE 3-2 TUNE MODE CONFIGURATION PROCEDURE

The Tune mode allows the entry, review or altering of the process control Tune adjustments and the alarm setting.

To enter the Tune mode, press and release the SCROLL key until **tunE** is displayed, then press the DOWN key. Press the SCROLL key to advance the display through the parameters and their values. Use the UP and DOWN keys to select (adjust) the values. Each time the DOWN key is pressed while a parameter code is being displayed, such as **dFF**, the next parameter code in the sequence will be displayed.

After selecting a parameter, to exit the mode, press the SCROLL key to proceed to the next parameter. After all selections have been made, press the UP key with a parameter in the display (not a setting).

For illustration purposes, all available Tune mode parameters have been listed. The parameters that will appear on the specific instrument will depend upon the parameter selection previously made in the Program mode.

For future reference, record the parameter selections for the application in the "Your Setting" column and on the Software Reference Sheet in Appendix E (page 75).

To prevent unauthorized changes to the Tune mode, the mode can be disabled (turned off) in the Enable mode.

The Tune mode is adjusted on-line. The instrument will react to changes as they are made.

STEP	DESCRIPTION	DISPLAY CODE	AVAILABLE SETTINGS	FACTORY SETTING	YOUR SETTING
1	Second Output Position	SPrd	-1000 to 1000 units	0	
2	Process Alarm	PAL	-9999 to 9999 units*	0	
3	Deviation Alarm	dAL	-3000 to 3000 units*	0	
4	Deviation Band Alarm	dbAL	1 to 3000 units*	1	
5	1st Output Proportional Band Width	Pb1	1 to 3000 units	100	
6	2nd Output Proportional Band Width	Pb2	1 to 3000 units	100	
7	Manual Reset	rSEt	-1500 to 1500 units	0	
8	Automatic Reset (integral)	ArSt	0.0 to 100.0 repeats per minute	0.0	
9	Rate (or Derivative)	rAtE	0.0 to 10.0 minutes	0.0	
10	Cycle Time Output 1	Ct1	1 to 240 seconds	30	
11	Cycle Time Output 2	Ct2	1 to 240 seconds	30	
12	Position Proportioning Sensitivity	SEnS	0.0 to 50.0%	1.0	
13	First Output Position	FoP	-1000 to 1000 units	0	

* See Section 4.2, page 44 for explanation of setting alarms.

TUNE MODE FLOW CHART

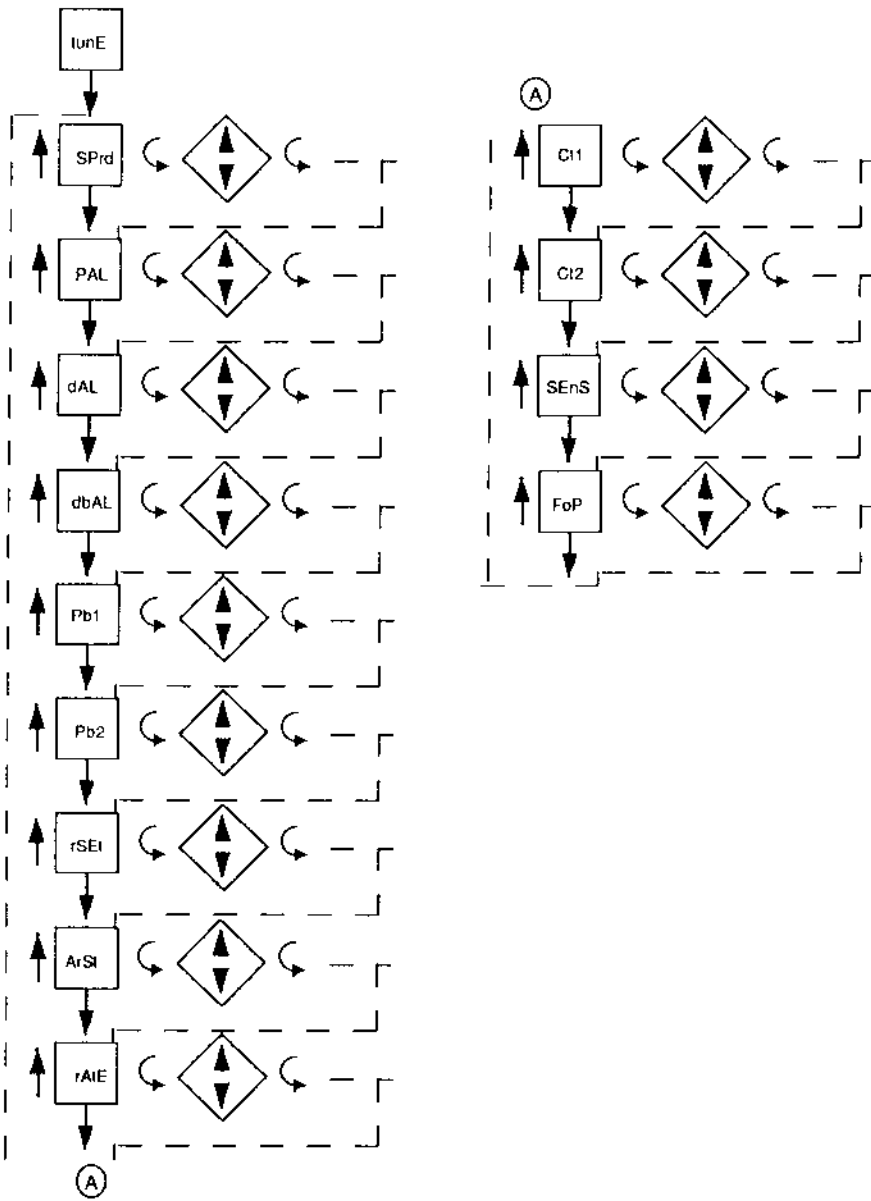

Key

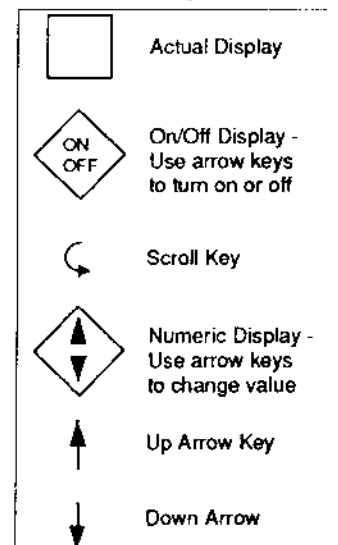

PROFILE ENTRY MODE FLOW CHART

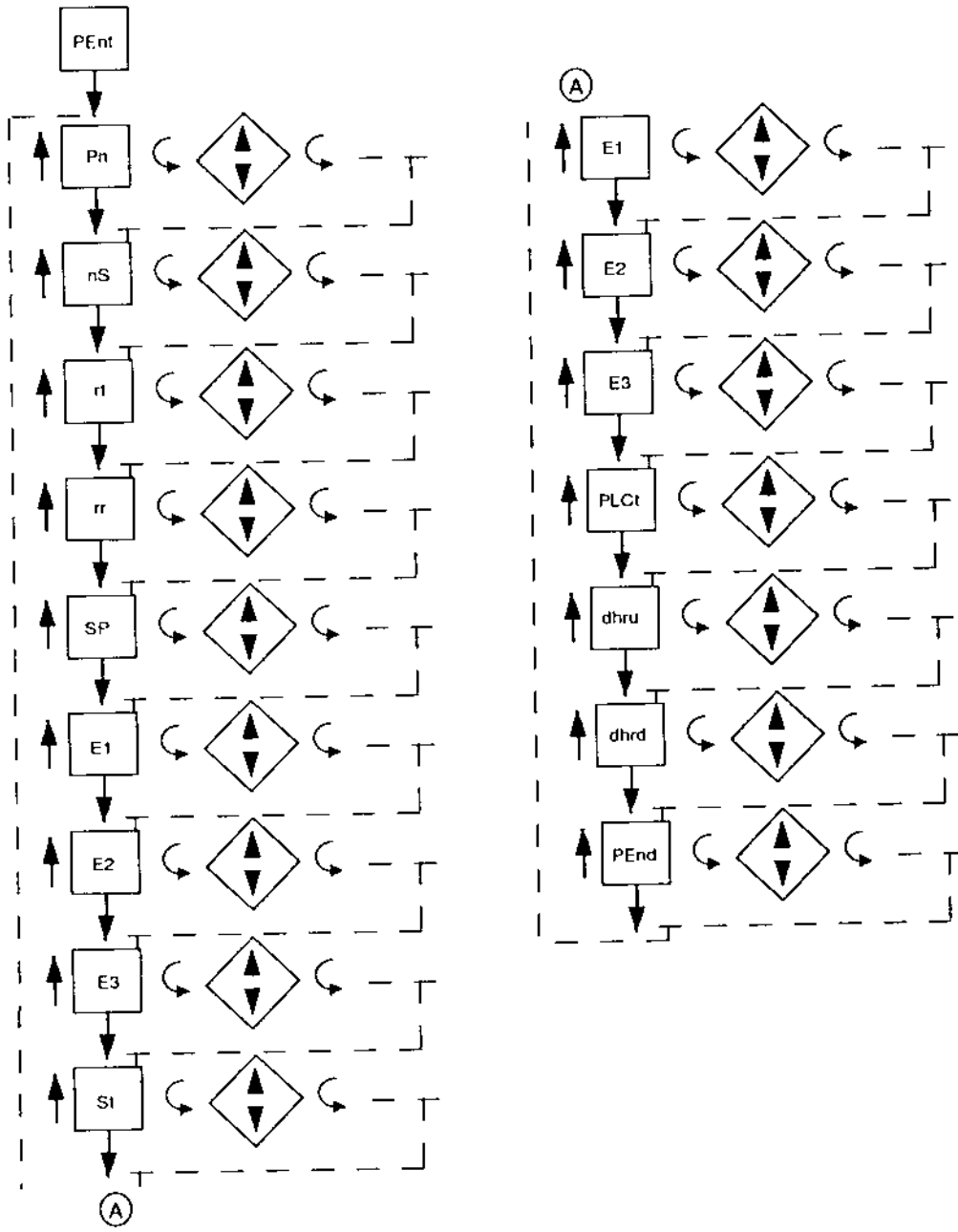

Key







-  Actual Display
-  On/Off Display - Use arrow keys to turn on or off
-  Scroll Key
-  Numeric Display - Use arrow keys to change value
-  Up Arrow Key
-  Down Arrow

TABLE 3-3 PROFILE ENTRY MODE CONFIGURATION PROCEDURE

Depress and release the SCROLL key until **Pent** is displayed. Use the DOWN key to enter the Profile Entry mode. Depress the SCROLL key to scroll through the parameters and their values. Use the UP and DOWN keys to adjust the values. After adjusting a parameter, depress the SCROLL key to proceed to the next parameter. After all selections have been made, to exit the mode, depress the UP key with a parameter in the display (not a setting). For assistance in developing the Profile refer to Appendix F (page 78).

STEP	DESCRIPTION	DISPLAY CODE	AVAILABLE SETTINGS	FACTORY SETTING	YOUR SETTING
1	Profile Number	Pn	1 to 8	**	
2	Number of Segments	nS	0-6 segments	**	
Steps 3-11 are repeated for each segment					
3	Ramp Time	rt	0 to 9999 units per Ptb	**	
3	*Ramp Rate	rr	0 to 9999 units per Ptb	**	
4	Setpoint	SP	Setpoint at end of Ramp	**	
5	Event Output 1	E1	on or off	**	
6	Event Output 2	E2	on or off	**	
7	Event Output 3	E3	on or off	**	
8	Soak Time	St	0 to 9999 units per Ptb	**	
9	Event Output 1	E1	on or off	**	
10	Event Output 2	E2	on or off	**	
11	Event Output 3	E3	on or off	**	
* Will be displayed instead of Ramp Time rt if Ramp Rate is utilized (see Ptb , EO Option only, page 29).					
12	Profile Loop Count	PLCt	0 to 9999, 0-continuous	**	
13	Deviation Hold after Ramp Up	dhru	0 to 3000 units 0=no auto hold	**	
14	Deviation Hold after Ramp Down	dhrd	0 to 3000 units 0=no auto hold	**	
15	Profile End control	PEnd	-1=Hold at last setpoint 0=Abort - all outputs off or at 0% Events off 1=Transfer to profile 1 2=Transfer to profile 2 3=Transfer to profile 3 4=Transfer to profile 4 5=Transfer to profile 5 6=Transfer to profile 6 7=Transfer to profile 7 8=Transfer to profile 8	**	

After selecting the Profile End Control parameter value, press the SCROLL key to advance the display to **Pn**. Press the UP key with **Pn** or any parameter code displayed to exit the Profile Entry Mode. (Continued on next page)

**All values except Profile Loop Count (PLCt) are initialized to zero and all event outputs are initialized to OFF, with the exception of the first profile. Profile Loop Count (PLCt) is set to 1.

The first profile has the number of segments initialized to zero, to turn the profile OFF, but the profile has values stored in it for demonstration purposes. By setting the number of segments to two, the profile can be reviewed and/or executed.

PROFILE 1 VALUES FOR DEMONSTRATION PURPOSES

<u>Code</u>	<u>Value</u>	
rt	.10	Ramp Time
SP	100	Setpoint
E1	on	Event 1 on
E2	oFF	Event 2 off
E3	oFF	Event 3 off
St	.10	Soak Time
E1	oFF	Event 1 off
E2	on	Event 2 on
E3	oFF	Event 3 off
rt	.10	Ramp Time
SP	0	Setpoint
E1	oFF	Event 1 off
E2	oFF	Event 2 off
E3	on	Event 3 on
St	.10	Soak Time
E1	oFF	Event 1 off
E2	oFF	Event 2 off
E3	oFF	Event 3 off
PLCt	1	Profile Loop Count
dhru	0	Deviation Hold after Ramp Up - None
dhrd	0	Deviation Hold after Ramp Down - None
PEnd	0	Profile End Control - Abort - oFF Mode

TABLE 3-4 ENABLE MODE CONFIGURATION PROCEDURE

To enter the Enable mode, press and hold the UP and DOWN keys while in **Ctrl** or **oFF** modes. All the display lamps will light. After 10 seconds, the lamps will go out and **EnAb** will be displayed. Release the keys and the display will change to **EtSt**. Press and release the DOWN key and each mode to be enabled/disabled will be displayed. With the Enable mode prompt for the desired mode displayed, press the SCROLL key to verify that the displayed mode is either **on** (enabled) or **oFF** (disabled). Press the DOWN key to turn off the mode, press the UP key to turn on the mode or press the SCROLL key to advance the display to the next Enable mode prompt. Use the "Your Setting" column in the table to record your programming.

A Hardware jumper located on the Controller Board (See Appendix A-2, page 64) can be used to lock/unlock the Enable mode. When the jumper is moved to the locked position, entry into the Enable mode is not possible until the jumper is moved to the unlock position.

STEP	DESCRIPTION	DISPLAY CODE	AVAILABLE SETTINGS	FACTORY SETTING	YOUR SETTING
1	Test Mode	EISL	on or oFF	<i>oFF</i>	
2	Calibration Mode	ECAL	on or oFF	<i>oFF</i>	

STEP	DESCRIPTION	DISPLAY CODE	AVAILABLE SETTINGS	FACTORY SETTING	YOUR SETTING
3	Program Mode	EPro	on or oFF	<i>on</i>	
4	Tune Mode	Etun	on or oFF	<i>on</i>	
5	Manual (Stby) Mode	ESby	on or oFF	<i>on</i>	
6	Profile Continue Mode	EPC	on or oFF	<i>oFF</i>	
7	Profile Entry Mode	EPE	on or oFF	<i>on</i>	
8	Setpoint Change	ESPC	on or oFF	<i>on</i>	

ENABLE MODE FLOW CHART

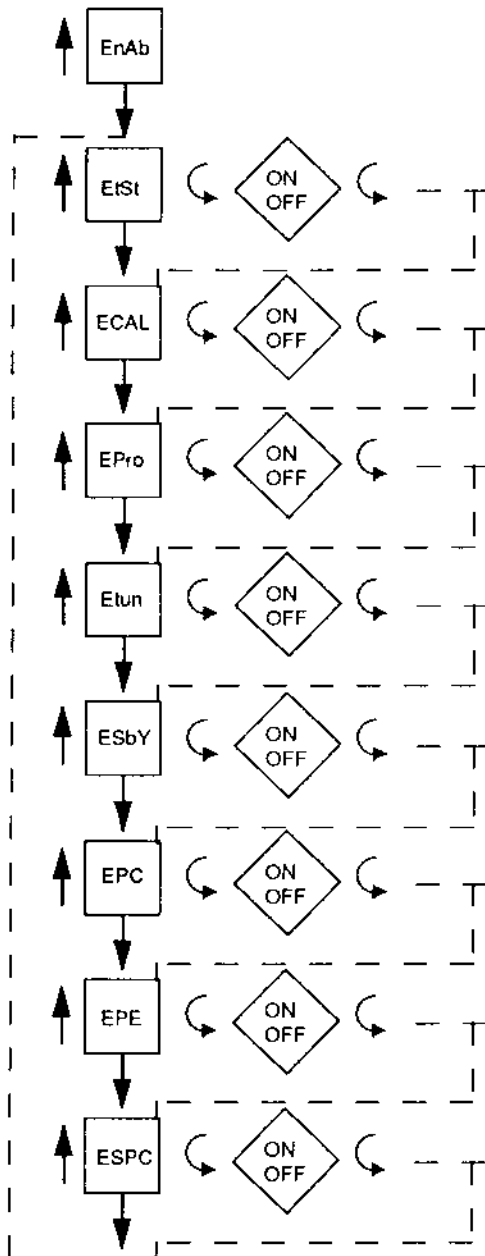

Key

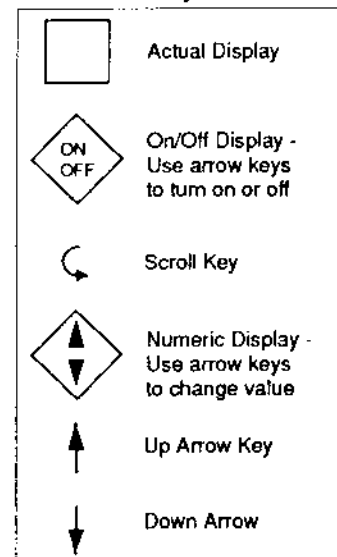

Operation 4.1

4.1.1 OFF MODE

In the Off Mode, the instrument control, process retransmission signal(s) and alarm function(s) are turned off. The Off mode can be entered by pressing and releasing the SCROLL key until the display reads **oFF**, then pressing the DOWN key. The display will read **oFF** and then the current process variable at two second intervals. This sequence will repeat to indicate that the instrument is in the Off mode.

4.1.2 CONTROL MODE

In the Control mode, the instrument control function(s) and alarm(s) are actively responding to the process variable as selected in the Program and Tune modes. The control mode allows setpoint changes from local setpoint (standard) adjustment by an operator at the front keypad. Other operations in the Control mode include a lamp test and proportional output % display.

4.1.2.1 DIRECT/REVERSE OPERATION OF OUTPUTS

Direct operation is typically used with cooling applications. On-Off direct output(s) will turn on when the process variable exceeds setpoint. Proportional direct output(s) will increase the percentage of output as the process value increases within the proportional band.

Reverse operation is typically used with heating applications. On-Off reverse output(s) will turn off when the process variable exceeds setpoint. Proportional reverse output(s) will decrease the percentage of output as the process value increases within the proportional band.

4.1.2.2 LOCAL SETPOINT OPERATION

The instrument must be in the Control mode to allow the setpoint value to be adjusted. In the Control mode, to view the setpoint, press and release the UP or DOWN key. The green LED under the SP label will light to indicate that the displayed value is the setpoint. To change the setpoint value, press and hold the appropriate key. Press and hold the UP key to increase the setpoint or press and hold the DOWN key to decrease the setpoint. The setpoint will change slowly at first then faster as the key is held pressed. If the setpoint will not increase, check the Program mode (page 25) to see that you are not trying to increase the setpoint above the setpoint limit **SPL**. Check that the Setpoint Change mode is on in the Enable mode.

4.1.2.3 PROFILE OPERATION

To start a profile, press and release the SCROLL key to sequence the display to the profile number display code **P1**, **P2**, etc. With the desired profile number displayed, press either the DOWN or the RUN/HOLD to start the profile. **run** will be displayed for about 2 seconds to indicate that the profile is starting. The status lamps will indicate which segment is active and if the profile is in the ramp or soak portion of the segment.

To stop a profile that is running, press the RUN/HOLD key. The display will show **hold** for about 2 seconds, then the process value for about 2 seconds and then continue to display this sequence. The profile timer will stop but the control, alarm, and event outputs will remain active. The profile can be restarted by pressing the RUN/HOLD key. To exit the profile, go to hold and then press and release the SCROLL key until the display shows **oFF** or **Ctrl**, then press the DOWN key. Pressing the DOWN key with **oFF** displayed will cause the control, alarm, and events to be turned off. (Pressing the DOWN key with **Ctrl** displayed will leave the events as they were, and the control and alarm outputs will remain active). The setpoint will be the last setpoint seen in the profile.

While a profile is running, it is possible to display additional profile status information. To activate the Profile Execution Status Display sequence, hold the DOWN key and press the SCROLL key. This will cause the display to sequence through the following series of display codes and values:

Display Code	Description	Value
Pn	Profile Number	Actual Profile Number
tr	Time remaining in current Ramp or Soak	Actual time remaining value (in whatever units were configured in the program mode for Pt _b)
E1, E2, E3	Event 1-3 status (if applicable)	on or off
SP	Current Setpoint	Actual Setpoint Value
ProC	Current Process Value	Actual Process Value
PLCt	Profile Loop Count remaining	Profile Loop count Value

Each code or value will only be displayed if they are appropriate. Each code or value will be displayed for one second. This sequence will continue until any key is depressed.

To start a profile running at some point within the profile other than start can be accomplished by using the Profile Continue mode. Press and release the SCROLL key until display is PCon, then press the DOWN key. The display will be Pn; adjust the profile parameter values as needed in the Profile Continue Configuration mode, then press the RUN key. The instrument will execute the profile selected as directed by the information entered in the Profile Continue mode. See Table 4-1, page 40. If you are running a profile and it is desired to alter the profile you must go to hold and then scroll to the Off or Control mode before entering Pcon.

Note: Pcon is not available when Profile Time Base (Pt_b) in Program mode has been set for Units Ramp Rate (EO Option).

PROFILE CONTINUE MODE FLOW CHART

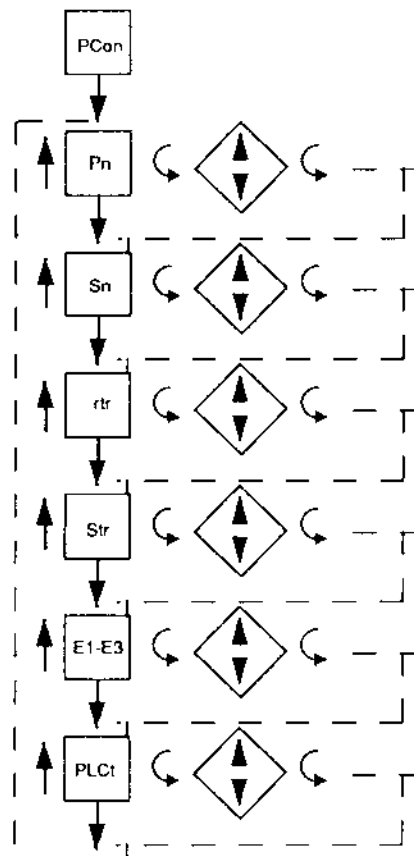

Key

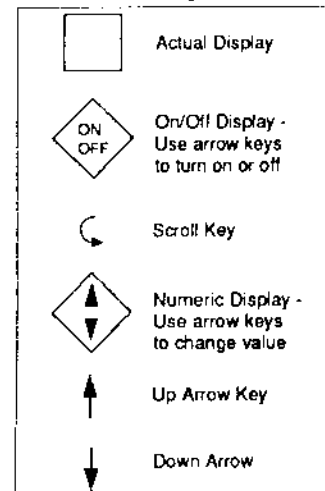

**TABLE 4-1 PROFILE CONTINUE MODE - Not available when Ptb=4, 5, or 6
(EO Option only)**

STEP	DESCRIPTION	DISPLAY CODE	ACTION
1	Profile Number	Pn	Press the SCROLL key to see the number of the last active profile.
2	Profile Number Value	X	If necessary, use the UP or DOWN key to change the profile number to the desired value, then press the SCROLL key.
3	Segment Number	Sn	Press the SCROLL key to see the number of the last active segment.
4	Segment Number Value	X	If necessary, use the Up or Down key to change the segment number to the desired value, then press the SCROLL key. DO NOT SET THIS VALUE TO 0 AND ATTEMPT TO RUN THE PROFILE. AN ERROR 19 WILL DISPLAY AND THE PROFILE WILL NOT RUN.
5	Ramp Time Remaining	rtr	Press the SCROLL key to see the Ramp Time Remaining value.
6	Ramp Time Remaining Value	X	If necessary, use the UP or DOWN key to adjust the Ramp Time Remaining value, then press the SCROLL key. If the time remaining is set to 0 when the SCROLL key is pressed, the Soak Time Remaining code will be displayed. If the time remaining is greater than 0, then the display will advance to the Profile Loop Count code.
7	Soak Time Remaining	Str	Press the SCROLL key to see the Soak Time Remaining value of the last active profile.
8	Soak Time Remaining Value	X	If necessary, use the UP or DOWN key to adjust the Soak Time Remaining value, then press the SCROLL key.
9	Event(s)	E1-E3	If any event outputs have been selected in the Program mode then each event number selected will be displayed in sequence. Press the SCROLL key to see the status of the event(s).
10	Event(s) Status	on/oFF	If necessary, use the UP key to turn on an event that is off or the DOWN key to turn off an event that is on. Press the SCROLL key to see the next event number. After the last event status is selected, pressing the SCROLL key will advance the display to be PLCT.

4.1.2.7 POSITION PROPORTIONING CONTROL

Position Proportioning control can be implemented on those controllers provided with two SPST relay outputs or two SSR Driver outputs and Slidewire Feedback option.

Positioning proportioning control permits the use of PID control where the final control element is a modulating device such as a motorized valve. In this form, each of the two required relays or SSR Drivers will be used to control the valve. One output is used to open the valve, the other is used to close the valve. The slidewire feedback is used to provide a signal relative to the valve armature position to the instrument.

As with the other proportioning control forms, the process input, tuning parameters and the setpoint are used by the control algorithm to calculate the output % required to correct for the deviation between setpoint and process.

With Position Proportioning control, it may be necessary to adjust the Sensitivity (**SEnS**) Tune mode parameter to reduce or eliminate oscillations of the motor around setpoint. If oscillation occurs, increase the **SEnS** value until the motor stops oscillating. If the differential between the Open and Closed rotation is too large, then decrease the **SEnS** value. Also, for proper Position Proportioning operation, it is necessary to specify the actuation time of the valve or damper from full open to full closed. If the motor has a stroke duration of 60 seconds, change the value in the Cycle Time parameter **Ct1** to 60. This ensures that the controller will move the motor for the proper amount of time when making adjustments.

4.1.2.8 DUAL OUTPUT CONTROL

Dual output control can be performed when two outputs are specified. The outputs may be programmed for On-Off, Time Proportioning, or Current Proportioning, as applicable.

The output action is dependent upon the setpoint, the process value, and Tune mode parameters. If two proportional outputs are selected, both output proportional bands will be biased so that 0% of output is seen when the process value equals setpoint. The output(s) can be biased by the use of the Tune mode parameters **FOP** and **SPrd** as shown in Figure 4-1 (below).

The first output is programmed as a proportional reverse output and the second as a proportional direct output. (See Glossary, page 67, for definitions of these terms). Dual proportioning outputs are provided with separate proportional bands and cycle time adjustments for each output.

FIGURE 4-1

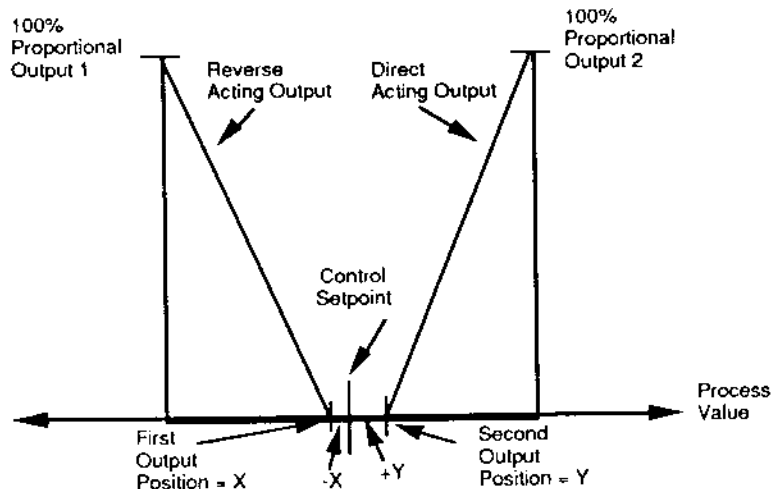

4.1.2.9 PROPORTIONAL OUTPUT PERCENTAGE DISPLAY

While in the Control mode, press and hold the UP key and then press the SCROLL key to cause the display to sequence through a series of display codes and values:

Po1	Percent Output 1 (if applicable)	Output 1% value
Po2	Percent Output 2 (if applicable)	Output 2% value
Proc	Process Value	Actual Process Value

Each code and output value will be displayed only if the corresponding proportional output is present. Each code or value will be displayed for 1 second. This sequence of displays will continue until the SCROLL key is pressed, which will then return the display to the normal mode.

4.1.3 MANUAL MODE FOR PROPORTIONAL OUTPUTS

Manual adjustments of the proportional output(s) can be used to test the operation of the output(s), while tuning to establish basic process control, or to provide control of the proportional output(s) during the occurrence of certain error conditions.

Note: *The proportional output(s) do not change automatically in response to changes in the process while in the Manual mode. Be sure to pay close attention to the process to avoid damage.*

To enter the Manual mode, press and release the SCROLL key until you see **Stby**. Then press the DOWN key. The Manual mode status LED will light to indicate that the Manual mode is in use. Shifting from the Control to the Manual mode is bumpless. The proportional output(s) will stay at the last value(s) calculated by the control algorithm. **Po1** will appear on the display if output 1 is a proportional output or **Po2** if output 1 is not a proportional control. If no keys are pressed, the display will sequence through the following displays:

- Po1** if output 1 is 3, 4, 5, 6, 7 then the output 1 percentage of output value
- Po2** if output 2 is 3, 4, 5, 6 then the output 2 percentage of output value.
- Proc** will be displayed, then the current process value.

In order to vary a proportional output percentage value, press and release the SCROLL key until the display code for the output is displayed **Po1** or **Po2**. Press and release the SCROLL key again to see the percentage of output value. Press the UP key to increase the output percentage value. Press the DOWN key to decrease the output percentage value.

To return to the Control mode of operation from the Manual mode, press the SCROLL key until you see **Po1** or **Po2** then press the UP key. The display will change to **Stby**. Press the SCROLL key until you see the mode you wish to enter, then press the DOWN key. If the Automatic Transfer feature is selected in the Program mode, the instrument will switch from Manual mode to the Control mode when process value reaches the setpoint value.

4.1.4 PROCESS RE-TRANSMISSION OUTPUT - EO OPTION ONLY

If the instrument is provided with a current output not used for process control, this output may be assigned to provide a linear re-transmission of the process value. This output can be used to provide a process signal to remotely installed recorders, panel meters, or dataloggers. The process output is scaled for the application by using the Program mode parameters process/setpoint value upper **Pou** and process/setpoint value lower **PoL**. The current output resolution is @ 200 steps, so for the best re-transmission accuracy, the span between **Pou** and **PoL** should be as small as possible. If a current output is used for re-transmission, the corresponding control output, **out1** or **out2**, cannot be assigned to it.

Upon an error condition, Process Value output will be set to 0 percent if the 1st output control is direct acting. If the control action is reverse acting, the Process Value output will be set to 100 percent.

4.1.5 SETPOINT RE-TRANSMISSION OUTPUT - EO OPTION ONLY

If the instrument is provided with a current output not used for process control, this output may be assigned to provide a linear re-transmission of the setpoint value. The setpoint output is scaled for the application by using the Program mode parameters process/setpoint output value upper **Pou** and process/setpoint output value lower **PoL**. The current output resolution is @ 200 steps, so for the best re-transmission accuracy, the span between **Pou** and **PoL** should be as small as possible. If a current output is used for re-transmission, the corresponding control output, **out1** or **out2**, cannot be assigned to it.

Alarm Operation 4.2

The type of alarm is selected in the Program mode as follows:

1. Process Alarm Direct - the alarm will be **on** if the process value is greater than the process value selected.
2. Process Alarm Reverse - the alarm will be **on** if the process value is less than the process value selected.
3. Deviation Alarm Direct - the alarm will be **on** if the process value is greater than the setpoint plus the deviation value selected.
4. Deviation Alarm Reverse - the alarm will be **on** if the process value is less than the setpoint plus the deviation value selected.
5. Deviation Band Alarm Open Within - the alarm will be **on** if the process value is greater than one half the deviation band alarm values selected above or below the setpoint.
6. Deviation Band Alarm Closed Within - the alarm will be **on** if the process value is less than one half the deviation band value selected above or below the setpoint.

The alarm will be active while the instrument is in the Control mode or while the profile is running. Relay and solid state relay drivers can be assigned to provide output capability to the alarm function.

The alarm value (Process, deviation or bandwidth) is selected in the Tune mode.

Alarm output chatter can be reduced by using the hysteresis parameter in the Program mode to create a deadband around the alarm point.

Tune Mode Operation 4.3

Proportional output control may require the adjustment (tuning) of the PID and other related parameters. This provides a means for the instrument's control algorithm to be adjusted to meet specific application requirements.

4.3.1 SYSTEMATIC TUNING METHOD

1. Changes in tuning parameters should be made one at a time.
2. After making any changes in tuning parameters, a disturbance should be introduced into the process so that the process reaction may be observed. This process reaction, or recovery, will tell whether the tuning parameters provide the desired control. It is usually easiest to make a step change in setpoint to introduce this disturbance.

3. The change in setpoint, or disturbance, referenced above should be large enough to cause an observable deviation of process from setpoint. However, this change should not be so large that it will cause the controller output to proceed to either extreme limit.
4. Controller tuning for optimal control is not hard and fast, BE PATIENT. The process will take a certain amount of time to react to the setpoint changes during tuning. The amount of time depends upon the specific process, however, a period of 8 to 12 minutes should be allowed between changes. The important point to remember is to allow the process to react completely, do not rush through tuning of the controller. If the complete process reaction is not observed, optimum control may never be achieved.
5. Time Proportioning control output(s) require(s) the cycle time to be adjusted for the application. Short cycle times typically result in the most accurate process control, but will cause the quickest wear out of any mechanical components.
6. Leave all other tuning parameters (except for the alarm settings, if used) at the factory default settings. Obtain the best possible process reaction by adjusting the Proportional Bandwidth parameter. The setting that achieves the best response for the process should be left in the controller programming, and should be noted on the Software Reference Sheet in Appendix E (page 75).
7. If there are to be no setpoint or load changes in the process, the Proportional Band adjustment may be all that is necessary for proper control. If an offset still exists (the process does not settle out at setpoint with the best possible proportional band adjustment) Manual Reset may be added to eliminate this offset.
8. Auto Reset may be added to eliminate offsets and improve response to setpoint and load changes. Increase Auto Reset from 0 in 0.2 increments. Start with a small amount. Increase this increment if there is no apparent reaction. Remember to allow the process 8 to 12 minutes to react.
9. If necessary, Rate may be added. Rate is a dynamic tuning parameter. Rate may be required to compensate for process lags or to help inhibit reset windup when a large amount of Auto Reset (4 or 5 repeats per minute) is being used.
10. Controller tuning is not hard and fast. It may be necessary to adjust the tuning parameters over a period of time to obtain optimal control of the process.

4.3.2 ZIEGLER NICHOLS TUNING METHOD

This procedure has been determined empirically to yield 1/4 amplitude decay tuning parameters that are determined by watching the system in a sustained oscillation (curve C, page 46) the ultimate proportional band and ultimate time period) and then using these values from this sustained oscillation to calculate ideal parameters.

Determining Ultimate Proportional Band and Ultimate Time Period

1. Set Manual Reset **rSet** to 0.0, set **ArSt** to 0.0 and set **rAtE** to 0.0
2. Enter the Control mode of operation, observe the process reaction.
3. Set the Proportional Band (PB) at 100 and upset the process and observe the response. One easy method for imposing the upset is to move the setpoint for a few seconds and then return it to its original value.

(Continued on next page)

4. Achieve a response curve similar to the sustained oscillation (curve C), this is the Ultimate Proportional Band (UPB) and Ultimate Time Period (UTP).

- a) If the response curve from step 3 does not damp out, as in Curve A from the drawing, the PB is too low. The PB should be increased and step 3 repeated.
- b) If the response in step 3 damps out, the PB is too high. The PB should be decreased and step 3 repeated.

These values obtained for Ultimate Proportional Band (UPB) and Ultimate Time Period (UTP) are used to calculate ideal P, PI, PD, PID tuning parameters using the following Ziegler-Nichols equations:

Proportional only control (P) -

$$P(Pb) = 2 \times UPB \text{ (degrees or units)}$$

Proportional plus automatic reset (PI) -

$$P(Pb) = 2.2 \times UPB \text{ (degrees or units)}$$

$$I(ArSt) = 1.2 / UTP \text{ (repeats per minute)}$$

Proportional plus derivative (or rate) (PD) -

$$P(Pb) = 1.7 \times UPB \text{ (degrees or units)}$$

$$D(rAtE) = UTP / 8 \text{ (minutes)}$$

Proportional plus automatic reset plus derivative (PID)

$$P(Pb) = 1.7 \times UPB \text{ (degrees or units)}$$

$$I(ArSt) = 2 / UTP \text{ (repeats per minute)}$$

$$D(rAtE) = UTP / 8 \text{ (minutes)}$$

If an overdamped response is desired, multiply the proportional band by two.

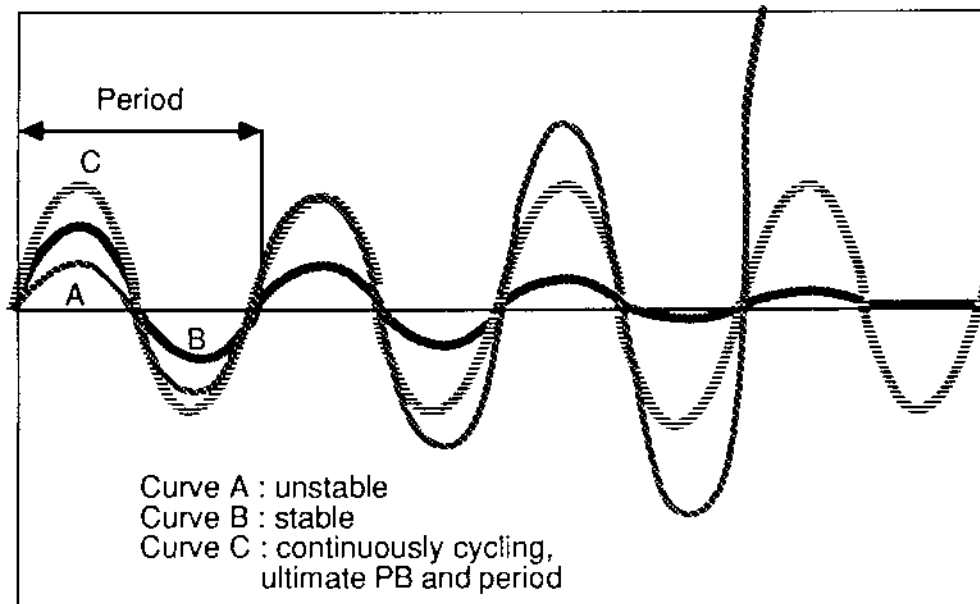

Service 5.1

This section contains Calibration, Test and Trouble-shooting procedures that can be performed by the user. Instruments are calibrated to all input type specified when ordered at the factory prior to shipment. Re-calibration should not be necessary under normal operating conditions.

Calibration 5.2

Caution: Do not attempt any of these calibrations without the proper test equipment with specifications equal to or better than those listed.

Press and release the SCROLL key to sequence the display until **CAL** appears. If **CAL** does not appear, refer to Section 3 for instructions on how to enable the Calibration mode. When **CAL** appears on the display, press the DOWN key. The display will read **CAL 1**. **CAL 1** can be initiated at this time or press the SCROLL key to advance the display to other calibrations available.

CALIBRATION FLOW CHART

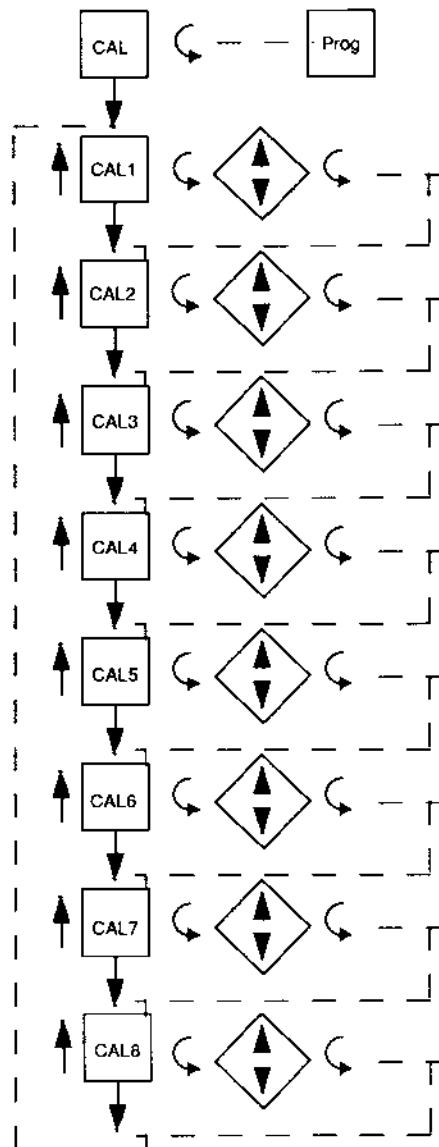

Key

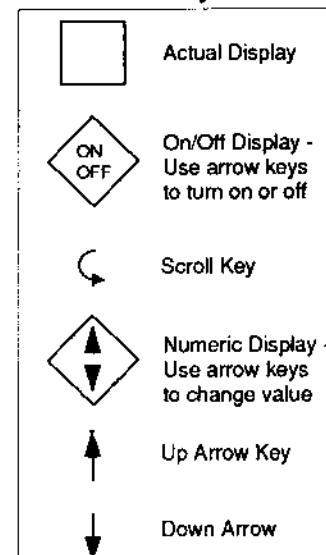

TABLE 5-1 CALIBRATION PROCEDURES

<u>Calibration Procedure</u>	<u>Description</u>
CAL 1	Re-initialization of Program and Tune mode values.
CAL 2	Main Calibration used by all inputs. This is the only calibration required for voltage and millivolt inputs.
CAL 3	Cold Junction Compensation calibration used to correct for component variation in CJC circuit.
CAL 4	Cold Junction utility. The temperature of the cold junction is displayed. No adjustment is made with this procedure.
CAL 5	RTD input calibration used to correct for component differences in the RTD input circuit.
CAL 6	CJC turn on/off.
CAL 7	Factory Use Only.
CAL 8	Re-initialization of all profile information

5.2.1 CAL 1 PARAMETER INITIALIZATION

This procedure is performed to erase the information that was entered in the Program and Tune modes. All parameters will be reset to default values. Prior to beginning this procedure record the Program and Tune mode parameters so that they can be re-entered. No special test equipment is required.

With **CAL 1** displayed, depress and hold the DOWN key, then press the SCROLL key. The display will momentarily go blank. Release the keys. **CAL 1** will reappear on the display. This calibration can be done again or another may be selected.

5.2.2 CAL 2 MAIN CALIBRATION

This procedure determines and saves calibration values which correct for component variations relating to the input measuring function of the instrument. This is the only calibration required for the volt and millivolt inputs. Additional calibration procedures are required for thermocouple and RTD inputs.

A $50.00 \pm .01$ mVDC source is required for calibrating. In addition, make sure that JU1 on the Processor board is in the "non volt" position. See Appendix A-2 (page 64).

Make sure all input wiring is disconnected. Short the input terminals 1 and 3 or apply $0.00 \pm$ mV to the input. With **CAL2** displayed, press and hold the DOWN key, then press the SCROLL key. Release both keys and the instrument will display **hLd1**. Depress the DOWN key; **dELy** will appear for up to ten seconds, then **SCAn** will appear for up to ten seconds. If the calibration reference number which appears is not between -50 and +50, proceed per note below. Otherwise, connect a $50.00 \pm .01$ mV source to the input terminals. Press the DOWN key and **dELy** will be displayed for ten seconds and the **SCAn** for ten seconds. Then **CAL2** will reappear. If there is a problem, the appropriate error code will be displayed. Restore JU1 to the position necessary for the input type.

NOTE: If the calibration reference number falls outside the -50 to +50 range, depress the **SCROLL** key and **CAL2** will be displayed. Depress the **DOWN** key and perform the calibration once more. Repeat the calibration until the number falls within the tolerance limits. If the calibration number remains outside these limits, check the connections to the test equipment and try the calibration again. If the number still does not approach the tolerance limits contact an Applications Service Engineer at the factory or a local representative.

Error Recover - see 5.4 (page 56) for details. However, be sure that the millivolt source is securely connected, functioning properly and the polarity is correct. Press the **DOWN** key to bring the instrument back to **dELy** and try the calibration again. The calibration can be exited at anytime. **hLd1** or the reference number is displayed by pressing the **SCROLL** key.

CAL 2 QUICK CALIBRATION

This routine will allow the operator to execute a rough calibration on their unit via the keypad with no other equipment or disturbance to established wiring. It is intended to provide a partial recovery from a calibration corruption where the necessary equipment indicated in Cal 2-5 may not be available. It should be noted that this is not intended as a substitution to the main calibration procedure described earlier and may considerably deter from the accuracy of the instrument.

With **CAL2** displayed, press and hold the **DOWN ARROW** key, then press the **SCROLL** key. Release both keys and the instrument will display **hLd1**. Press and hold the **UP ARROW** key, then press the **SCROLL** key. The display will momentarily blank and then **CAL1** will be displayed. Release both keys and depress the **UP ARROW** key. **CAL** will be displayed.

5.2.3 CAL 3 COLD JUNCTION COMPENSATION

This procedure determines and saves calibration values which correct for component variations relating to the cold junction compensation. This calibration must be preceded by **CAL2** the main calibration, to properly calibrate the instrument. These two calibrations are all that is needed for proper operation with thermocouple inputs.

Test equipment: : one type J thermocouple and one mercury thermometer, accurate to $\pm .25$ degrees C or equivalent are required.

Make sure all input wiring is disconnected and connect the J thermocouple to the input. Place the thermometer next to the thermocouple and allow the controller to warm up for 30 minutes, before proceeding with the calibration.

With **CAL3** displayed, press and hold the **DOWN** key, then press the **SCROLL** key and the unit will display **hoLd**. Release both keys. Press the **DOWN** key and **dELy** will be displayed for ten seconds, then **SCAn** for ten seconds. If **SCAn** remains in the display for much longer than ten seconds, refer to the note below. The instrument will compute and display the cold junction temperature to the nearest tenth of a degree C. Compare reading with thermometer and use the **UP** and **DOWN** keys to correct the reading, if necessary. To end procedure, press the **SCROLL** key and **CAL3** will be displayed again.

NOTE: If the instrument continues to display in **SCAn**, proceed as follows. With **SCAn** displayed, press the **SCROLL** key. The instrument will display **hoLd**. Press the **UP** key. The instrument will begin the calibration procedure with a default value and proceed to **dELy**. Complete calibration as described above.

Error recovery - see section 5.4 (page 56) for details on specific errors. The calibration can be exited at any time. **hoLd** is displayed by pressing the **SCROLL** key.

5.2.4 CAL4 COLD JUNCTION UTILITY

This procedure displays the temperature the cold junction compensator is sensing. No test equipment is required.

With **CAL4** displayed, press and hold the DOWN key, then press the SCROLL key. Release both keys and **SCAN** will be displayed for 10 seconds while the instrument senses the CJC temperature. The result will then be displayed to a tenth of a degree C. The input terminals must be shorted. **CAL3** must first be performed. *The displayed temperature is not the ambient temperature. It is the temperature of the CJC.* To exit, press the SCROLL key and **CAL4** will be displayed.

5.2.5 CAL5 RTD INPUT

This procedure determines and saves calibration values relating to RTD inputs. This calibration must be preceded by **CAL2** to properly calibrate the instrument. A decade resistance substitution box with .01% resolution or equivalent is required. *Make sure that the Processor board jumper JU1 is in the non-volt position (Appendix A-2, page 64) and that the Option board jumpers JU2 and JU3 are in the proper positions (Appendix A-3, page 65).*

With **CAL5** displayed, press and hold the DOWN key and then press the SCROLL key. The display will now be **hLd1** to indicate that the instrument is set to calibrate the RTD input. Connect the decade box at 100 ohm setting across the input terminals 1 and 3 and a jumper wire from terminal 1 to 5. Press the DOWN key and **dELy** will be displayed for 10 seconds, then **SCAN** for ten seconds. When **hLd2** is displayed, change the decade box setting to 277 ohms to the input terminals (do not disturb the wiring) and press the DOWN key. The display will change to **dELy** for 10 seconds, followed by **SCAN** for ten more seconds. **CAL5** will be displayed after the calibration is completed.

Error recovery:

See section 5.4 (page 56) for details on specific errors.

The calibration can be exited when the instrument displays **hLd1** or **hLd2** by pressing the SCROLL key.

5.2.6 CAL6 COLD JUNCTION COMPENSATION

This routine provides selection of operating modes for the cold junction compensation used for thermocouple inputs.

With **CAL6** displayed, press and hold the DOWN key, then press the SCROLL key. The instrument will display **C6** and the number of the mode in effect. Press the UP or DOWN key to change the mode selection, indicated by the number to the right of the **C6**. Pressing the SCROLL key will exit the calibration with the last number displayed in effect.

The selected mode will remain in effect if power is interrupted. To return the instrument to normal operation, **CAL6** must be exited, with mode zero selected, or **CAL1** must be executed to initialize all parameters.

Mode 0: Normal operating mode.

Mode 1: Cold Junction Compensation temperature will be internally fixed at 0 degrees C by the software to facilitate linearization testing when using an uncompensated millivolt source to simulate thermocouple millivolt input signal.

Note: If the Process Value exceeds 999.9, the leftmost digit will be the letter o with a bar over it. The other digits will be valid.

5.2.7 CALB PROFILE REINITIALIZATION

This procedure is used to erase all profiles that have been entered in the instrument. Be sure to record any profile information on the Profile Recording Sheets (Appendix F, pages 78 and 79) so that they can be re-entered.

With **CALB** displayed, press and hold the DOWN key, then press the SCROLL key. The display will blank momentarily and then **CALB** will be displayed.

Test Mode Procedures 5.3

To enter the Test mode, press and release the SCROLL key until tESt appears on the display, then press the DOWN key. tSt1 will be displayed, press and release the SCROLL key to advance the display to the desired test. Test 1, 2 and 3 are performed as a unit so the display will advance directly to tSt4 from tSt1. Listed below in Table 5-2 are the test procedures available. Test 1, 2 and 3 are performed on start up, periodically during operation, and on entry into the Test mode. Test 4 is executed on entry into and periodically during the Operation mode. These tests can be used as a trouble shooting aid.

TEST MODE FLOW CHART

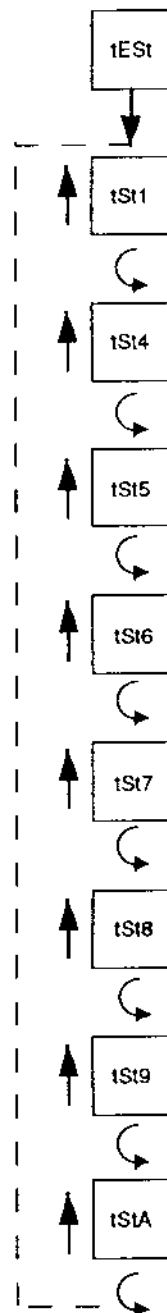
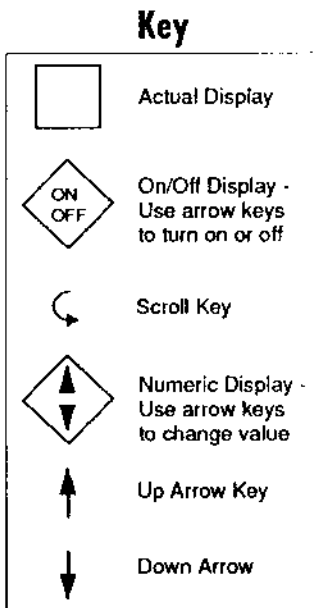

TABLE 5-2 TEST PROCEDURES AND DESCRIPTION

<u>Test</u>	<u>Description</u>
Test 1	Microprocessor internal RAM test. Used to check the processor RAM to make sure it is functioning correctly.
Test 2	External RAM test, used to test the RAM chip for proper function.
Test 3	EPROM checksum test, used to check that the EPROM program is correct.
Test 4	External RAM checksum test; instrument test and identifies how many times Errors 16, 17 and 18 have occurred.
Test 5	Verifies that all keys are functional and all LEDs are working.
Test 6	Used to verify that all relays and solid state relay driver outputs are working correctly.
Test 7	This procedure will allow operator to adjust the current output value to check the output and to test the operation of the external device.
Test 8	This is the same as Test 7 except it is for Output 2.
Test 9	Auxiliary Input Test. Allows for the viewing of the optional auxiliary input voltage level.
Test A	Communications Hardware Test

5.3.1 TEST 1 INTERNAL RAM TEST

Tests the Random Access Memory internal to the microprocessor. No special test equipment is required.

With **tSt1** displayed, press and hold the DOWN key, then press the SCROLL key. **tSt1** will be displayed momentarily while the test is in progress. Upon successful completion, the instrument will proceed to Test 2.

5.3.2 TEST 2 EXTERNAL RAM TEST

Tests the battery backed-up RAM external to the microcomputer. No special test equipment is required.

After completion of Test 1, **tSt2** will be displayed momentarily while the test is in progress. Upon successful completion, the instrument will proceed to Test 3.

5.3.3 TEST 3 PROGRAM EPROM TEST

This is a checksum test to verify data integrity of the stored program. No special test equipment is required.

After completion of Test 2, **tSt3** will be displayed momentarily while the test is in progress. Upon successful completion of Test 3, **tSt1** will be displayed.

5.3.4 TEST 4 EXTERNAL RAM CHECKSUM TEST

This is a checksum test to verify the integrity of data stored in RAM and indicate the number of times the instrument has had an Error 16, 17 and 18. The unit may have automatically recovered from these errors. No special test equipment is required.

With tSt4 displayed, press and hold the DOWN key, then press the SCROLL key. The display will blank momentarily, then momentarily display three numbers, and then tSt4 will be displayed. These numbers indicate the number of times Error 16, 17, and 18 have occurred respectively. Test 4 can be executed again, or another test may be selected.

5.3.5 TEST 5 KEYPAD/DISPLAY TEST

This test allows the operator to verify that the keys work and that all display elements can be lit. No special test equipment is required.

With tSt5 displayed, press and hold the DOWN key, then press the SCROLL key and then release both keys. The display will go blank. The following code will be displayed while the corresponding key is pressed:

Key	Display
SCROLL	SCrL
UP	uAro
DOWN	dAro
RUN/HOLD	run
UP and DOWN	(All LED's and segments lit)

To exit, press the SCROLL and UP key simultaneously, tSt5 will be displayed.

5.3.6 TEST 6 RELAY/SOLID STATE RELAY DRIVER OUTPUT TEST

Allows the operator to verify that the Relay and/or the Solid State Relay Driver output(s) are working. A volt/ohm meter will be required to test the output.

With tSt6 displayed, press and hold the DOWN key, then press the SCROLL key. oFF will be displayed. For SPST Relay outputs, connect the meter across the relay output in the ohm scale. The meter should read continuity with the relay on and infinity when the relay is off. For SSR Driver outputs, connect the meter across the output in the Volt DC scale. The meter should read 5 VDC when the SSR driver is on and 0 VDC when the driver is off. Press and release the DOWN key to advance through the following sequence:

Display	Relay On
rLYA	A Only
rLYb	B Only
rLYC	C Only
oFF	None

To exit, press the SCROLL key and tSt6 will be displayed. The existence of Relay and Solid State Relay Driver output(s) is dependent upon the hardware configuration.

5.3.7 TEST 7 CURRENT 1 OUTPUT TEST

This test allows the operator to verify that the current output(s) are functioning properly or will allow the selection of an output value for testing of associated equipment. A milliamp meter is required for testing.

With tSt7 displayed, press and hold the DOWN key, then press the SCROLL key. The display will indicate 4 milliamps. Use the UP and/or DOWN key to increase or decrease the current output in 1 mADC steps from 4 to 20mADC. The current output reading should be ± 0.5 mADC at any output value. To exit the test, press the SCROLL key and tSt7 will be displayed. **The existence of mADC current output is dependent upon the hardware configuration.** See Appendix A-3 (page 65 or 66) to make sure hardware is present.

5.3.8 TEST 8 CURRENT OUTPUT 2 TEST

This test is the same as Test 7 except that it is for Output 2.

5.3.9 TEST 9 AUXILIARY INPUT TEST

This test allows the operator to verify that the auxiliary inputs used for motor modulation feedback and remote Run/Hold contact closure are functioning properly. A variable voltage source, 5VDC, is required for testing.

With **tSt9** displayed, press and hold the **DOWN** key, then press the **SCROLL** key. The Auxiliary input voltage will be displayed to the nearest hundredth of a volt. Connect the +5V source across the Auxiliary input terminals (terminals 8 and 5) and adjust the supply up and down to verify that it changes on the display. The displayed voltage should typically be 0-5VDC +/- 0.3 volts. To terminate the test, press the **SCROLL** key. The display will show **tSt9**. Test 9 can be initiated again or another may be selected. The existence of the auxiliary inputs tested in Test 9 depends upon the hardware configuration.

5.3.10 TEST A COMMUNICATION HARDWARE TEST (Communications Option)

This test allows the operator to verify that the communications hardware is functioning properly.

With **tStA** displayed, press and hold the **DOWN** key then press the **SCROLL** key. The display will indicate **SEnd**. Each time the **DOWN** key is depressed, the unit will toggle between **SEnd** and **rEC** (receive). With the desired function selected, depress the **SCROLL** key. The unit will perform as described below.

In the **SEnd** (send or transmit) mode, the unit will repeat the following sequence. First it will enable the transmitter and put a logic 1 on the line for one second. Second, with the transmitter still enabled, it will change the logic level to 0 for one second. Third, it will disable the transmitter for one second. In the **rEC** mode, the unit will have its transmitter continuously disabled. In either mode, the unit will monitor the line and display **rEC1** or **rEC0** when it senses a logic 1 or 0 on the line respectively. In the **SEnd** mode, the unit will display **rEC** when the transmitter is disabled.

To perform an internal test and verify the basic operation of the hardware, place the unit in the **SEnd** mode and verify that the display cycles through **rEC1**, **rEC0** and **rEC**. To verify that the transmitter functions properly, two LED's, each with a current limiting resistor, can be connected to the communications terminals, with their polarities connected oppositely, and it should be observed that the following states are produced: one LED on, then the other LED on, then both off. Alternately, a load resistor can be placed on the terminals and it can be observed that the voltage generated across the load resistor is as follows : >+3 VDC, then >-3 VDC, and then 0 VDC.

Another method, which would also apply to an applications network, would be to connect one or more units in the Receive mode to a first unit in the Send mode. All of the units in the Receive mode should have their display alternating in sync with the first unit which is in the Send mode. When the sending unit displays **rEC**, the receiving units should display **rEC1**. To terminate the test, press the **SCROLL** key for one second. Upon exit, **tStA** will be displayed. Test A can now be initiated again or another test selected.

Trouble-shooting and Diagnostics 5.4

This section consists of two columns. The first column is a list of some possible instrument conditions. The second column is a list of steps that should improve the condition. The steps should be performed in order until the condition improves or all the steps have been completed. If the instrument condition has not improved, contact the nearest representative or factory for assistance.

Trouble-shooting should be performed by qualified personnel using the proper equipment and following all safety precautions. Whenever possible, the trouble-shooting should be accomplished with the electrical power disconnected. The instrument contains static sensitive components so care should be taken to observe anti-static procedures.

Condition

Correction Steps

Display is blank

1. Verify that the correct instrument power, as indicated on the wiring label on the housing, is supplied to terminals A & B. If the voltage is not correct, check the power source.
2. Turn off the instrument power. Wait about 5 seconds then turn the power on again.
3. Turn off the instrument power, loosen the front panel screw and remove the instrument from the housing. Inspect the instrument for poor connections.
 - a. The white ribbon cable that connects the Processor board (Appendix A-2, page 64) to the Power Supply Board (Appendix A-1, page 63), must be properly aligned and seated.
 - b. The Front Display board pins should be properly aligned and seated in the sockets on the Processor board (Appendix A-2, page 64) and the Power Supply board (Appendix A-1, page 63).
 - c. The EPROM and RAM chips, located on the Processor board (Appendix A-2, page 64) must be free from corrosion and firmly seated in the socket. Also check the Display Driver chip U1 located on the display board for the same. Reinsert the instrument in the housing, tighten the panel screw, and turn on the power.
4. Turn off the instrument power. Press and hold the UP and DOWN keys. Turn on the power. Hold the keys depressed for about 10 seconds. If the display lights the model number, Program , Tune and Profile mode parameters will need to be re-entered (pages 25 - 35, or the Software Ref. Sheet, pages 75-77, if already filled out).

Model Number Displayed is incorrect

1. Turn off the instrument power, wait 5 seconds then reapply power. Verify that the number displayed during the power up sequence is the same as indicated on the label affixed to the lower front of the display bezel.

2. Turn off the power to the instrument. Press and hold the UP and DOWN keys and turn on the power. Keep the keys depressed until the model number resets to **6100-000**. Release the keys and turn off the power.
3. To enter the correct model number press and hold the SCROLL and DOWN keys and turn on the instrument power, **6100** should be displayed. Wait about 5 seconds and release the SCROLL key first and then release the DOWN key. The display should remain **6100**. Use the UP/DOWN keys as necessary to change the displayed number to match the first 4 digits of the model number. After adjusting the first 4 digits to the proper values, press the SCROLL key and the display will change to **000-**. Use the UP/DOWN keys to set the last 3 digits of the model number to the correct values. Press the SCROLL key and the power up sequence will complete. The Program , Tune and Profile mode parameters will need to be re-entered (pages 25 - 35, or the Software Ref. Sheet, pages 75-77, if already filled out).

**Relay/SSR Driver Output(s)
Malfunction**

1. Verify that the Program and Tune mode parameters are correctly set (pages 25 - 32 or the Software Ref. Sheet, page 75, if already filled out).
2. Turn off the power to the instrument. Wait about 5 seconds and turn the power on again. Confirm that the model number displayed during the power up sequence indicates that the output(s) is/are present in the instrument. This number should match the number on the label affixed to the bottom of the front display bezel. If the model # is incorrect, follow the steps for "**Model # displayed is Incorrect**".
3. Turn off the power to the instrument. Loosen the front panel screw and remove the unit from the housing. Inspect the Power Supply board (Appendix A-1, page 63) for the presence of the output device(s). Relay A is located at K1, Relay B at K2, and Relay C at K3. A relay output will appear to be a cube. The SSR Driver will appear as a resistor and a jumper wire. The output will not work if the hardware is not present.
4. Check the output operation by performing Test 6 as described in the Test section (page 54). If the output(s) function(s) in the Test mode, re-examine the Program and Tune mode parameter settings (pages 25- 32, or the Software Ref. Sheet, page 75, if already filled out).
5. If the output appears not to turn off, remove the power to the instrument. Loosen the front panel screw and take the unit out of the housing. Clip the resistor located on the Power Supply board (Appendix A-1, page 63) for the output(s) that seem to stay on. A .01 microfarad, 1 KV should be connected from the terminal listed below, for the output where the resistor indicated was removed, to the AC ground.

(Continued on next page)

(Continued from page 57)

Relay A	R12	Terminal C
Relay B	R13	Terminal E
Relay C	R14	Terminal G

Return the instrument to the case and tighten the front panel screw. Turn the power on to the instrument and check the operation of the output(s).

**mADC Output(s)
Malfunction**

1. Verify that the Program and Tune mode parameters are correctly set (page 25 & 32 or the Software Ref. Sheet, page 75, if already filled out).
2. Turn off the power to the instrument. Wait about 5 seconds and turn the power on again. Confirm that the model number displayed during the power up sequence indicates that the output is present in the instrument. The number should match the model number on the label located on the bottom of the front display bezel. If the model # is incorrect, follow the steps for "Model # displayed is incorrect" (page 57).
3. Verify that the hardware is present on the Option board (Appendix A-3, page 65 or 66).
4. Check the output operation in the Test mode. Use Test 7 for Output 1 and Test 8 for Output 2. If the output works in the Test mode, re-check the Program & Tune mode parameter settings (pages 25 - 32, or the Software Ref. Sheet, page 75, if already filled out).

Error Code Displayed

**SnSr
Sensor Break or out of range**

1. Inspect the sensor for proper operation and connection to the instrument. Acceptable sensor ranges for the instrument are listed in the Specifications section of Appendix D (page 71).
2. Verify that the Program mode input selection matches the sensor input connected.
3. Check that the input conditioning jumpers on the Processor board (Appendix A-2, page 64) and the Option Board (Appendix A-3, page 65 or 66) are in the proper position for the sensor input.
4. Perform the calibration procedure(s), as described in the Calibration section (page 47) for the sensor input type.

**FbEr
Slidewire Feedback Error**

1. Inspect the Slidewire Feedback connections at terminals 8, 7 and 5. Be sure that the connections are the same as shown in the position proportioning illustration (page 20).

2. Measure the resistance of the Slidewire segment. The minimum resistance must be 135 ohms, the maximum 10 K ohms.
3. Perform the Auxiliary Input Test, Test 9 as described in the Test section (page 55). The voltage indicated should be between 0 and 5 VDC.
4. Turn off the power to the instrument. Loosen the front panel screw and take the instrument out of the housing. Verify that the jumper JU-1 on the Option board (Appendix A-3, page 65) is in the Motor Modulation position.

HI - Input more than 10% Over Span

1. Perform the steps listed for the **SnSr** error condition (page 58).

Lo - Input more than 10% Under Span

1. Perform the steps listed for the **SnSr** error condition (page 58).

6 - display overranged (the "broken 6" appears on the left side of the display)

1. If this error code is displayed as a Program or Tune mode parameter value, perform CAL1 procedure as described in the Calibration section (page 48).
2. If this error code appears as part of the model number during the power up sequence, follow the steps listed for the "**Model # Is Incorrect**" condition (page 57).
3. If this error appears in the process reading and **dPoS** equals 1, then it means the process is greater than 999.9.

Er1 - Microprocessor RAM Failure

1. Turn off the power to the instrument.
2. Loosen the front panel screw and remove the instrument from the housing. Inspect that the microprocessor (U1) is properly seated in the socket located on the Processor board (Appendix A-2, page 64). Return the instrument to the housing and tighten the front panel screw. Turn the power on.

Er2 - External RAM Failure

1. Turn off the power to the instrument. Wait 5 seconds and turn the power on.

Er3 - EPROM Checksum Failure

1. Perform the steps listed for Er1 except that the EPROM (U2) on the Processor board (Appendix A-2, page 64) should be inspected.

Er4 - RTD Mismatch Error

1. Check the connections to the instrument for the RTD Input Calibration procedure (page 50). Repeat the RTD Input Calibration.

Er5 - No Zero Crossings Detected

1. Turn off the power to the instrument. Wait 5 seconds and turn the power on.
2. Turn off the power to the instrument. Loosen the front panel screw and remove the instrument from the housing. Inspect the white ribbon cable that connects the Processor board to the Power Supply board. Be sure that the cable is properly aligned and seated in the socket on the Power Supply board. Return the instrument to the housing and tighten the front panel screw. Turn the power on to the instrument.
3. Connect the instrument to another AC power source.

Er6 - AC line below 45 HZ

1. Turn off the power to the instrument. Wait 5 seconds and turn the power on.
2. Turn off the power to the instrument. Loosen the front panel screw and remove the instrument from the housing. Inspect the white ribbon cable that connects the Processor board to the Power Supply board. Be sure that the cable is properly aligned and seated in the socket on the Power Supply board. Return the instrument to the housing and tighten the front panel screw. Turn on the power to the instrument.
3. Connect the instrument to another AC power source.

Er7 - AC line over 65 HZ

1. Turn off the power to the instrument. Wait 5 seconds and turn the power on.
2. Turn off the instrument power. Loosen the front panel screw and remove the instrument from the housing. Inspect the white ribbon cable that connects the Processor board to the Power Supply board. Be sure that the cable is properly aligned and seated in the socket on the Power Supply board.
3. Connect the instrument to another AC power source.

Er8 - Cal 2 Volt Input Error

1. Check that 50 mVDC is properly connected to the instrument and is within the tolerance limits as indicated in the CAL2 procedure of the Calibration section (page 48).
2. Loosen the front panel screw and remove the instrument from the housing. Inspect the Processor board (Appendix A-2, page 64) to insure that the input conditioning jumper JU1 is in the non-volt position.
3. Perform the CAL2 procedure as described in the Calibration section (page 48).

Er9 - ADC Reference Number Error

1. Perform the CAL2 procedure as described in the Calibration section (page 48).

Er10 - ADC Reference Voltage Error

1. Perform the CAL2 procedure as described in the Calibration section (page 48).

Er11 - Cold Junction Compensation Error

1. Be sure the Cold Junction Sensor is firmly attached to terminals 2 and 4.
2. Perform the CAL3 procedure as described in the Calibration section (page 49).

Er12 - CAL2 Voltage Error

1. Check that 50mVDC is properly connected to the instrument and is within the tolerance limits as indicated in the CAL2 procedure of the Calibration section (page 48).
2. Loosen the front panel screw and remove the instrument from the housing. Inspect the Processor board (Appendix A-2, page 64) to insure that the input conditioning jumper JU1 is in the non-volt position.
3. Perform the CAL2 procedure as described in the Calibration section (page 48)

Er13 - RTD CAL5 Input Error

1. Check that the resistance device is of the correct value and properly connected to the instrument and is within the tolerance limits as indicated in the CAL5 procedure of the Calibration section (page 50).
2. Loosen the front panel screw and remove the instrument from the housing. Inspect the Processor board (Appendix A-2, page 64) to insure that the input conditioning jumper JU1 is in the non-volt position and that the Option board jumpers (Appendix A-3, page 65) JU2 and JU3 are in the RTD position.
3. Perform the CAL 5 procedure as described in the Calibration section (page 50).

Er14 - Cold Junction Compensation Error

1. Be sure the Cold Junction Sensor is firmly attached to terminals 2 and 4.
2. Perform the CAL3 procedure as described in the Calibration section (page 49).

Er15 - Ground Reference Tolerance Error

1. Perform the CAL2 procedure as described in the Calibration section (page 48).

Er16 - Program/Tune Mode Checksum Error

1. Record all Program and Tune mode parameters. Perform the CAL1 procedure as described in the Calibration section (page 48). Re-enter the Program and Tune mode parameters.

Er17 - Calibration Checksum Error

1. Perform the calibration procedures that are needed for the input sensors that will be used (page 48).

Er18 - Profile Data Checksum Error	1. Record all Profile data that was entered. Perform the CAL8 procedure as described in the Calibration section (page 51). Re-enter the Profile data as needed.
Er19 - Tried to run profile with 0 segments	1. Press the RUN/HOLD key, then press and release the SCROLL key until oFF or Ctrl are displayed, then press the DOWN key. This error occurs if a profile number is selected in a Profile Continue mode for a profile that has not been developed.
Er20 - Setpoint Error	<ol style="list-style-type: none"> 1. Use the UP or DOWN key to change the setpoint value. 2. Record all Program and Tune mode parameters. Perform the CAL1 procedure as described in the Calibration section (page 48). Re-enter the Program and Tune mode parameters.
Er36 - Incorrect Crystal For Digital Comm.	<ol style="list-style-type: none"> 1. Turn off the power to the instrument, wait 5 seconds then turn the power on. 2. Check the crystal for 11 MHZ Y1 (see Appendix A-2, page 64)
Er37 - Incorrect Micro. For Digital Comm.	<ol style="list-style-type: none"> 1. Turn off the power to the instrument, wait 5 seconds then turn the power on. 2. Check to make sure U1 is a 8032 (see Appendix A-2, page 64)
Errors 70 through 73 are communication errors that are briefly displayed when they occur.	
Er70 - The Controller was unable to respond within 250 milliseconds	When the unit receives a complete message, the controller has 250 milliseconds to respond to the request. If for any reason the controller is unable to respond within 250 milliseconds, the error is posted and the request ignored.
Er71 - A byte was received by the controller before the response was transmitted	While the unit is processing a message, no data should be on the communication link until the unit has responded. If the unit receives data before a response is transmitted, the error is posted and the message aborted.
Er72 - An incorrect Block Check character was received	After the complete message has been received, if the Block Check Character (BBC) transmitted does not match the calculated BCC, the error is posted and the unit will send a Negative Acknowledge (NAK).
Er73 - A byte was received with incorrect parity	If incoming data has incorrect Parity, the unit will post the error and ignore the rest of the message. The number of ones in the transmitted byte is expected to be even (Even Parity).

Appendix A

Board Layout - Jumper Positioning

FIGURE A-1 - Power Supply Board

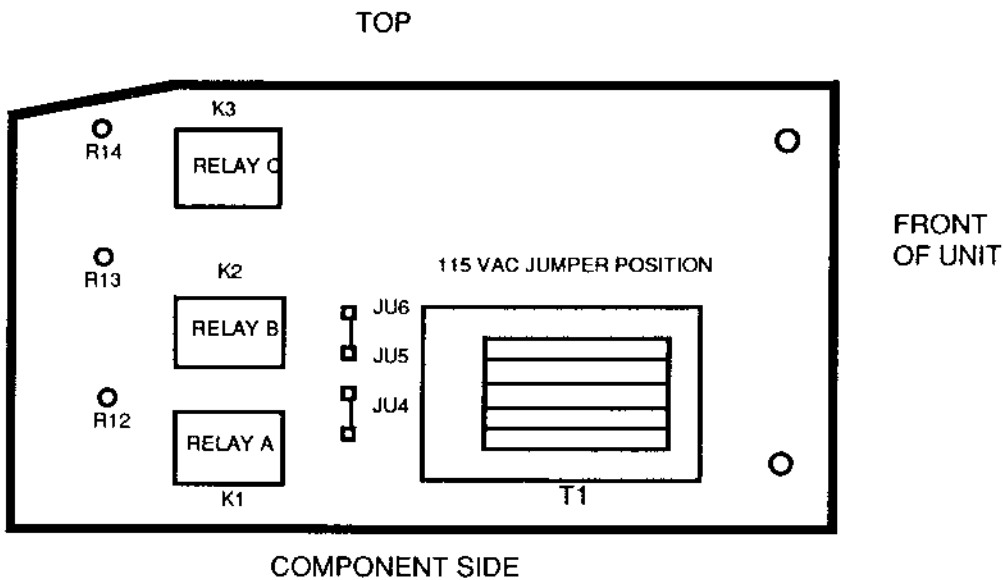

230 VAC UNITS MAY BE FIELD CONVERTED TO 115 VAC BY MOVING JUMPERS AS SHOWN ABOVE .
 (115 VAC UNITS CANNOT BE FIELD CONVERTED TO 230 VAC!!)

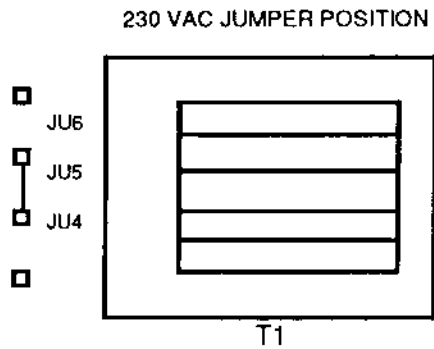

FIGURE A-2 - Processor Board

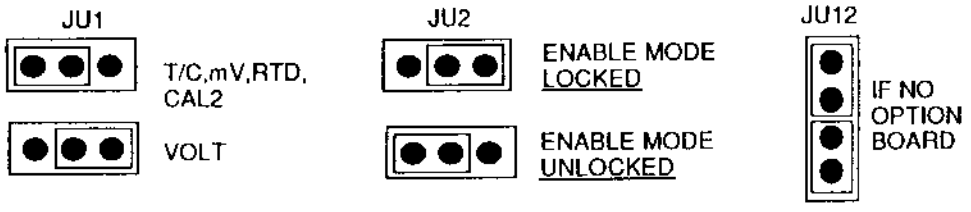
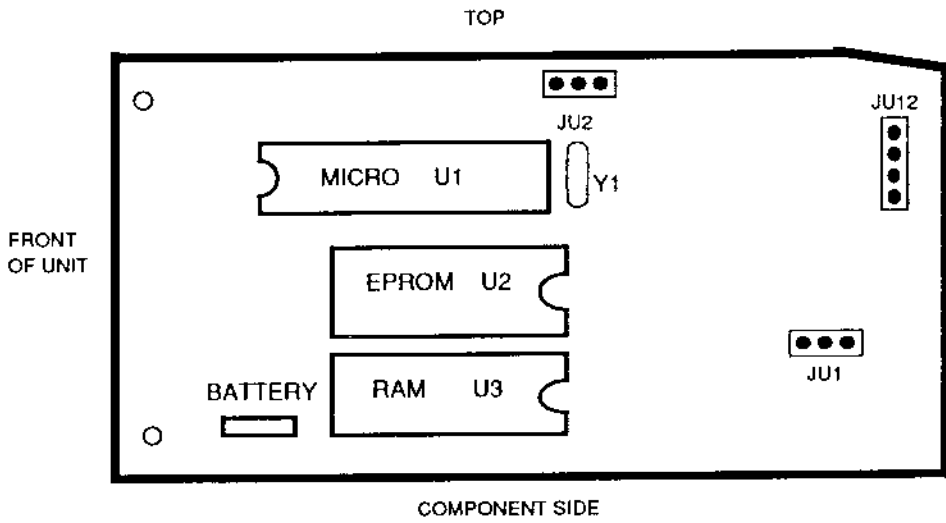
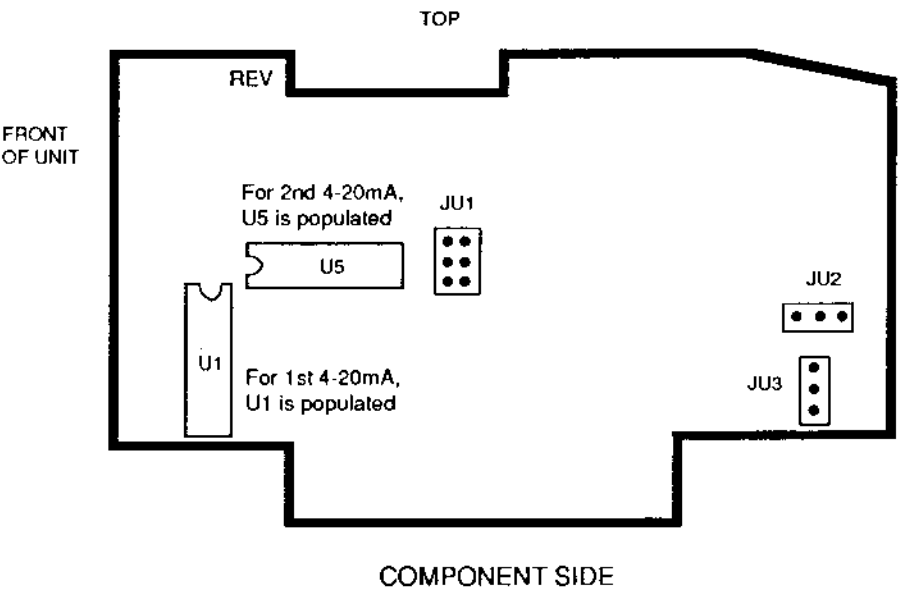





FIGURE A-3 - Option Board - Revision D and below



- JU1**
 2ND 4-20 mADC
-  MOTOR MODULATION/
POSITION PROPORTIONING
POTENTIOMETER REMOTE
SETPOINT
-  DIGITAL
COMMUNICATIONS
422/485





- JU2**
 RTD

- JU3** T/C, mV, VOLT (NON-RTD)
 RTD
 T/C, mV, VOLT (NON-RTD)

FIGURE A-3 - Option Board - Revision E and above

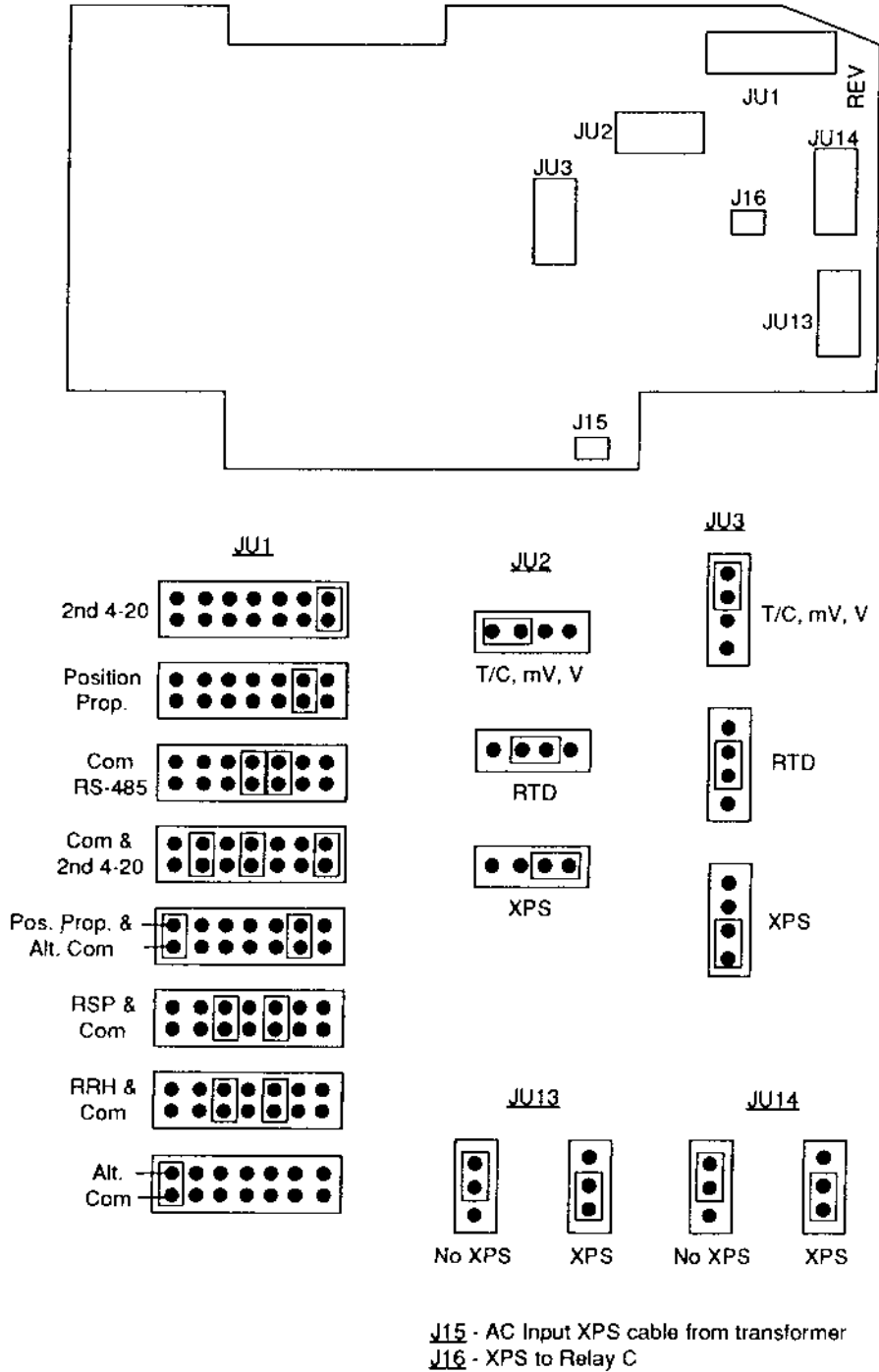

Appendix B

Glossary

Assured Soak

Assured Soak refers to the ability of the instrument to be programmed to interrupt the Soak segment time down if the process value exceeds a deviation value selected in the Profile Entry mode from the setpoint. The Soak timer will restart from where it was stopped when the process value does not exceed the deviation value selected from setpoint.

Automatic Reset (Integral)

This parameter is used so that the instrument will compensate for process variable deviations from setpoint that occur when the process load characteristics change. Instructions for determining the automatic reset settings are given in Section 4.3 (page 44). Factory default is 0.0. Display code **ArSt**.

Automatic Transfer

This feature, if configured, allows manual control of the process until setpoint is reached, at which point the controller automatically transfers from manual to automatic control. Factory default value is 0 = no auto transfer. Display code **AtFr**.

Balanceless Transfer

This feature prevents changes in proportional output when changing from the Manual to Control mode of operation. When transferring from the manual mode to the control mode, the proportional outputs will be "Balanceless" regardless of whether the unit is inside or outside the proportional band. This only holds true if the Auto Reset (ArSt) value is greater than 0.

Bumpless Transfer

This feature prevents step changes in proportional outputs when changing from *automatic* to *manual control only*.

Control Algorithm

A pre-programmed series of instructions that are used by the instrument when determining the status of the output(s).

Cycle Time

This Tune mode parameter is used to select the on/off cycle time for time proportioning outputs (Ct1 for Output 1 and/or Ct2 for Output 2).

When using the Position Proportioning option, Ct1 must be selected for the stroke time of the motor.

Display Filter Factor

This parameter is adjustable from 1 to 20 which represents the number of scans of the process variable that are averaged together before updating the displayed value. The factory default value is 1 = no filtering. Display code **dFF**.

Engineering Units Upper and

Engineering Units Lower

These Program mode parameters are used with volt, millivolt, and milliamp inputs. The Engineering Units Upper **Euu** should be selected as the value to be displayed when the input is at maximum. The Engineering Units Lower **EuL** should be selected as the value to be displayed when the input is at minimum.

First Output Position

This parameter is adjustable from -1000 to 1000 units and represents a shift or offset of the on-off actuation points or proportional band for the first output relative to the normal position. For example, a negative value could be used to offset an expected overshoot. First Output Position also shifts the proportional band with respect to the process value range outside of which integral action is inhibited. Factory default is 0. Display code **FoP**.

Hysteresis

This parameter is adjustable from 0 to 300 units representing the width of the band (half above and half below setpoint). Used with On-Off or Alarm outputs to reduce cycling. For instance, with a value of 4 and a setpoint of 70, the output will turn On when the process variable drops to 68 and stay On until 72 is reached, then turn Off the output. Factory default is 3. Display code is **HySt**.

Input Correction

This parameter is used to adjust the process variable value to compensate for sensor errors. This Program mode parameter is selectable from -300 to +300 degrees/units. The factory default is 0. Display code is **iCor**.

Manual Reset

This parameter is adjustable from -1500 to 1500 units representing a manual shift of proportional band(s) relative to the normal position. Manual reset is intended to be used when automatic reset is not used to allow compensation for deviations from setpoint which remain after the process has stabilized. Factory default is 0. Increasing the value increases the process variable, i.e. if the process variable stabilized too low, increase the manual set, Integral action, and conversely reset-windup inhibit apply over the same process value range regardless of the manual reset value. Display code **rSET**.

Position Proportioning Sensitivity

A percentage of the first output proportional band width (**Pb1**).

Process Filter Factor

This Program mode parameter is used to dampen the process value used to calculate output action. The process value is averaged to dampen the control outputs. This parameter is adjustable from 1 to 20. Factory default is 1. Display code **PFF**.

Process Retransmission Output (EO Software Option)

Allows retransmission of the process variable. Factory default is 0 = not selected. Display code **Pout**. If selected, must be assigned to a current output and scaled using Process/Setpoint upper and lower values.

Process/Setpoint Output Upper and Lower Values (Used in conjunction with process or setpoint retransmission output)

These parameters specify the process or setpoint value range over which the assigned current output will vary in a linear manner from 100 % to 0 %. If the process value or setpoint is greater than **Pou** the output will be 100%. If the process or setpoint value is less than **PoL** the output will be 0%. Factory default values are 2000 for the upper value and 0 for the lower value. Display codes **Pou** (upper) and **PoL** (lower).

Process Variable

The process variable refers to the condition of the process being measured (sensed). The instrument will accept process inputs other than temperature (pressure, level, flow, etc.).

Proportional Band (PB)

This Tune mode parameter selects the span of the proportional output range. This parameter is adjustable from 1 to 3000 degrees/units. Factory default is 100. If Output 1 is selected as a proportional output, a display code of **Pb1** will be seen. If Output 2 is selected as a proportional output, the display code will be **Pb2**.

Ramp

A Ramp is the section of profile segment where the setpoint value is being changed from the initial value to the value selected over the time period selected. The first Ramp of a profile will take the process value at the time the profile was started as the initial setpoint value.

Rate (Derivative)

This parameter is adjustable from 0.0 to 10.0 minutes and specifies how the control action responds to the rate of change in the process variable. For example, if the process variable is rising rapidly to setpoint, power is turned off sooner than it would be if the rise were slow. In effect, derivative action anticipates lags within the system and shifts the proportioning band by an amount determined by the rate of change of the input sensor. Magnitude of the shift is determined by a derivative time constant. If the time constant is, say, .1 minute (6 seconds), for every unit per second rate of change of the process variable at the sensor, the proportioning band is moved 7 units in the direction that helps control. Likewise, if the time constant is 1 minute (60 seconds), for every unit per second rate of change of the process variable at the sensor, the proportioning band is moved 60 units in the direction that helps control. Instructions for determining rate is given in Section 4.3 (page 44). Factory is 0.0. Display code **rAtE**.

Rate of Change (EO Software Option)

This parameter is used to provide ramp changes based upon a selectable rate of change. Degrees per hours, minutes, seconds.

Second Output Position

This parameter is adjustable from -1000 to 1000 units and represents a shift or offset of the on-off actuation points or proportional band for the second output relative to the normal position. A positive value creates a gap where no control outputs are on, a negative value creates an overlap of control outputs (if the first output position is at the normal position). Second Output Position also shifts the proportional band with respect to the process value range outside of which integral action is highlighted (reset-windup inhibit). Factory default is 0. Display code **Sprd**.

Segment

A segment refers to a part of a profile. A segment consists of a Ramp and a Soak section.

Setpoint Re-Transmission Output (EO Software Option)

Allows for re-transmission of the setpoint value. Factory default is 0 = not selected. Display code **Pout**. If selected, must be assigned to a current output and scaled using Process/Setpoint upper and lower values.

Soak

A Soak is the section of a profile segment where the setpoint value is at a constant value for the time period selected.

Appendix C - Order Matrix

6	W
<p>Input</p> <ul style="list-style-type: none"> 1 T/C or mV 2 Volts/mA 3 RTD 4 All Inputs 	
<p>Output Group 1 Control Output 1 and/or Event</p> <ul style="list-style-type: none"> 1 Relay 2 SSR Driver 3 4-20 mA & Relay 4 4-20 mA & SSR Driver 	
<p>Output Group 2 Control Output 2 and/or Event</p> <ul style="list-style-type: none"> 0 None 1 Relay 2 SSR Driver 3 4-20 mA 4 4-20 mA & Relay 5 4-20 mA & SSR Driver 	
<p>Output Group 3/Alarm or Event</p> <ul style="list-style-type: none"> 0 None 1 Relay 2 SSR Driver 	
<p>Remote</p> <ul style="list-style-type: none"> 0 None 1 Position Proportioning* 2 Remote Run/Hold 3 RS-485 Std. Com.** 4 RS-485 Std. Com.*** 5 RS-485 Total Access Com.** 6 RS-485 Total Access Com.*** 	
<p>Voltage</p> <ul style="list-style-type: none"> 1 115VAC Input & Relays 2 230VAC Input & Relays 3 115VAC Input & 230VAC Relays 	
<p>Option Suffix</p> <ul style="list-style-type: none"> (Blank) None EO Extended Features Software Option XP 24VDC Transmitter Power Supply XA 24VDC Power Supply*** 	
<p>Application Suffix</p> <ul style="list-style-type: none"> W Standard package with NEMA 4 type enclosure 	

* Output Group 2 cannot be 0 or 3.

** Cannot be included when Output Group 2 selections 3, 4, or 5.

*** Cannot be included when Output Group 3 selection is 1 or 2.

Appendix D

Product Specifications

Measurement Error Limit	<ul style="list-style-type: none">• Type J, K, T, E, N, C, T/C's and RTD +/- .25% of reading plus 1 degree @ 25 degrees C• Type R, S, B T/C's ± .25% of span @ 25 degrees C• mA, mV and VDC ± .25% of scaled span plus 1 Least Significant Digit @ 25 degrees C
Ambient Temperature Error	0.01% of span per degree C deviation from 25 degrees C
Scan Rate	1 scan/second
Display Resolution	0 to 3 decimal places (depending upon input type selected)
Noise Rejection	Normal mode, 85 dB minimum at 60 Hz or greater. Common mode, 90 dB minimum, 115 VAC maximum.
Line Voltage	115/230 VAC ± 10% 50/60 Hz
Power Consumption	15VA maximum
Operating Temperature	0 to 55° C 32 to 131° F
Storage Temperature	-40 to 65° C -40 to 149° F
Humidity	0 to 90% RH, non condensing
Dimensions	1/4 DIN front panel (96mm x 96mm) and 5.8 inches deep
Weight	3 pounds maximum
Vibration	0.5 to 100 Hz @ 0.5g
Agency Approvals	UL and CSA pending
Warranty	3 years, see inside back page.

THERMOCOUPLE

TYPE	RANGE	TYPE	RANGE
J	-130 to 760°C -200 to 1400°F	E	0 to 750°C 0 to 1400°F
K	-130 to 1370°C -200 to 2500°F	B	200 to 1800°C 400 to 3300°F
T	-200 to 400°C -330 to 750°F	N	0 to 1300°C 0 to 2370°F
R	200 to 1650°C 400 to 3000°F	C	200 to 2300°C 390 to 4170°F
S	200 to 1650°C 400 to 3000°F		

RTD	VOLTS	MILLIVOLTS
100 OHM	0 to 5VDC	0 to 25mVDC
-140 to 440°C	1 to 5VDC	0 to 50mVDC
-220 to 750°F		10 to 50mVDC
		0 to 25mVDC

MILLIAMPS

4-20mA input is accommodated via 10-50mV or 1-5V with the addition of the appropriate external shunt resistor

SENSOR FAULT DETECTION

Displays HI or Lo process input for thermocouple or RTD inputs (10% above or below range) and sensor break, SnSr. On/Off outputs and events go off, proportional outputs go to 0% output. Sensor fault detection is not functional for 0 to 5 VDC.

CONTROL ADJUSTMENTS

On/Off Hysteresis	0 to 300 units
Proportional Band	1 to 3000 units
Manual Reset	-1500 to 1500 units
Auto Reset	0.0 to 100 repeats/min.
Rate	0.0 to 10.0 min.
Cycle Time	1 to 240 sec.
Position Proportioning Sensitivity	0.0 to 50.0%
First Output Position	-1000 to 1000 units
Spread (Second Output Position)	-1000 to 1000 units

ALARM ADJUSTMENTS

Process Alarm	-9999 to 9999 units
Deviation Alarm	-3000 to 3000 units
Deviation Band Alarm	1 to 3000 units

CONTROL OUTPUTS

Relay	SPST 115VAC: 5.0A Resistive; 1/8HP or 250VA 230VAC: 2.5A Resistive; 1/8HP or 250VA
SSR Driver	Open collector output Short circuit protected @ 100mA maximum. 4VDC at 20mA or 3VDC at 40mA.
Current	4-20mADC into 650 ohms maximum

ALARM OUTPUT

Relay	SPST 115VAC: 5.0A Resistive; 1/8HP or 250VA 230VAC: 2.5A Resistive; 1/8HP or 250VA
SSR Driver	Open collector output Short circuit protected @ 100mA maximum 4VDC at 20mA or 3VDC at 40mA

DISPLAY

Digital Display	Four (4) .56 inch high, 7 segment LED's
Status Indicators	LED indicators for Setpoint, Output 1, Output 2, Manual, Alarm, Degrees C, Degrees F, U (engineering units), Seg1 thru Seg 6, Ramp and Soak

DIGITAL COMMUNICATIONS

Type	RS-485 serial communications port. Half duplex bi-directional communications
Character Format	ASCII
Protocol	Per ANSI X3.28 subcategories 2.5 and A4
Configuration	User configurable to Monitor (read only) or Normal (read and write)
Bit Rate	User configurable to 300, 600, 1200, 2400, 4800, or 9600 bits per second
Address	User configurable 0 to 99

PROFILE PARAMETERS	
Programmable Profiles	8 user programmable profiles
Segments	1 to 6 segments per profile
Ramp and Soak	1 ramp and soak per segment
Profile Time Base	Selectable: HHH.T (hours and tenths) HH.MM (hours and minutes) MM.SS (minutes and seconds) EO Option: Units per hour ramp rate, HHH.T soak time Units per hour ramp rate, HH.MM soak time Units per minute ramp rate, MM.SS soak time
Profile Interrupt Action	Upon return of AC power either: Go to OFF mode Continue profile Go into HOLD Restart profile at beginning
Profile Loop Count	1 to 9999, 0=continuous
Profile End Control	Selectable: Hold at last setpoint Abort (all outputs off or 0%) Transfer to another profile
Assured Soak	Deviation Hold after Ramp Up; 1 to 3000 units, 0=no auto hold Deviation Hold after Ramp Down; 1 to 3000 units, 0=no auto hold
Remote Run/Hold	Selectable: Override RUN/HOLD key Allow RUN/HOLD key to function
Event Outputs	3 possible event outputs. Each event can be set on or off for each ramp and soak.

Appendix E Software Reference/Record Sheet

		PROGRAM MODE		TUNE MODE	
Standard Software		InPs		SPrd	
		Icor		PAL	
		out 1		dAL	
		o1PL		dbAL	
		out 2		Pb 1	
		o2PL		Pb 2	
		out 3		rSET	
		rLyA		ArSt	
		rLyb		rAtE	
		rLyC		Ct 1	
		dISP		Ct 2	
		dPOS		SEns	
		Euu		FoP	
		EuL			
	HySt				
	SPL				
EO		SPuL		ENABLE MODE	
		SPLL		ENAB	ON
EO		AtFr		EtSt	
		Ptb		ECAL	
		PIA		EPro	
		rrH		Etun	
		PFF		ESby	
		dFF		EPC	
EO		Co1r		EPE	
		Co2r		ESPC	
		Pout			
		Pou			
		PoL			
Comm		CCon			
		Cbs			
		CAd			

Pn						
nS						
Seg	1	2	3	4	5	6
rt						
rr						
SP						
E1						
E2						
E3						
St						
E1						
E2						
E3						
PLCt						
dhru						
dhrd						
PEnd						

Pn						
nS						
Seg	1	2	3	4	5	6
rt						
rr						
SP						
E1						
E2						
E3						
St						
E1						
E2						
E3						
PLCt						
dhru						
dhrd						
PEnd						

Pn						
nS						
Seg	1	2	3	4	5	6
rt						
rr						
SP						
E1						
E2						
E3						
St						
E1						
E2						
E3						
PLCt						
dhru						
dhrd						
PEnd						

Pn						
nS						
Seg	1	2	3	4	5	6
rt						
rr						
SP						
E1						
E2						
E3						
St						
E1						
E2						
E3						
PLCt						
dhru						
dhrd						
PEnd						

Pn						
nS						
Seg	1	2	3	4	5	6
rt						
rr						
SP						
E1						
E2						
E3						
St						
E1						
E2						
E3						
PLCt						
dhru						
dhrd						
PEnd						

Pn						
nS						
Seg	1	2	3	4	5	6
rt						
rr						
SP						
E1						
E2						
E3						
St						
E1						
E2						
E3						
PLCt						
dhru						
dhrd						
PEnd						

Pn						
nS						
Seg	1	2	3	4	5	6
rt						
rr						
SP						
E1						
E2						
E3						
St						
E1						
E2						
E3						
PLCt						
dhru						
dhrd						
PEnd						

Pn						
nS						
Seg	1	2	3	4	5	6
rt						
rr						
SP						
E1						
E2						
E3						
St						
E1						
E2						
E3						
PLCt						
dhru						
dhrd						
PEnd						

Appendix F Profile Development Sheet

The Profile Development Worksheet is intended to assist the Profile Controller customers. By filling in the worksheet with the application requirements, profile information can easily be obtained for entry into the instrument. The worksheet is a convenient record of the profile for future use.

A profile is a programmed sequence of setpoint changes over a period of time (or at a rate of change with the EO option) (**Ramp**) and a constant setpoint (**Soak**). A sequence of a ramp and a soak is referred to as a **Segment**. A profile can contain from 1 to 6 segments. The instrument can store in memory up to 8 profiles.

The profile controllers can provide timed output relay action while running a profile, this is called an **Event**. Events may be selected as on or off as needed during each Ramp and/or Soak segment of the profile.

The first step to completing the worksheet is to determine the range of the setpoints necessary for the application. Fill out the setpoint scale along the left side of the worksheet. Remember that the profile ramp will start at the process value indicated when the profile is initiated.

The next step is to sketch the profile outline on the worksheet. Use the setpoint scale to determine the setpoint level. Be sure to fill in the time periods for each part of the segment in the boxes provided at the top of each column. The **Ramp** and **Soak** time boxes are located at the top of each column below the setpoint box for the segment. There are boxes at the bottom of each column to indicate the status of events, if used. If more than six segments are needed for the profile, individual profiles can be linked to perform sequentially. Linked profiles operate like one long profile.

Profile program information is easily determined by completing the Profile Developmental Worksheet (page 78) for the application. The information derived within the worksheet is directly related to the profile entry parameters of the profile controller.

Profile Worksheet

Profile Number ..
 Number of Segments ..

Segments	1		2		3		4		5		6	
	SP		SP		SP		SP		SP		SP	
	Ramp Time	Soak Time	Ramp Time	Soak Time	Ramp Time	Soak Time	Ramp Time	Soak Time	Ramp Time	Soak Time	Ramp Time	Soak Time
Setpoint Scale												
Event 1												
Event 2												
Event 3												

Profile End Action _____
 Profile Loop Count _____
 Deviation Hold After Ramp Up _____
 Deviation Hold After Ramp Down _____
 Profile Time Base _____
 Profile Interrupt Action _____

Sample Profile

The following is a sample profile intended to assist in understanding how the profile controller functions. Be sure to disconnect all control outputs before running this profile.

Press and release the SCROLL key until **Prog** appears on the display then press the DOWN key. Press and release the DOWN key until **diSp** appears then press the SCROLL key. Press and hold the UP key until the display shows a 5 then press the SCROLL key. Press and release the Down key until **Ptb** appears then press the SCROLL key. Press and hold the UP key until a 3 appears then press the SCROLL key. Press the UP key and **Prog** will appear. Press and release the SCROLL key until **PEnt** appears then press the DOWN key. Perform the following keystrokes:

<u>Display</u>	<u>Keystroke</u>		
Pn	SCROLL	St	SCROLL
X	DOWN	X	UP/DOWN
1	SCROLL	0.10	SCROLL
nS	SCROLL	rt	SCROLL
X	UP	X	UPDOWN
6	SCROLL	0.10	SCROLL
rt	SCROLL	SP	SCROLL
X	UP/DOWN	X	UP/DOWN
0.10	SCROLL	50	SCROLL
SP	SCROLL	St	SCROLL
X	UP/Down	X	UP/DOWN
100	SCROLL	0.10	SCROLL
St	SCROLL	PLct	SCROLL
X	UP/DOWN	X	UP/DOWN
0.10	SCROLL	2	SCROLL
rt	SCROLL	dhru	SCROLL
X	UP/DOWN	X	UP/DOWN
0.10	SCROLL	0	SCROLL
SP	SCROLL	dhrd	SCROLL
X	UP/DOWN	X	UP/DOWN
150	SCROLL	0	SCROLL
St	SCROLL	PEnd	SCROLL
X	UP/DOWN	X	UP/DOWN
rt	SCROLL	0	SCROLL
X	UP/DOWN	Pn	UP
0.10	SCROLL	PEnt	
SP	SCROLL		
X	UP/DOWN		
300	SCROLL		
St	SCROLL		
X	UP/DOWN		
0.10	SCROLL		
rt	SCROLL		
X	UP/DOWN		
0.10	SCROLL		
SP	SCROLL		
X	UP/DOWN		
200	SCROLL		
St	SCROLL		
X	UP/DOWN		
0.10	SCROLL		
rt	SCROLL		
X	UP/DOWN		
0.10	SCROLL		
SP	SCROLL		
X	UP/DOWN		
100	SCROLL		

With **PEnt** on the display, press and release the SCROLL key until **P 1** appears in the display then press RUN/ HOLD key. The display will show **run**, then display the ramping setpoint of the profile. This is to demonstrate how the profile controller functions.

Warranty and Return Statement

These products are sold by The Anderson Instrument Company (Anderson) under the warranties set forth in the following paragraphs. Such warranties are extended only with respect to a purchase of these products, as new merchandise, directly from Anderson or from an Anderson distributor, representative or reseller, and are extended only to the first buyer thereof who purchases them other than for the purpose of resale.

Warranty

These products are warranted to be free from functional defects in materials and workmanship at the time the products leave the Anderson factory and to conform at that time to the specifications set forth in the relevant Anderson instruction manual or manuals, sheet or sheets, for such products for a period of three years.

THERE ARE NO EXPRESSED OR IMPLIED WARRANTIES WHICH EXTEND BEYOND THE WARRANTIES HEREIN AND ABOVE SET FORTH. ANDERSON MAKES NO WARRANTY OF MERCHANTABILITY OR FITNESS FOR A PARTICULAR PURPOSE WITH RESPECT TO THE PRODUCTS.

Limitations

Anderson shall not be liable for any incidental damages, consequential damages, special damages, or any other damages, costs or expenses excepting only the cost or expense of repair or replacement as described above.

Products must be installed and maintained in accordance with Anderson instructions. Users are responsible for the suitability of the products to their application. There is no warranty against damage resulting from corrosion, misapplication, improper specifications or other operating condition beyond our control. Claims against carriers for damage in transit must be filed by the buyer.

This warranty is void if the purchaser uses non-factory approved replacement parts and supplies or if the purchaser attempts to repair the product themselves or through a third party without Anderson authorization.

Returns

Anderson's sole and exclusive obligation and buyer's sole and exclusive remedy under the above warranty is limited to repairing or replacing (at Anderson's option), free of charge, the products which are reported in writing to Anderson at its main office indicated below.

Anderson is to be advised of return requests during normal business hours and such returns are to include a statement of the observed deficiency. The buyer shall pre-pay shipping charges for products returned and Anderson or its representative shall pay for the return of the products to the buyer.

Approved returns should be sent to:

**ANDERSON INSTRUMENT COMPANY INC.
156 AURIESVILLE ROAD
FULTONVILLE, NY 12072 USA**

ATT: REPAIR DEPARTMENT



ANDERSON INSTRUMENT CO.
156 AURIESVILLE RD.
FULTONVILLE, NY 12072 USA
800-833-0081 • FAX 518-922-8997
LATIN AMERICA AND ASIA
Maida International
516-676-3079 • FAX 516-676-3199
www.andersoninstrumentco.com