

Pressure Relief Valve



Pressure Relief Valve with adjustable opening pressure

To achieve the desired relief pressure, the spring is pre-loaded by adjusting an easily accessible screw on top of the actuator. Each valve size has several spring ranges available as standard.

Challenge

High viscosity fluids and long pipe runs require high pressures. Positive displacement pumps are typically used to achieve these elevated pressures. In the event of a process disturbance where the process line is dead headed – safety interlocks are required to ensure that excessive pressures do not exceed the system rating ensuring the overall safety of the system. Additionally, during CIP, some of these high pressure pumps require disassembly and removal of the pump internals to ensure adequate flow rates are achieved in the process line. This manual operation has many negative aspects which include:

- Safe “lock out tag out” procedures required
- Safe depressurization of process lines
- Frequent labor intensive disassembly of the pump, which can result in damage to the pump mechanism
- Increased effluent discharge from opening the line
- Operator dependent manual cleaning of internals in COP tanks
- Reassembly of pump internals into the pump can result in contamination of the clean line

Solution

The Norit Sudmo's Pressure Relief Valve guarantees personnel safety and full cleaning of the pump and process line. The adjustable spring tension allows the valve to be installed so that in the event of a process disturbance, the valve will relieve excess pressure allowing the pump to recirculate.

During CIP this valve can be opened to allow access flow around the pump – eliminating the need to disassemble the pump and COP. Norit Sudmo's Intellitop™ can be incorporated to give accurate position detection – confirming when an over pressure has occurred and also ensuring the bypass path is open during CIP. Significant cost savings are quickly realized as no manual input is required. CIP turn around times are reduced as zero time is required to switch from production to CIP and then back to production.

Pressure Relief Valve

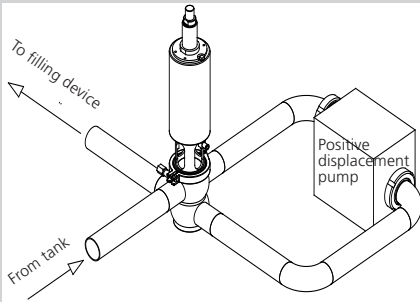

Benefits

- Pneumatic opening for CIP
- Hygienic and aseptic variants available
- Exchangeable with standard SVP and actuators of different relief ranges
- Easy adjustment and commissioning
- Easy maintenance — no special tools required
- Feedback available

Applications

Anywhere sanitary pressure relief protection is required. Norit Südmo also offers an alternative valve when ASME certification is required, such as on tanks.

Standard Specifications

Materials

- Product contact: 316L (1.4404)
- Non-product contact: 304 (1.4301)
- Optional: Hastelloy, AL6XN

Seals

- Standard: EPDM
- Optional: HNBR, FPM (Fluoro-Rubber), FFPM (Perfluorinated Fluoro-Rubber)

Operating Pressure

- Control air pressure: Standard 87-116 psi
- Product pressure: See spring ranges

Connections

- Standard: Sanitary O.D. tube butt weld
- Optional: Sanitary O.D. tube clamp
 - Welding ends for metric tubes
 - Welding ends for ISO tubes
 - DIN nut

Finish

- <= 32 Ra product contact
- <= 63 Ra non-product contact

Inches	Pressure Ranges
1/2 - 3/4	29 – 87 psi
1	7 – 29 psi
	7 – 58 psi
	36 – 116 psi
1 1/2	7 – 50 psi
	21 – 50 psi
	29 – 87 psi
	58 – 108 psi
2	7 – 36 psi
	36 – 65 psi
	50 – 108 psi
	87 – 174 psi
2 1/2	7 – 29 psi
	21 – 50 psi
	43 – 72 psi
	58 – 87 psi
	72 – 116 psi
3	123 – 195 psi
	50 – 65 psi
	58 – 87 psi
	79 – 130 psi
4	116 – 174 psi
	Upon Request

Contact us if required range is not shown.

Options

- Control Top
- Improved mechanical polish/electropolish
- 3.1B material certified



Südmo North America, Inc.

1330 Anvil Drive, Rockford, IL 61115 USA

T 815.639.0322 • F 815.639.1135

E info@sudmona.com • I www.sudmona.com

Südmo North America Inc. reserves the right to make changes in the technical specifications at any time.