

Model 801 $\frac{1}{8}$ DIN Controller

User Guide



ANDERSON INSTRUMENT COMPANY, INC.
156 Auriesville Road Fultonville, NY 12072
Ph: 800-833-0081, Fx: 800-922-7666

This manual supplements the Concise Product manual supplied with each instrument at the time of shipment. Information in this installation, wiring and operation manual is subject to change without notice.

Copyright © June 2004, Danaher Corporation, all rights reserved. No part of this publication may be reproduced, transmitted, transcribed or stored in a retrieval system, or translated into any language in any form by any means without the written permission of Anderson Instrument Co., Inc.

Copies of this manual are available in electronic format by contacting Anderson Instrument Co., Inc.

Note:

It is strongly recommended that applications incorporate a high or low limit protective device, which will shut down the equipment at a preset process condition in order to prevent possible damage to property or products.

**WARNING:**

THE INTERNATIONAL HAZARD SYMBOL IS INSCRIBED ADJACENT TO THE REAR CONNECTION TERMINALS. IT IS IMPORTANT TO READ THIS MANUAL BEFORE INSTALLING OR COMMISSIONING THE UNIT.

Products covered by this manual are suitable for Indoor use, Installation Category II, Pollution category 2 environments.

Warranty and Returns Statement

These products are sold by Anderson Instrument Co., Inc. under the warranties set forth in the following paragraphs. Such warranties are extended only with respect to a purchase of these products, as new merchandise, directly from Anderson Instrument Co., Inc. or from Anderson Instrument Co., Inc. distributor, representative or reseller and are extended only to the first buyer thereof who purchases them other than for the purpose of resale.

Warranty

These products are warranted to be free from functional defects in material and workmanship at the time the products leave Anderson Instrument Co., Inc. factory and to conform at that time to the specifications set forth in the relevant Anderson instruction manuals sheet or sheets, for such products for a period of three years.

THERE ARE NO EXPRESSED OR IMPLIED WARRANTIES, WHICH EXTEND BEYOND THE WARRANTIES HEREIN AND ABOVE SET FORTH. ANDERSON MAKES NO WARRANTY OF MERCHANTABILITY OR FITNESS FOR A PARTICULAR PURPOSE WITH RESPECT TO THE PRODUCTS.

Limitations

Anderson shall not be liable for any incidental damages, consequential damages, special damages, or any other damages, costs or expenses excepting only the cost or expense of repair or replacement as described above. Products must be installed and maintained in accordance with Anderson Instrument Co., Inc. instructions. There is no warranty against damage to the product resulting from corrosion. Users are responsible for the suitability of the products to their application.

For a valid warranty claim, the product must be returned carriage paid to the supplier within the warranty period. The product must be properly packaged to avoid damage from Electrostatic Discharge or other forms of harm during transit.

Contents

Warranty and Returns Statement	iv
Contents	v
How to use this manual	13
1 Introduction.....	14
2 Installation	15
2.1 Unpacking.....	15
2.2 Installation	15
2.3 Panel Cut-outs.....	16
2.4 Panel-Mounting	16
3 Plug-in Options.....	18
3.1 Options Modules and Functions	18
3.2 Auto Detection of Option Modules	18
3.3 Preparing to Install or Remove Options Modules	20
3.4 Removing/Replacing Option Modules.....	20
3.5 Replacing the Instrument in its Housing	23
4 Wiring Instructions.....	24
4.1 Installation Considerations.....	24
4.2 AC Power Wiring - Neutral (for 100 to 240V AC versions).....	24
4.3 Wire Isolation.....	24
4.4 Use of Shielded Cable	25
4.5 Noise Suppression at Source	25
4.6 Sensor Placement (Thermocouple or RTD).....	26
4.7 Connections and Wiring.....	27
4.7.1 Power Connections - Mains Powered Instruments	29
4.7.2 Power Connections - 24/48V AC/DC Powered Instruments	29
4.7.3 Universal Input Connections - Thermocouple (T/C).....	30
4.7.4 Universal Input Connections - RTD input.....	30
4.7.5 Universal Input Connections - Linear Volt, mV or mA input	31
4.7.6 Option Slot 1 - Relay Module.....	32
4.7.7 Option Slot 1 - SSR Driver Module	32
4.7.8 Option Slot 1 - Triac Module	32
4.7.9 Option Slot 1 - Linear Voltage or mADC module	33
4.7.10 Option Slot 2 - Relay Module	34

4.7.11	Option Slot 2 - SSR Driver Module	34
4.7.12	Option Slot 2 - Triac Module	34
4.7.13	Option Slot 2 - Dual Relay Module.....	35
4.7.14	Option Slot 2 - Linear Voltage or mADC module	35
4.7.15	Option Slot 3 - Relay Module.....	36
4.7.16	Option Slot 3 - SSR Driver Module	36
4.7.17	Option Slot 3 - Linear Voltage or mADC module	36
4.7.18	Option Slot 3 - Transmitter Power Supply Module	37
4.7.19	Option Slot A Connections - RS485 Serial Communications Module	38
4.7.20	Option Slot A Connections - Digital Input Module	38
4.7.21	Option Slot A Connections – Basic RSP.....	38
4.7.22	Option Slot B Connections – Heater Current Input.....	39
4.7.23	Option Slot B Connections – Digital Input 2.....	39
4.7.24	Option Slot B Connections – $\frac{1}{4}$ DIN & $\frac{1}{8}$ DIN Full RSP.....	39
5	Powering Up.....	40
5.1	Powering Up Procedure.....	40
5.2	Overview Of Front Panel	40
5.3	Displays	41
5.4	LED Functions	41
5.5	Keypad	41
6	Error/Faults Conditions.....	42
7	Instrument Operation Modes	43
7.1	Select Mode.....	43
7.1.1	Entry into the Select Mode.....	43
7.1.2	Navigating in Select Mode	43
7.2	Unlock Codes	44
7.3	Automatic Tune Mode.....	44
7.3.1	Navigating in Automatic Tune Mode.....	44
7.4	Product Information Mode	45
7.4.1	Navigating in the Product Information Mode.....	45
7.5	Lock Code View.....	47
7.5.1	Entry and Navigating in Lock Code View Mode.....	47
8	P8100 (AIC 801), P6100 , & P4100 Controller – Model Group.....	48
8.1	P8100 (AIC 801), P6100, & P4100 Controllers - Configuration Mode	48

8.1.1	Entry into the Configuration Mode	48
8.1.2	Scrolling Through Parameters and Values	48
8.1.3	Changing the Parameter Value	49
8.2	P8100 (AIC 801), P6100, & P4100 – Setup Mode.....	56
8.2.1	Entry into the Setup Mode	56
8.2.2	Scrolling Through Parameters & Values.....	56
8.2.3	Changing the Parameter.....	56
8.3	P8100 (AIC 801), P6100, & P4100 Controllers - Operator Mode	60
8.3.1	6100, 8100 & 4100 Controllers – Extended Operator Mode	60
8.3.2	Navigating in Operator Mode.....	60
8.4	Adjusting the Local Setpoint(s)	62
8.5	Adjusting the Setpoint Ramp Rate.....	62
8.6	Manual Control Mode	62
8.6.1	Selecting/deselecting Manual Control Mode.....	62
9	Manual Tuning Controllers.....	63
9.1	Controllers Fitted With Primary Output Only.....	63
9.2	Controllers Fitted With Primary and Secondary Outputs	64
9.3	Manual Fine Tuning.....	64
10	Modbus Serial Communications	66
10.1	Physical Layer	66
10.2	Link Layer	67
10.3	Device Addressing.....	68
10.4	Supported Modbus Functions.....	68
10.5	Function Descriptions	68
10.5.1	Read Coil/Input Status (Function 01 / 02).....	69
10.5.2	Read Holding/Input Registers (Function 03 / 04).....	69
10.5.3	Force Single Coil (Function 05)	70
10.5.4	Pre-Set Single Register (Function 06)	70
10.5.5	Loopback Diagnostic Test (Function 08)	70
10.5.6	Pre-Set Multiple Registers (Function 10 Hex).....	71
10.5.7	Exception Responses	71
11	ASCII Communications.....	72
11.1	Physical Layer	72
11.2	Device Addressing.....	72

11.3	Session Layer	72
11.3.1	Type 1 Message	74
11.3.2	Type 2 Message	74
11.3.3	Scan Tables.....	75
11.3.4	Type 3 Message	75
11.3.5	Type 4 Message	76
11.4	Error Response	76
12	Application Layer	77
12.1	Parameters.....	77
12.1.1	Bit Parameters.....	77
12.1.2	Word Parameters.....	78
12.2	Additional Parameter Details	83
12.2.1	Communications Write Enable.....	83
12.2.2	Equipment ID.....	83
12.2.3	Date of Manufacture	83
12.2.4	Product Revision Level	83
12.2.5	Firmware Version.....	83
13	Calibration Mode	84
13.1	Equipment Required For Checking or Calibrating the Universal Input.....	84
13.2	Calibration Check	84
13.3	Recalibration Procedure	85
14	Appendix 1 - Glossary	86
15	Appendix 2 - Specification	102
15.1	Universal Input.....	102
15.1.1	General Input Specifications	102
15.1.2	Thermocouple.....	102
	Thermocouple Ranges Available.....	102
	Thermocouple Performance	103
15.1.3	Resistance Temperature Detector (RTD)	103
	RTD Ranges Available	103
	RTD Performance.....	104
15.1.4	DC Linear	104
	DC Linear Ranges Available.....	104
	DC Linear Performance.....	104

15.2 Remote Setpoint Input.....	105
15.3 Digital Inputs.....	105
15.4 Output Specifications.....	106
15.4.1 Output Module Types	106
15.4.2 Generic Output Specifications	106
15.5 Control.....	107
15.6 Alarms	108
15.7 Digital Communications	108
15.8 Reference Conditions	108
15.9 Operating Conditions	108
15.10 Standards	109
15.11 Physical Specifications	109

List of Figures

Figure 1.	Main dimensions.....	15
Figure 2.	Panel cut-outs.....	16
Figure 3.	Panel-Mounting the instrument.....	16
Figure 4.	Typical rear view (uncased) showing main board positions.....	18
Figure 5.	Location of Option Modules - $\frac{1}{16}$ DIN Instruments	20
Figure 6.	Location of Option Modules - $\frac{1}{8}$ & $\frac{1}{4}$ DIN Instruments	21
Figure 7.	Option Module Connectors - $\frac{1}{16}$ DIN Instruments	21
Figure 8.	Option Module Connectors - $\frac{1}{8}$ & $\frac{1}{4}$ DIN Instruments	22
Figure 9.	Transient suppression with inductive coils.....	25
Figure 10.	Contact noise suppression	25
Figure 11.	Rear terminals ($\frac{1}{16}$ -DIN Instruments)	27
Figure 12.	Rear terminals ($\frac{1}{4}$ -DIN & $\frac{1}{8}$ -DIN Instruments).....	28
Figure 13.	Mains Power Connections.....	29
Figure 14.	24/48V AC/DC Power Connections.....	29
Figure 15.	Thermocouple Input Connections.....	30
Figure 16.	RTD Input Connections	30
Figure 17.	DC Volt, mV & mA Input Connections	31
Figure 18.	Option Slot 1 – Relay Module	32
Figure 19.	Option Slot 1 - SSR Driver Module	32
Figure 20.	Option Slot 1 - Triac Module	33
Figure 21.	Option Slot 1 - Linear Voltage & mADC Module	33
Figure 22.	Option Slot 2 - Relay Module.....	34
Figure 23.	Option Slot 2 - SSR Driver Module	34
Figure 24.	Option Slot 2 - Triac Module	34
Figure 25.	Option Slot 2 - Dual Relay Module.....	35
Figure 26.	Option Slot 2 - Linear Voltage & mADC module	35
Figure 27.	Option Slot 3 - Relay Module.....	36
Figure 28.	Option Slot 3 - SSR Driver Module	36
Figure 29.	Option Slot 3 - Linear Voltage & mADC module	37
Figure 30.	Option Slot 3 - Transmitter Power Supply Module.....	37
Figure 31.	Option Slot A – RS485 Serial Communications Module	38
Figure 32.	Option Slot A – Digital Input Module	38
Figure 33.	Option Slot A – Basic RSP Input Module.....	38

Figure 34.	Option Slot B – Heater Current Input Connections	39
Figure 35.	Option Slot B – Digital Input 2 Connections.....	39
Figure 36.	Option Slot B – Full Remote Setpoint Input Connections	39
Figure 37.	Typical front panels.....	40
Figure 38.	Manual Tuning.....	64
Figure 39.	Link Layer	67
Figure 40.	Alarm Hysteresis Operation.....	86
Figure 41.	Alarm Operation.....	87
Figure 42.	Overlap and Deadband.....	93
Figure 43.	Pre-Tune Operation	95
Figure 44.	Self-Tune Operation	99

List of Tables

Table 1.	Option Module vs. Model Matrix	19
Table 2.	LED functions	41
Table 3.	Error/Faults conditions.....	42
Table 4.	Model Groups	43
Table 5.	Select Mode.....	43
Table 6.	Lock code values.....	44
Table 7.	Automatic Tune Mode Parameters	45
Table 8.	Product Information Mode Parameters	46
Table 9.	Lock Codes.....	47
Table 10.	6100, 8100 & 4100 Configuration Mode Parameters.....	49
Table 11.	6100, 8100 & 4100 Set Up Mode Parameters	57
Table 12.	6100, 8100 & 4100 Operator Mode Displays.....	60
Table 13.	Supported Modbus Functions	68
Table 14.	Read Coil/Input Status (Function 01/02).....	69
Table 15.	Read Holding/Input Registers (Function 03/04)	69
Table 16.	Force Single Coil (Function 05)	70
Table 17.	Pre-Set Single Register (Function 06)	70
Table 18.	Loopback Diagnostic Test (Function 08)	70
Table 19.	Pre-Set Multiple Registers (Function 10 Hex).....	71
Table 20.	Exception Responses	71
Table 21.	Parameter Key.....	73
Table 22.	Data Element – Sign/Decimal Point Position	73
Table 23.	Standard scan table.....	75
Table 24.	VMD control mode scan table.....	75
Table 25.	Bit Parameters	77
Table 26.	Word Parameters.....	78
Table 27.	Firmware Version.....	83
Table 28.	Calibration phases	85
Table 29.	Logical Alarm Outputs	91

How to use this manual

Each section of this manual is structured to give information required for all aspects of the installation and use and of the product:

Section 1: **Introduction** - gives a brief description of the product range.

Section 2: **Installation** - contains step-by-step instructions for unpacking, installing and panel mounting the instrument.

Section 3: **Plug-in Options** – explains installation of the plug-in option modules.

Section 4: **Wiring Guidelines** - gives guidance on good wiring practice, noise avoidance, wiring diagrams and input/output connections.

Section 5: **Powering Up** - explains the powering up procedure and gives a brief description of the displays and switches.

Section 6: **Error Messages** – explains the various error or fault indication displays.

Section 7: **Operation Modes** - contains a description of all the operation modes common across the range. These include Select Mode for gaining access to the Setup and Configuration menus, Automatic tuning on controllers and the Product information menu.

Section 8: **P8100 (AIC 801), P6100, & P4100 Model Group** - contains a description of all menus unique to the three controllers in this model group. These include Configuration Mode, Setup Mode and the normal Operator Mode menus. It also details adjustment of the controller setpoint and the use of manual control mode.

Section 9: **Manually Tuning Controllers** – gives advice on manually adjusting the PID controller tuning parameters.

Section 10: **Modbus Serial Communications** – contains details of the physical layer and message formats used in the Modbus serial communications protocol common to all products in the range.

Section 12: **ASCII Serial Communications** – contains details of the physical layer and message formats used in ASCII serial communications protocol available (in addition to Modbus) in some products in the range.

Section 12: **Serial Communications Application Layer** – contains details of the parameter addressing for both Modbus and ASCII serial communications protocols.

Section 13: **Calibration Mode**- contains step-by-step instructions to calibrate the instrument. This section is intended for use by an engineer.

Appendix 1: **Glossary** – explains the terms used in this manual and the features of the products.

Appendix 2: **Specification** - contains the technical specifications for all instruments in the range.

1 Introduction

These instruments are microprocessor based indicators, single loop controllers, and profilers capable of measuring, displaying or controlling process variables such as temperature, pressure, flow and level from a variety of inputs. Models are available in three DIN case sizes. $\frac{1}{16}$ DIN Instruments have 48 x 48mm front panels. $\frac{1}{8}$ DIN front panels are 48 x 96mm and $\frac{1}{4}$ - DIN front panels are 96 x 96mm.

Control functions, alarm settings and other parameters are easily entered through the front keypad or by using the PC based configuration software. Controller models are easily tuned using the instruments automatic tuning features. EEPROM technology protects against data or configuration loss during AC power outages.

Inputs are user configurable for direct connection to thermocouple and RTD probes. Most models will also accept linear process signal types such as mVDC, VDC or mADC.

If the instrument is configured with a linear output option module, this output can be scaled to re-transmit the process variable or setpoint to external devices such as data recorders or PLC's.

The operating voltage is either 100-240 VAC, 50/60 Hz power supply or 24V-48V AC/DC power supply depending on the model purchased.

Alarm indication is standard on all instruments; up to three alarms are possible on some models. The alarm types may be set as process high or low, deviation (active above or below controller setpoint), band (active both above and below setpoint), or control loop type. Models with a heater current input also have high, low or short circuit heater break alarms based on control load current. These alarms can be linked to any suitable output.

Alarm status is indicated by an LED and the alarm status screen.

If the instrument is configured with the transmitter power supply option module, an unregulated 24V DC (22mA) auxiliary output voltage is provided to power external signal transmitters.

Controllers can be programmed for on-off, time proportioning, or current proportioning control implementations, depending on the output modules fitted. A secondary control output is available when the appropriate extra output module is fitted. Valve Motor Drive (VMD) is also possible on some models. All proportional control implementations are provided with fully programmable PID parameters. Controllers with analogue Remote Setpoint inputs and Profile Controllers are included in the range.

2 Installation

2.1 Unpacking

1. Remove the product from its packing. Retain the packing for future use, in case it is necessary to transport the instrument to a different site or to return it to the supplier for repair/testing.
2. The instrument is supplied with a panel gasket and push fit fixing strap. A single sheet concise manual is also supplied in one or more languages. Examine the delivered items for damage or defects. If any are found, contact your supplier immediately.

2.2 Installation

CAUTION:

Installation and configuration should be performed only by personnel who are technically competent and authorised to do so. Local regulations regarding electrical installation and safety must be observed.

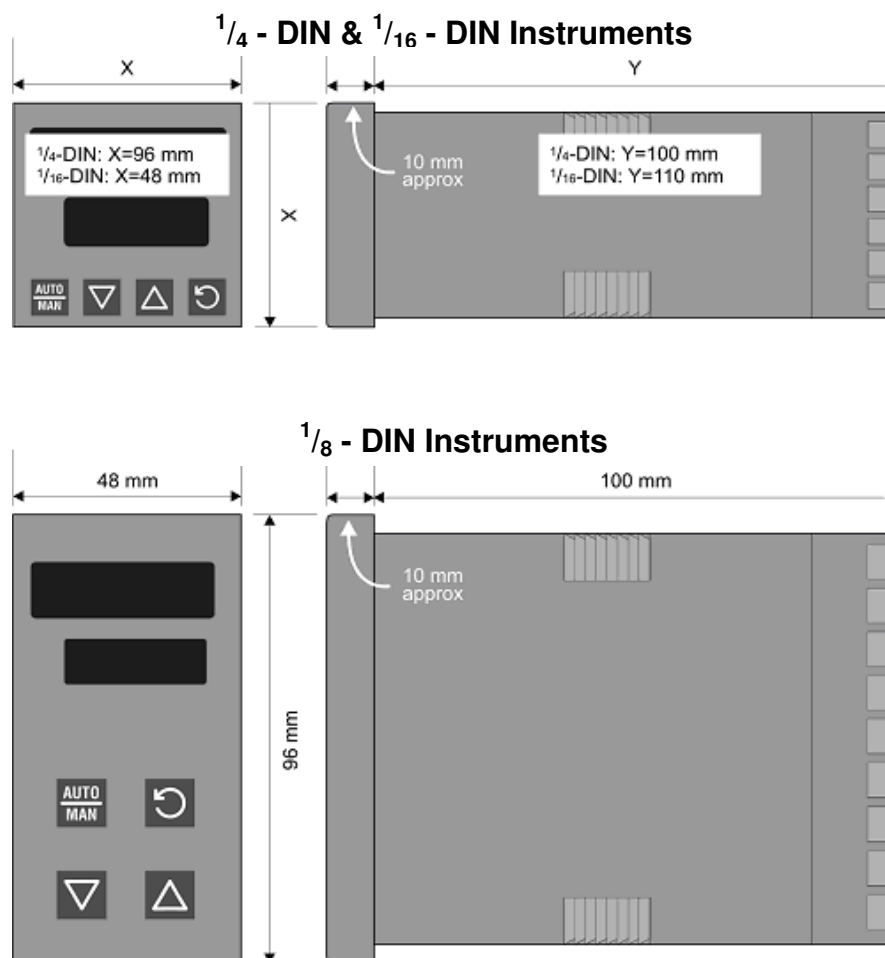

Figure 1. Main dimensions

2.3 Panel Cut-outs

The mounting panel must be rigid and may be up to 6.0mm (0.25 inches) thick. The cut-outs required for the instruments are shown below.

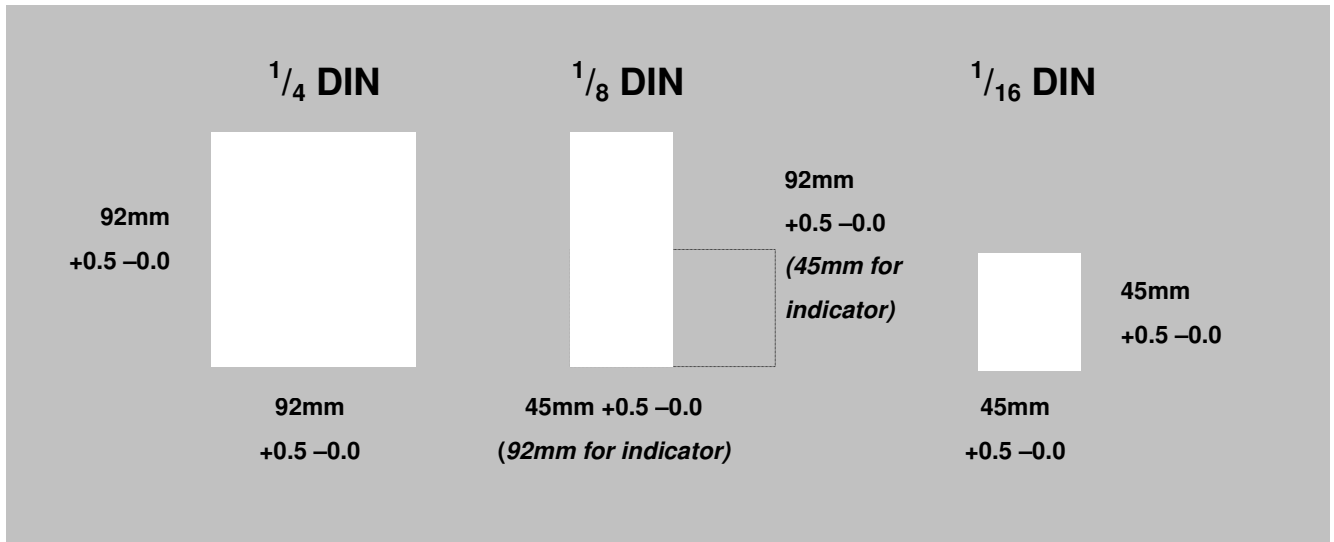

Figure 2. Panel cut-outs

2.4 Panel-Mounting

CAUTION:

Ensure the inside of the panel is with the instruments operating temperature and that there is adequate air flow to prevent overheating.

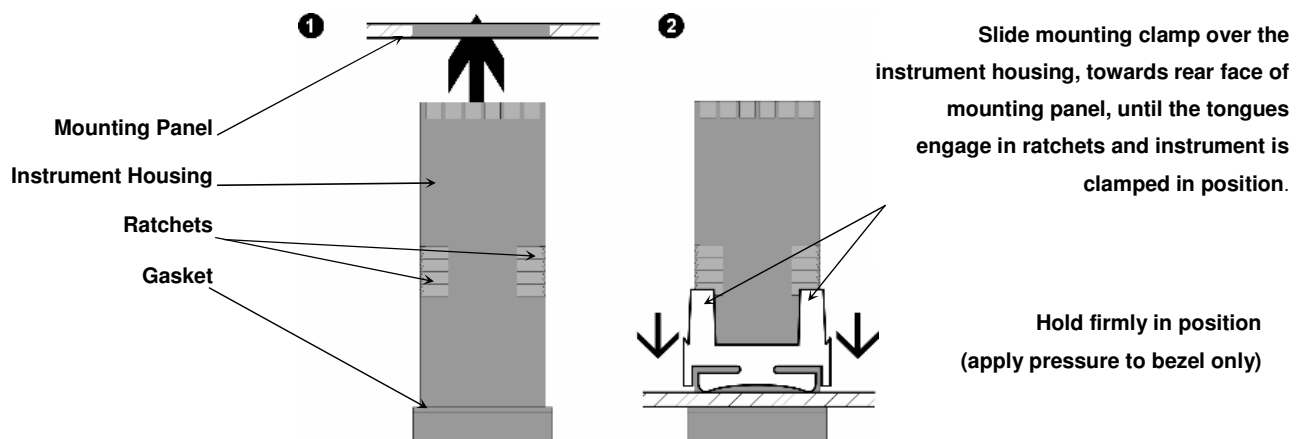

Figure 3. Panel-Mounting the instrument

CAUTION:

Do not remove the panel gasket, as this may result in inadequate clamping and sealing of the instrument to the panel.

Once the instrument is installed in its mounting panel, it may be subsequently removed from its housing, if necessary, as described in the Fitting and Removing Option Modules section.

Instruments may be mounted side-by-side in a multiple installation, but instrument to panel moisture and dust sealing will be compromised. Cut-out width (for n instruments) is:

$\frac{1}{8}$ - & $\frac{1}{16}$ - **DIN Instruments:** $(48n - 4)$ mm or $(1.89n - 0.16)$ inches

$\frac{1}{4}$ - **DIN Instruments:** $(96n - 4)$ mm or $(3.78n - 0.16)$ inches

If panel sealing must be maintained, mount each instrument into an individual cut-out with 6mm or more clearance between the edges of the holes.

Note:

The mounting clamp tongues may engage the ratchets either on the sides or the top/bottom faces of the Instrument housing. When installing several Instruments side-by-side in one cut-out, use the ratchets on the top/bottom faces.

3 Plug-in Options

3.1 Options Modules and Functions

A range of plug-in option modules are available to add additional input, output and communication functions to the instruments in the range. These modules can be either pre-installed at the time of manufacture, or retrofitted in the field.

The modules are installed between the instruments main circuit boards into the four option slots. These are designated as Slots 1, 2, 3, A & B. Installation is detailed below.

Note:

Slot 1 modules cannot be fitted into Slot 2 or 3. Slot 2 & 3 modules cannot be fitted into Slot 1. Some Slot 2 & 3 modules should only be fitted into one of the two slots. This is detailed in the - Option Module vs. Model Matrix below.

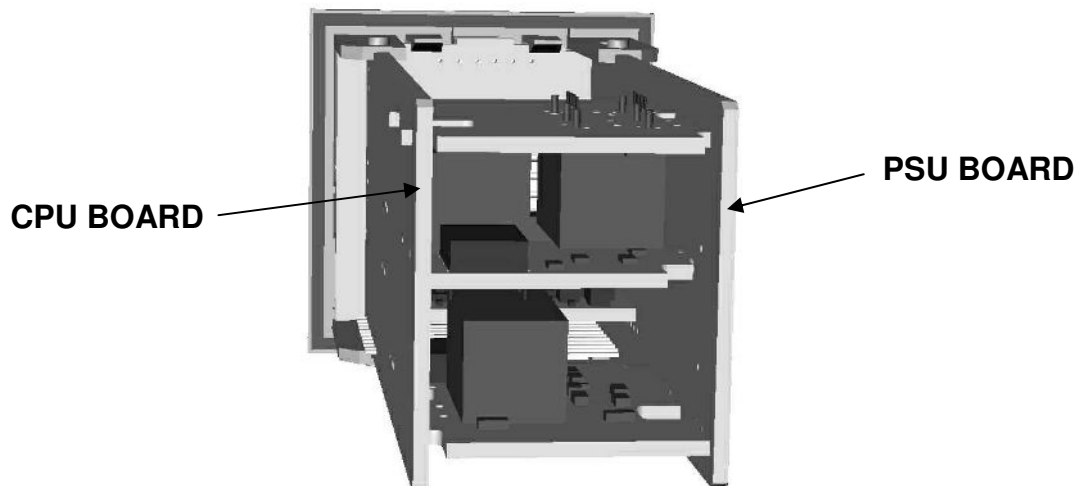

Figure 4. Typical rear view (uncased) showing main board positions

3.2 Auto Detection of Option Modules

The instrument automatically detects which option modules have been fitted into each slot. In Configuration Mode, the menus will change to reflect the options compatible with the hardware fitted. The modules fitted can be viewed in the Product Information Mode.

Table 1. Option Module vs. Model Matrix

MODULE PART NUMBER & Function	MODEL NUMBER											
	P6100	P6120	P6600	P8100 (801)	P8600	P4100	P6700	P8700	P4700	P6400	P6010	P8010
OPTION SLOT 1												
PO1-C10 Relay												
PO1-C50 SSR Driver												
PO1-C80 Triac												
PO1-C21 Linear mA/V DC												
OPTION SLOT 2												
PO2-C10 Relay												
PO2-C50 SSR Driver												
PO2-C80 Triac												
PO2-C21 Linear mA/V DC												
PO2-W09 Dual Relay												
OPTION SLOT 3												
PO2-C10 Relay												
PO2-C50 SSR Driver												
PO2-C21 Linear mA/V DC												
PO2-W08 TransmitterPSU												
OPTION SLOT A												
PA1-W06 RS485 Comms												
PA1-W03 Digital Input												
PA1-W04 Basic RSP Input												
OPTION SLOT B												
PB1-W0R Full RSP Input												
SOFTWARE & ACCESSORIES												
PS1-CON Config Software												
KEY	Option Possible						Option Not Possible					

3.3 Preparing to Install or Remove Options Modules

CAUTION:

Before removing the instrument from its housing, ensure that all power has been removed from the rear terminals.

1. Remove the instrument from its housing by gripping the side edges of the front panel (there is a finger grip on each edge) and pull the instrument forwards. This will release the instrument from the rear connectors in the housing and will give access to the PCBs.
2. Take note of the orientation of the instrument for subsequent replacement into the housing. The positions of the main and option PCBs in the instrument are shown below.

3.4 Removing/Replacing Option Modules

With the instrument removed from its housing:

1. To remove or replace modules into Option Slots 1, A or B, it is necessary to gently separate the CPU and PSU PCBs. This is achieved by detaching the main boards (PSU and CPU) from the front moulding by lifting first the upper, and then lower mounting struts as shown. This frees the boards from the front. If only Option slots 2 or 3 are to be changed, this stage is not required as these slots are accessible without separating the main boards from the front.

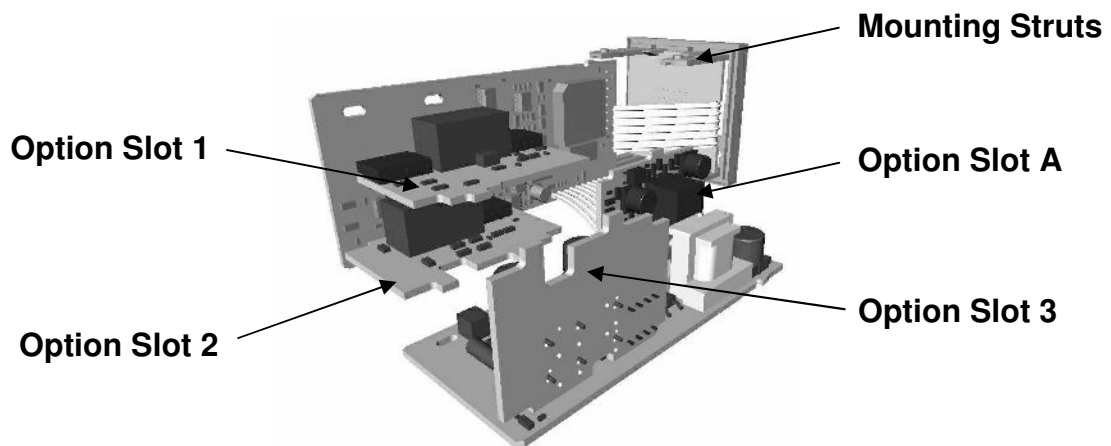

Figure 5. Location of Option Modules - ¹/₁₆ DIN Instruments

CAUTION:

Take care not to put undue stress on the ribbon cable attaching the display and CPU boards.

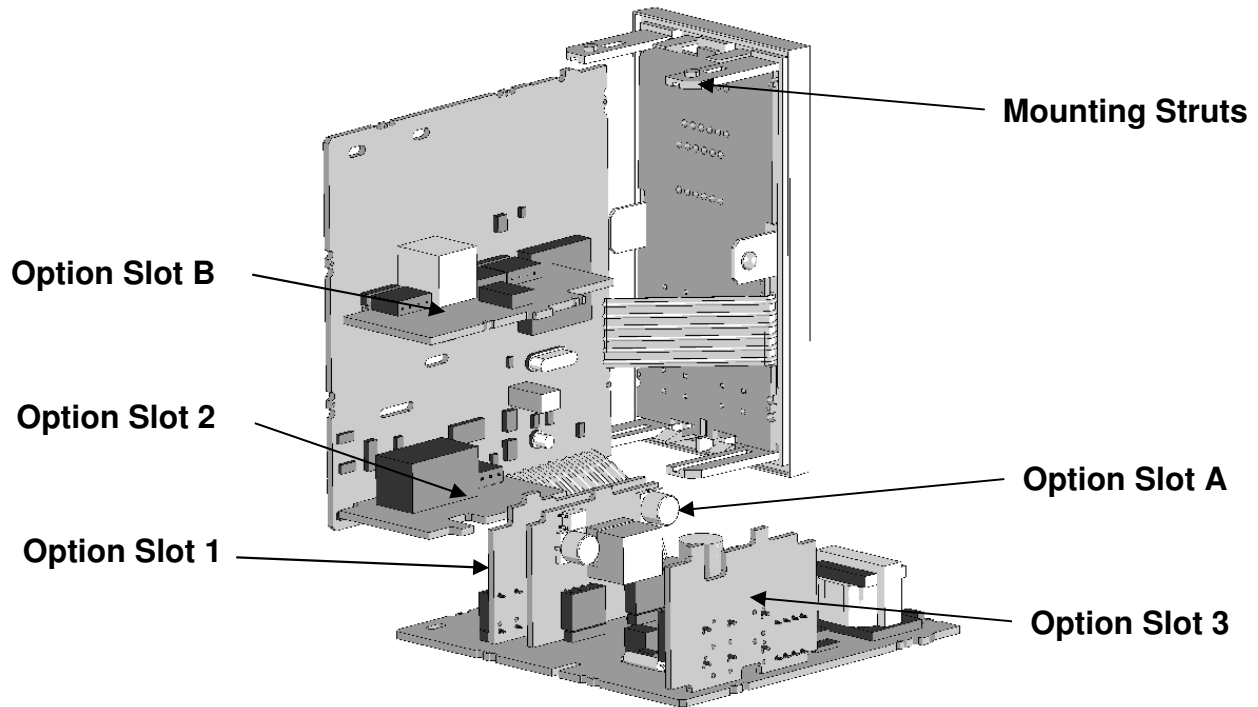

Figure 6. Location of Option Modules - ¹/₈ & ¹/₄ DIN Instruments

CAUTION:

Take care not to put undue stress on the ribbon cable attaching the display and CPU boards.

2. Remove or fit the modules into the Option slots as required. The location of the connectors is shown below. Tongues on each option module locate into a slots cut into the main boards, opposite each of the connectors.

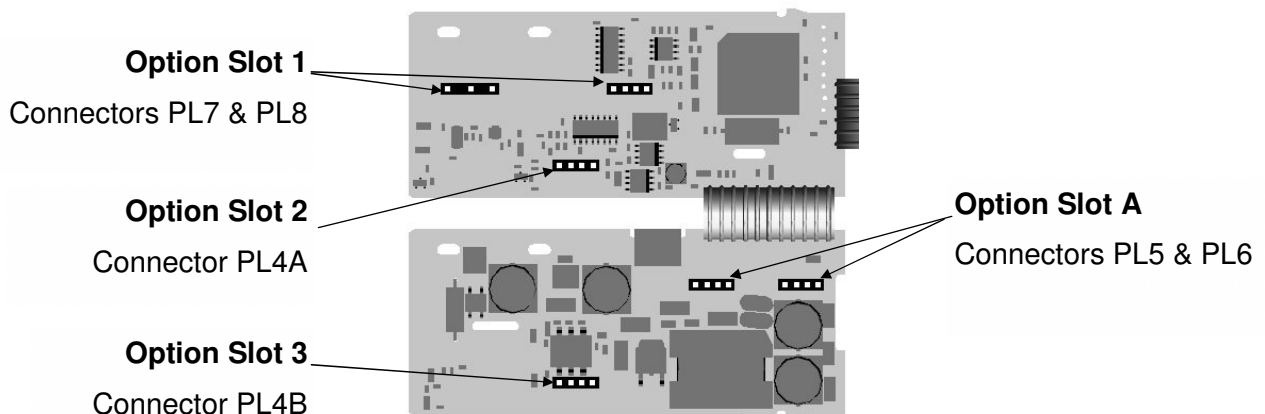

Figure 7. Option Module Connectors - ¹/₁₆ DIN Instruments

CAUTION:

Check for correct orientation of the modules and that all pins locate correctly into the socket

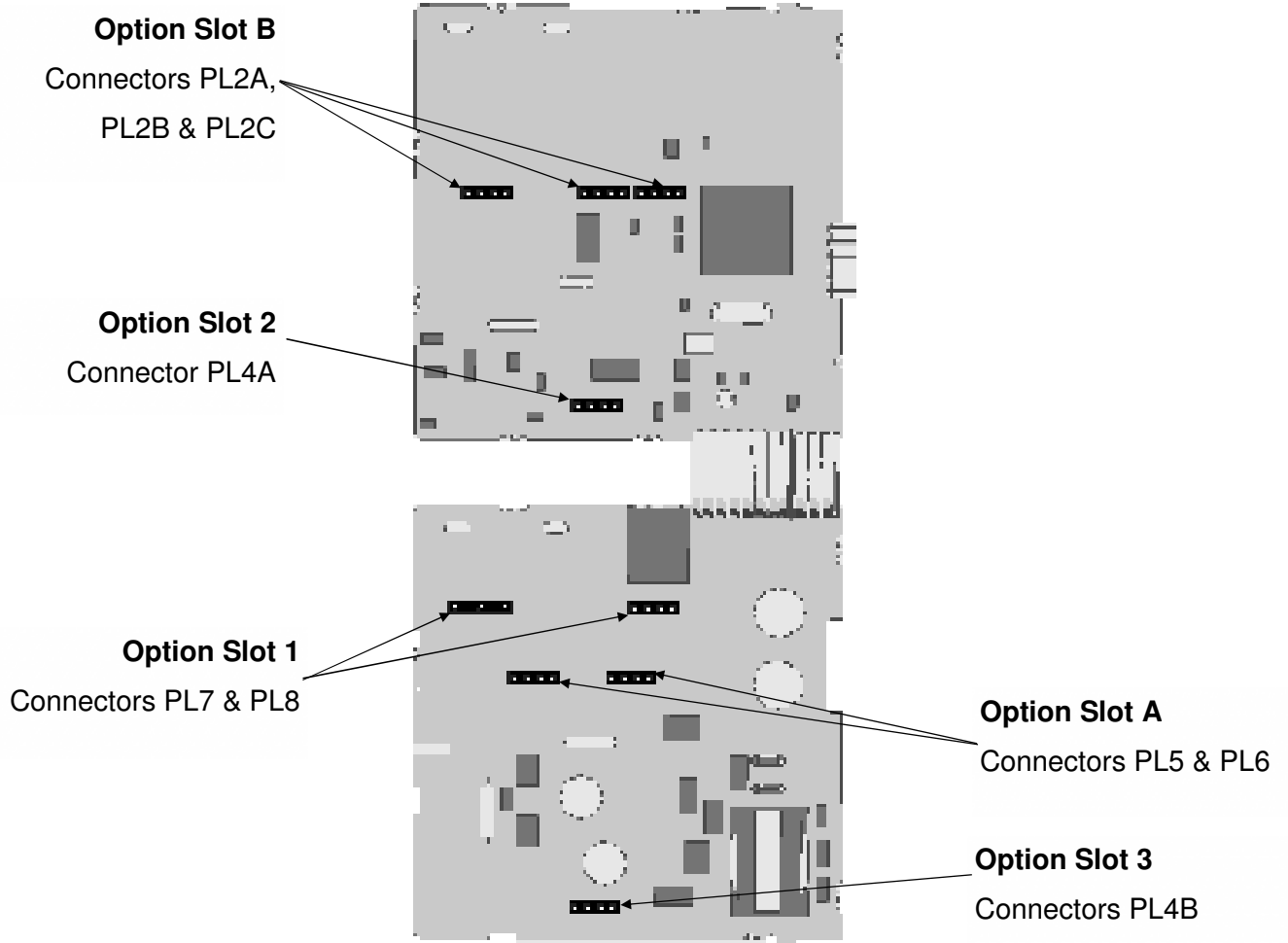

Figure 8. Option Module Connectors - $\frac{1}{8}$ & $\frac{1}{4}$ DIN Instruments

CAUTION:

Check for correct orientation of the modules and that all pins locate correctly into the socket

3.5 Replacing the Instrument in its Housing

With the required option modules correctly located into their respective positions the instrument can be replaced into its housing as follows:

1. If required, move the CPU and PSU boards back together, taking care to locate the option module tongues into the slots in the board opposite. Hold the main boards together whilst relocating them back into the mounting struts on the front panel.
2. Align the CPU and PSU PCBs with their guides and connectors in the housing.
3. Slowly and firmly, push the instrument in position.

CAUTION:

Ensure that the instrument is correctly orientated. A mechanical stop will operate if an attempt is made to insert the instrument in the wrong orientation, this stop MUST NOT be over-ridden.

4 Wiring Instructions

Electrical noise is a phenomenon typical of industrial environments. As with any instrumentation, these guidelines should be followed to minimize the effect of noise.

4.1 Installation Considerations

Ignition transformers, arc welders, mechanical contact relays and solenoids are all common sources of electrical noise in an industrial environment and therefore the following guidelines MUST be followed.

1. If the instrument is being installed in existing equipment, the wiring in the area should be checked to ensure that good wiring practices have been followed.
2. Noise-generating devices such as those listed should be mounted in a separate enclosure. If this is not possible, separate them from the instrument, by the largest distance possible.
3. If possible, eliminate mechanical contact relays and replace with solid-state relays. If a mechanical relay being powered by an output of this instrument cannot be replaced, a solid-state relay can be used to isolate the instrument.
4. A separate isolation transformer to feed only the instrumentation should be considered. The transformer can isolate the instrument from noise found on the AC power input.

4.2 AC Power Wiring - Neutral (for 100 to 240V AC versions)

It is good practice to ensure that the AC neutral is at or near ground (earth) potential. A proper neutral will help ensure maximum performance from the instrument.

4.3 Wire Isolation

Four voltage levels of input and output wiring may be used with the unit:

1. Analogue input or output (for example thermocouple, RTD, VDC, mVDC or mADC)
2. Relays & Triac outputs
3. SSR Driver outputs
4. AC power

CAUTION:

The only wires that should run together are those of the same category.

If any wires need to run parallel with any other lines, maintain a minimum space of 150mm between them.

If wires MUST cross each other, ensure they do so at 90 degrees to minimise interference.

4.4 Use of Shielded Cable

All analogue signals must use shielded cable. This will help eliminate electrical noise induction on the wires. Connection lead length must be kept as short as possible keeping the wires protected by the shielding. The shield should be grounded at one end only. The preferred grounding location is at the sensor, transmitter or transducer.

4.5 Noise Suppression at Source

Usually when good wiring practices are followed, no further noise protection is necessary. Sometimes in severe electrical environments, the amount of noise is so great that it has to be suppressed at source. Many manufacturers of relays, contactors etc supply 'surge suppressors' which mount on the noise source. For those devices that do not have surge suppressors supplied, Resistance-Capacitance (RC) networks and/or Metal Oxide Varistors (MOV) may be added.

Inductive coils:- MOVs are recommended for transient suppression in inductive coils, connected in parallel and as close as possible to the coil. Additional protection may be provided by adding an RC network across the MOV.

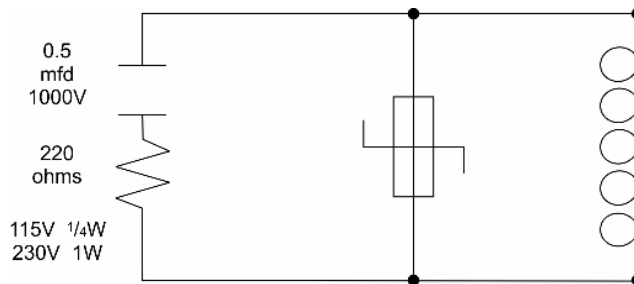
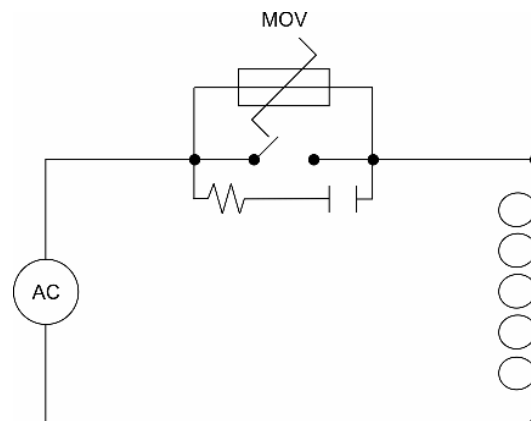

Figure 9. Transient suppression with inductive coils

Contacts:- Arcing may occur across contacts when they open and close. This results in electrical noise as well as damage to the contacts. Connecting a properly sized RC network can eliminate this arc.



For circuits up to 3 amps, a combination of a 47 ohm resistor and 0.1 microfarad capacitor (1000 volts) is recommended. For circuits from 3 to 5 amps, connect two of these in parallel.

Figure 10. Contact noise suppression

4.6 Sensor Placement (Thermocouple or RTD)

If the temperature probe is to be subjected to corrosive or abrasive conditions, it must be protected by an appropriate thermowell. The probe must be positioned to reflect true process temperature:

1. In a liquid media - the most agitated area
2. In air - the best circulated area

CAUTION:

The placement of probes into pipe work some distance from the heating vessel leads to transport delay, which results in poor control.

For a two wire RTD a wire link should be used in place of the third wire. Two wire RTDs must only be used with lead lengths less than 3 metres. Use of three wire RTDs is strongly recommended.

4.7 Connections and Wiring

The rear terminal connections for $\frac{1}{16}$ DIN and $\frac{1}{4}$ & $\frac{1}{8}$ DIN instruments are illustrated in the following diagrams.

In general, all wiring connections are made to the instrument after it is installed. Copper wires must be used for all connections (except thermocouple signal wires).

WARNING:

TO AVOID ELECTRICAL SHOCK, AC POWER WIRING MUST NOT BE CONNECTED TO THE SOURCE DISTRIBUTION PANEL UNTIL ALL WIRING PROCEDURES ARE COMPLETED.

WARNING:

CHECK THE INFORMATION LABEL ON THE CASE TO DETERMINE THE CORRECT VOLTAGE BEFORE CONNECTING TO A LIVE SUPPLY.

Note:

The wiring diagram below shows all possible combinations. The actual connections required depend upon the features available on the model and the modules and options fitted.

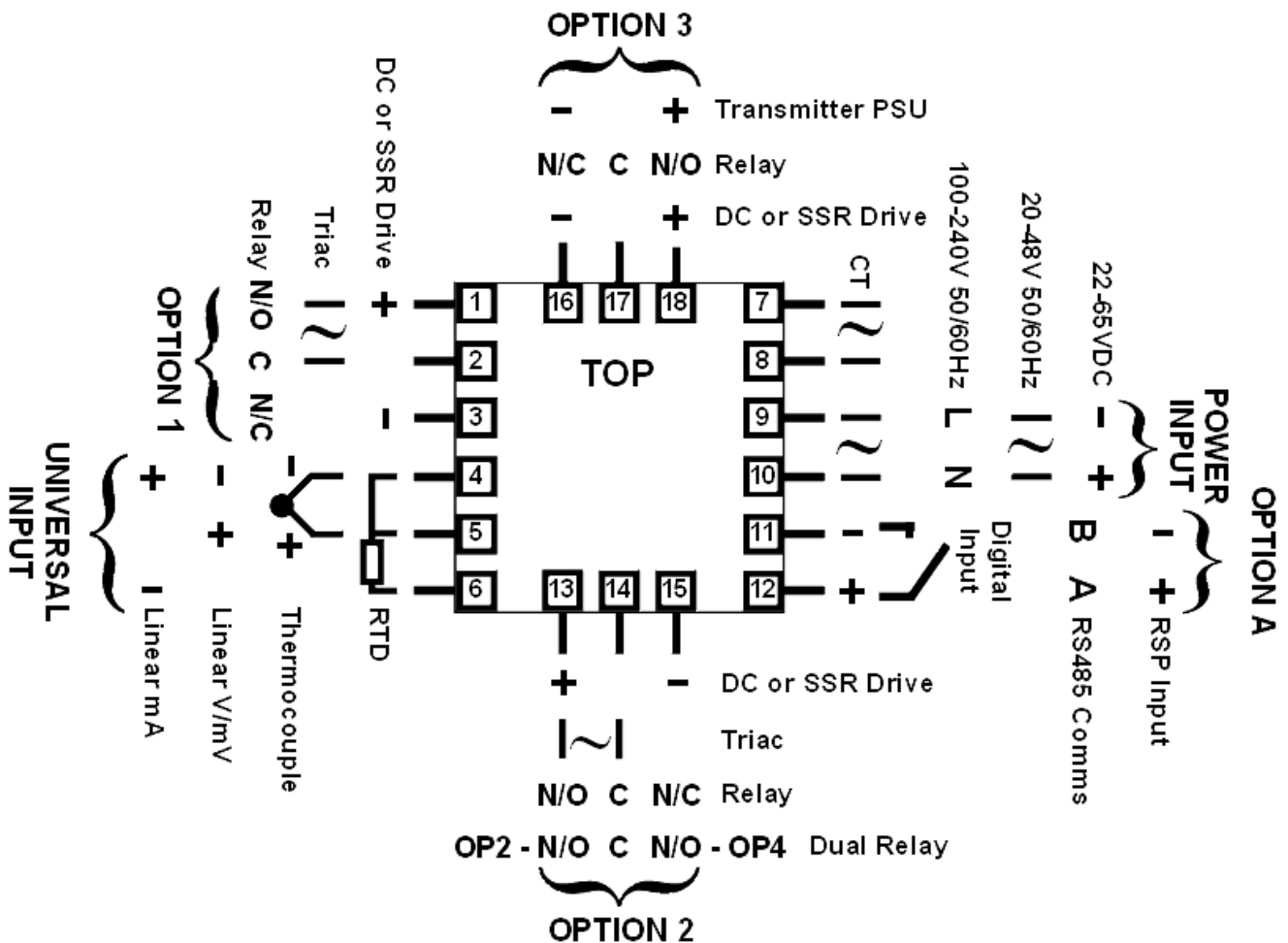

Figure 11. Rear terminals ($\frac{1}{16}$ -DIN Instruments)

WARNING:

TO AVOID ELECTRICAL SHOCK, AC POWER WIRING MUST NOT BE CONNECTED TO THE SOURCE DISTRIBUTION PANEL UNTIL ALL WIRING PROCEDURES ARE COMPLETED.

WARNING:

CHECK THE INFORMATION LABEL ON THE CASE TO DETERMINE THE CORRECT VOLTAGE BEFORE CONNECTING TO A LIVE SUPPLY.

Note:

The wiring diagram below shows all possible combinations. The actual connections required depend upon the features available on the model and the modules and options fitted.

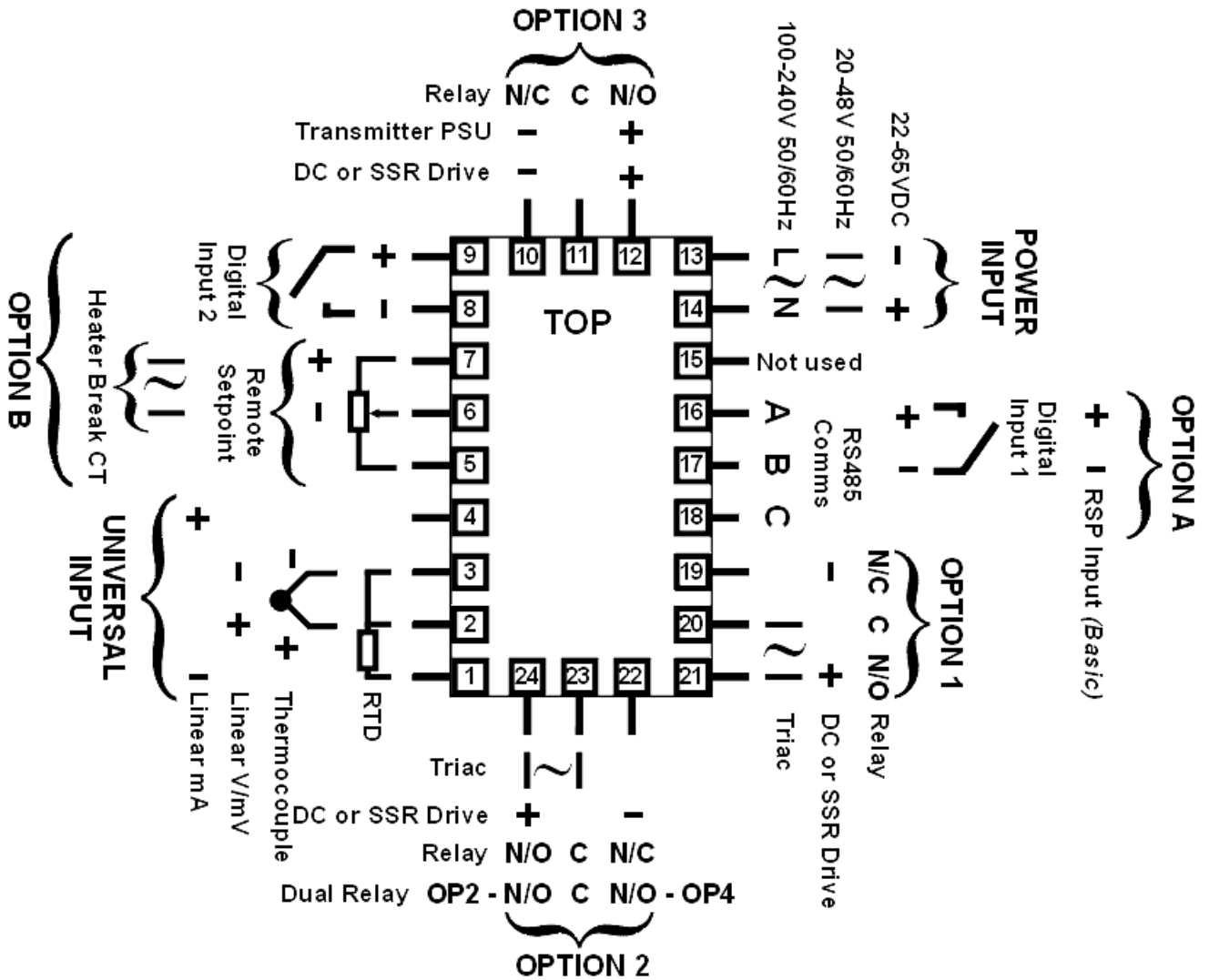

Figure 12. Rear terminals (1/4-DIN & 1/8-DIN Instruments)

Figure 13.

4.7.1 Power Connections - Mains Powered Instruments

Mains powered instruments operate from a 100 to 240V ($\pm 10\%$) 50/60Hz supply. Power consumption is 7.5VA. Connect the line voltage (live and neutral) as illustrated via a two-pole isolating switch (preferably located near the equipment) and a 1 amp anti-surge fuse. If the instrument has relay outputs with contacts carrying mains voltage, it is recommended that the relay contacts supply should be switched and fused in a similar manner, but should be separate from the instruments mains supply.

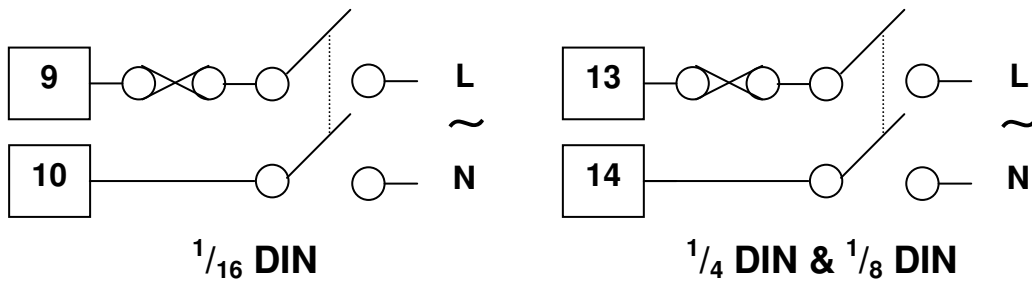

Figure 14. Mains Power Connections

WARNING:

CHECK THE INFORMATION LABEL ON THE CASE TO DETERMINE THE CORRECT VOLTAGE BEFORE CONNECTING TO A LIVE SUPPLY.

CAUTION:

This equipment is designed for installation in an enclosure that provides adequate protection against electric shock

4.7.2 Power Connections - 24/48V AC/DC Powered Instruments

24/48V AD/DC powered instruments will operate from a 20 to 48V AC or 22 to 55V DC supply. AC power consumption is 7.5VA max, DC power consumption is 5 watts max. Connection should be via a two-pole isolating switch (preferably located near the equipment) and a 315mA slow-blow (anti-surge type T) fuse.

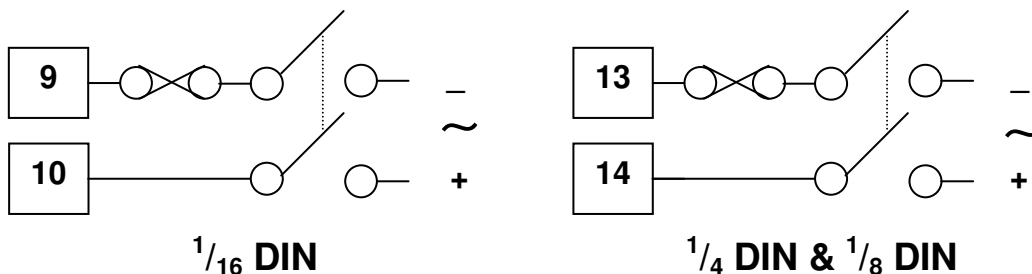

Figure 15. 24/48V AC/DC Power Connections

WARNING:

CHECK THE INFORMATION LABEL ON THE CASE TO DETERMINE THE CORRECT VOLTAGE BEFORE CONNECTING TO A LIVE SUPPLY.

4.7.3 Universal Input Connections - Thermocouple (T/C)

Use only the correct thermocouple wire or compensating cable from the probe to the instrument terminals avoiding joints in the cable if possible. Failure to use the correct wire type will lead to inaccurate readings. Ensure correct polarity of the wires by cross-referencing the colours with a thermocouple reference table.



Figure 16. Thermocouple Input Connections

4.7.4 Universal Input Connections - RTD input

For three wire RTDs, connect the resistive leg and the common legs of the RTD as illustrated. For a two wire RTD a wire link should be used in place of the third wire (shown by dotted line). Two wire RTDs should only be used when the leads are less than 3 metres long. Avoid cable joints.

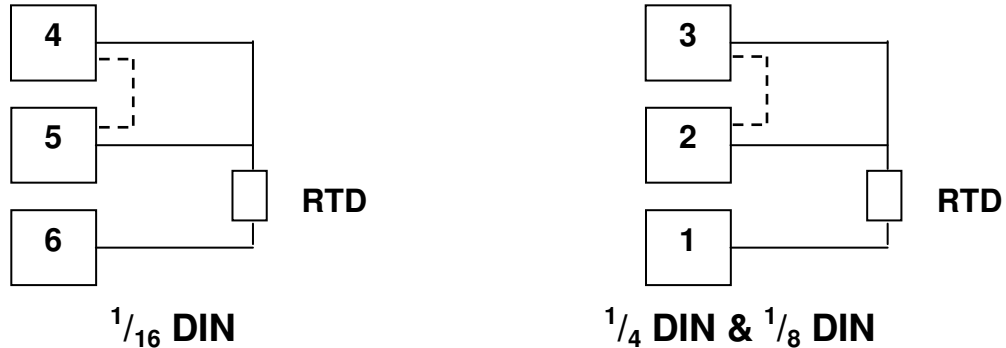

Figure 17. RTD Input Connections

Four wire RTD's can be used, provided that the fourth wire is left unconnected. This wire should be cut short or tied back so that it cannot contact any of the terminals on the rear of the instrument.

4.7.5 Universal Input Connections - Linear Volt, mV or mA input

Linear DC voltage, millivolt or milliamp input connections are made as illustrated. Carefully observe the polarity of the connections.

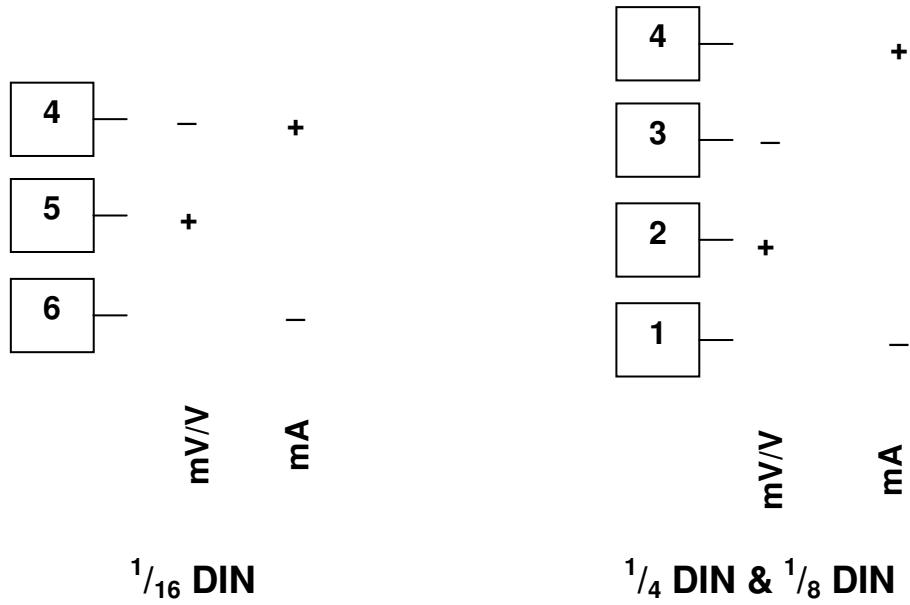

Figure 18. DC Volt, mV & mA Input Connections

4.7.6 Option Slot 1 - Relay Module

If option slot 1 is fitted with a relay output module, make connections as illustrated. The relay contacts are rated at 2 amps resistive, 120/240 VAC.

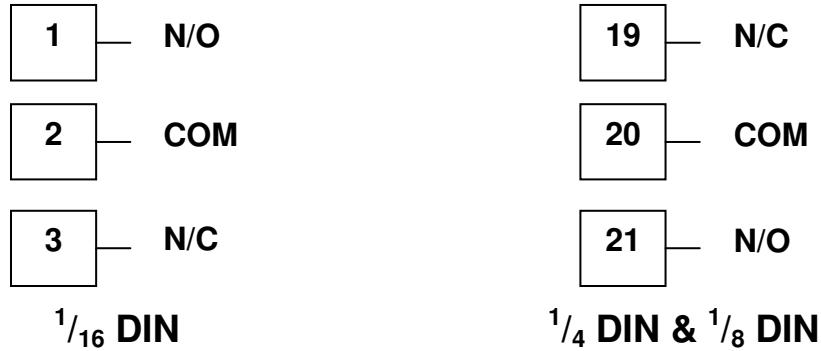
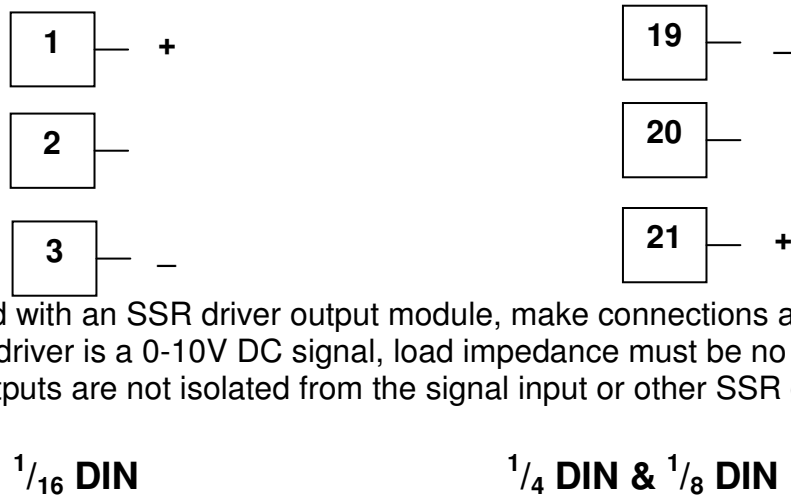

Figure 19. Option Slot 1 – Relay Module

4.7.7 Option Slot 1 - SSR Driver Module



If option slot 1 is fitted with an SSR driver output module, make connections as illustrated. The solid-state relay driver is a 0-10V DC signal, load impedance must be no less than 500 ohms. SSR driver outputs are not isolated from the signal input or other SSR driver outputs.

Figure 20. Option Slot 1 - SSR Driver Module

4.7.8 Option Slot 1 - Triac Module

If option slot 1 is fitted with a Triac output module, make connections as illustrated. The triac output is rated at 0.01 to 1 amp @ 240V AC 50/60Hz.



Figure 21. Option Slot 1 - Triac Module

4.7.9 Option Slot 1 - Linear Voltage or mADC module

If option slot 1 is fitted with a DC linear output module, make connections as illustrated.



Figure 22. Option Slot 1 - Linear Voltage & mADC Module

4.7.10 Option Slot 2 - Relay Module

If option slot 2 is fitted with a relay output module, make connections as illustrated. The contacts are rated at 2 amp resistive 120/240 VAC.



Figure 23. Option Slot 2 - Relay Module

4.7.11 Option Slot 2 - SSR Driver Module

If option slot 2 is fitted with an SSR driver output module, make connections as illustrated. The solid-state relay driver is a 0-10V DC signal, load impedance must be no less than 500 ohms. SSR driver outputs are not isolated from the signal input or other SSR driver outputs.

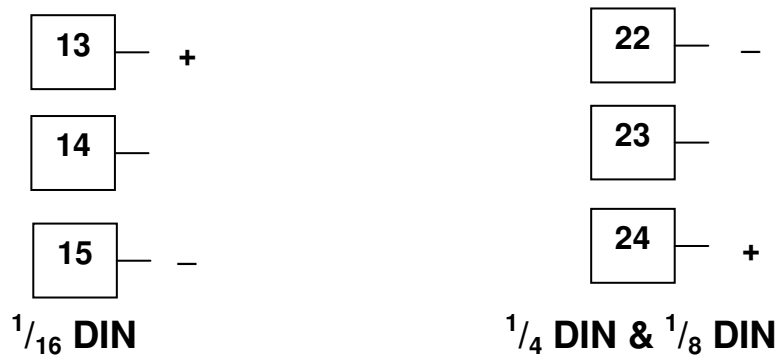

Figure 24. Option Slot 2 - SSR Driver Module

4.7.12 Option Slot 2 - Triac Module

If option slot 2 is fitted with a triac output module, make connections as illustrated. The triac is rated at 0.01 to 1 amp @ 240V AC 50/60Hz

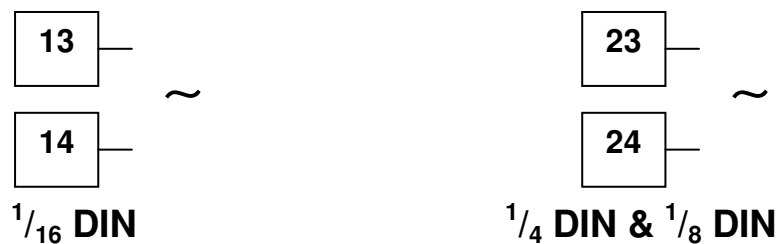

Figure 25. Option Slot 2 - Triac Module

WARNING:

THIS MODULE MUST NOT BE FITTED INTO OPTION SLOT 3.

4.7.13 Option Slot 2 - Dual Relay Module

If option slot 2 is fitted with a dual relay output module, make connections as illustrated. This module has two independent relays, which share a common connection terminal. The contacts are rated at 2 amp resistive 120/240 VAC.

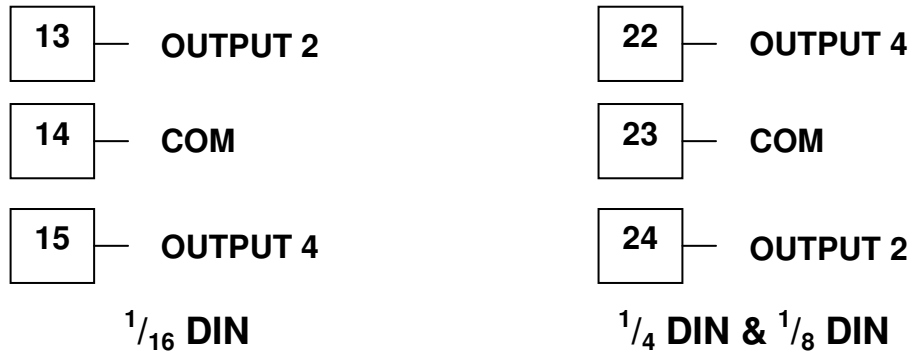

Figure 26. Option Slot 2 - Dual Relay Module

WARNING:

THIS MODULE MUST NOT BE FITTED INTO OPTION SLOT 3.

4.7.14 Option Slot 2 - Linear Voltage or mADC module

If option slot 2 is fitted with a DC linear output module, make connections as illustrated.



Figure 27. Option Slot 2 - Linear Voltage & mADC module

4.7.15 Option Slot 3 - Relay Module

If option slot 3 is fitted with a relay output module, make connections as illustrated. The contacts are rated at 2 amp resistive 120/240 VAC.

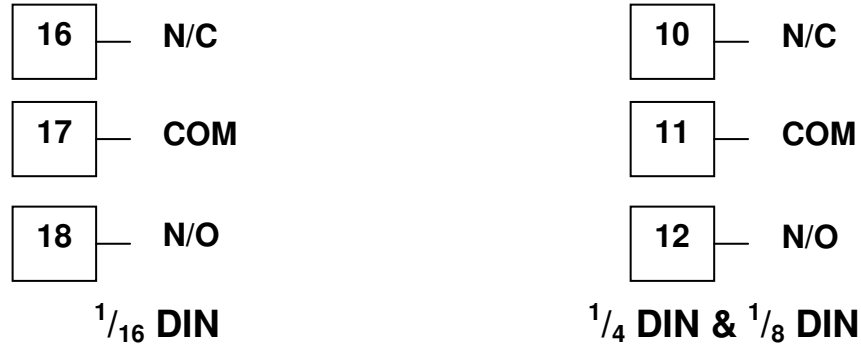

Figure 28. Option Slot 3 - Relay Module

4.7.16 Option Slot 3 - SSR Driver Module

If option slot 3 is fitted with an SSR driver output module, make connections as illustrated. The solid-state relay driver is a 0-10V DC signal; load impedance must be no less than 500 ohms. SSR driver outputs are not isolated from the signal input or other SSR driver outputs.



Figure 29. Option Slot 3 - SSR Driver Module

4.7.17 Option Slot 3 - Linear Voltage or mADC module

If option slot 3 is fitted with a DC linear output module, make connections as illustrated.

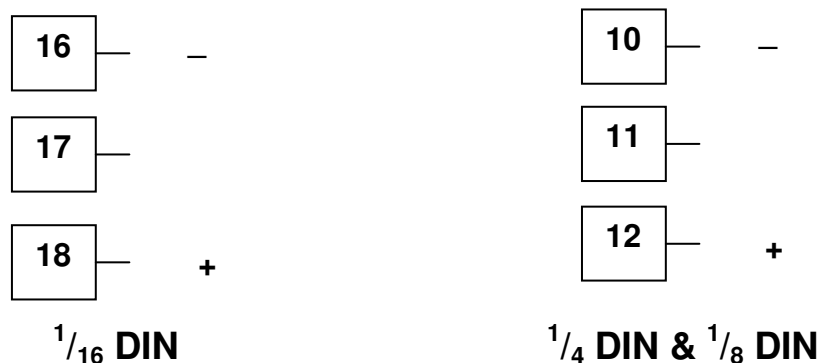

Figure 30. Option Slot 3 - Linear Voltage & mADC module

4.7.18 Option Slot 3 - Transmitter Power Supply Module

If option slot 3 is fitted with a transmitter power supply module, make connections as illustrated. The output is an unregulated 24V DC, 22mA supply.

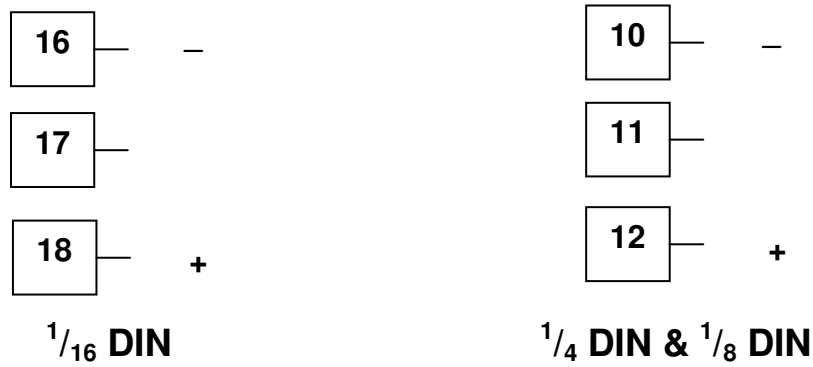

Figure 31. Option Slot 3 - Transmitter Power Supply Module

WARNING:

THIS MODULE MUST NOT BE FITTED INTO OPTION SLOT 2.

4.7.19 Option Slot A Connections - RS485 Serial Communications Module

If option slot A is fitted with the RS485 serial communication module, connections are as illustrated. Carefully observe the polarity of the A (Rx/Tx +ve) and B (Rx/Tx -ve) connections.

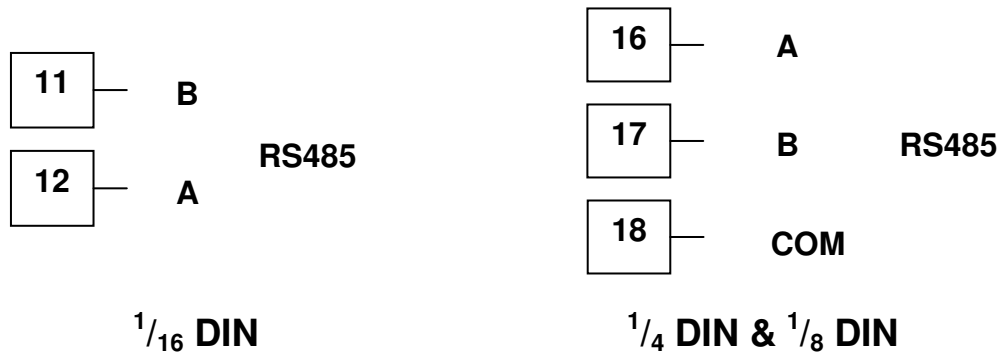

Figure 32. Option Slot A – RS485 Serial Communications Module

4.7.20 Option Slot A Connections - Digital Input Module

If a digital input module is fitted in option slot A, this may be connected to either voltage free contacts (e.g. switch or relay), or a TTL compatible voltage. Connections are shown below.



Figure 33. Option Slot A – Digital Input Module

4.7.21 Option Slot A Connections – Basic RSP

If option slot A is fitted with a basic remote setpoint module, input connections are as shown. For ¹/₄-DIN & ¹/₈-DIN models it is recommended that the full RSP (Option Slot B) is used instead, as this has additional features and keeps option slot A free for other modules.



Figure 34. Option Slot A – Basic RSP Input Module

WARNING:

THIS MODULE MUST NOT BE FITTED IF FULL RSP HAS BEEN FITTED IN OPTION SLOT B.

4.7.22 Option Slot B Connections – Heater Current Input

If the heater current measurement feature is available, connections from the secondary winding of the current transformer are as illustrated below.

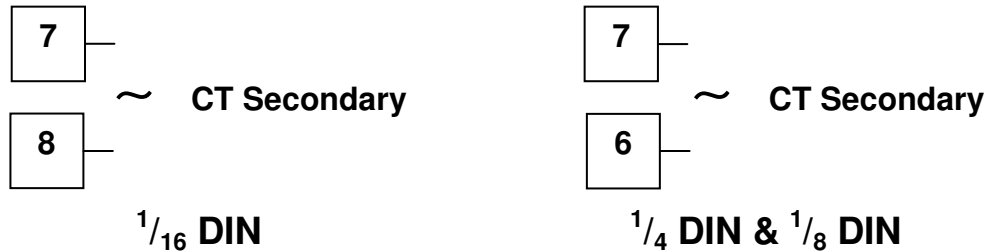

Figure 35. Option Slot B – Heater Current Input Connections

4.7.23 Option Slot B Connections – Digital Input 2

If option slot B is fitted with the Full RSP input module (see below), a secondary digital input is also provided. This may be connected to either the voltage free contacts of a switch or relay, or a TTL compatible voltage.

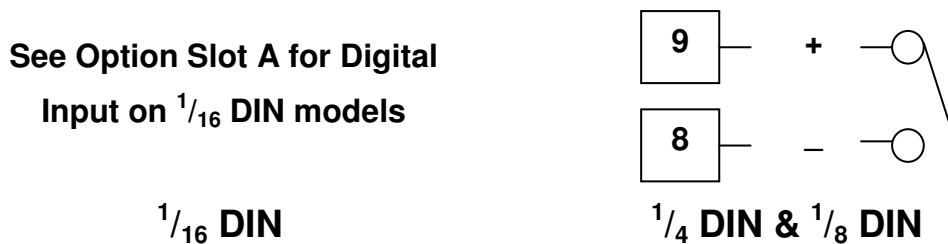

Figure 36. Option Slot B – Digital Input 2 Connections

4.7.24 Option Slot B Connections – ¹/₄ DIN & ¹/₈ DIN Full RSP

If option slot B is fitted with full remote setpoint feature, input connections are as shown.

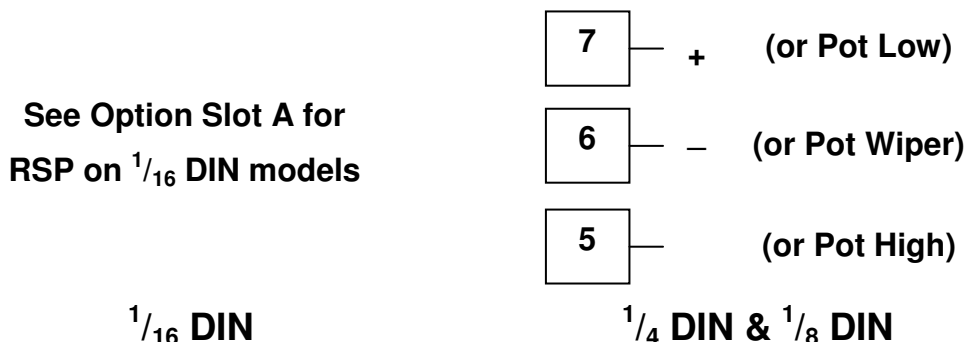

Figure 37. Option Slot B – Full Remote Setpoint Input Connections

WARNING:

IF THE FULL RSP MODULE HAS BEEN FITTED, THE BASIC RSP MUST NOT BE FITTED INTO OPTION SLOT A.

5 Powering Up

WARNING:

ENSURE SAFE WIRING PRACTICES ARE FOLLOWED

The instrument must be powered from a supply according to the wiring label on the side of the unit. The supply will be either 100 to 240V AC, or 24/48V AC/DC powered. Check carefully the supply voltage and connections before applying power.

CAUTION:

When powering up for the first time, disconnect the output connections.

5.1 Powering Up Procedure

When the instrument is powered up, a self-test procedure is automatically started, during which all LED segments and indicators are lit. At the first ever power up, or if option modules are changed *Go to Conf* will then be displayed, indicating the configuration is required. Otherwise the instrument returns to operator mode once the self-test procedure is complete.

5.2 Overview Of Front Panel

The illustration below shows a typical instrument front panel. Each model in the range will vary slightly from the example shown. Refer to the following table - LED functions for a description of the front panel indicators.

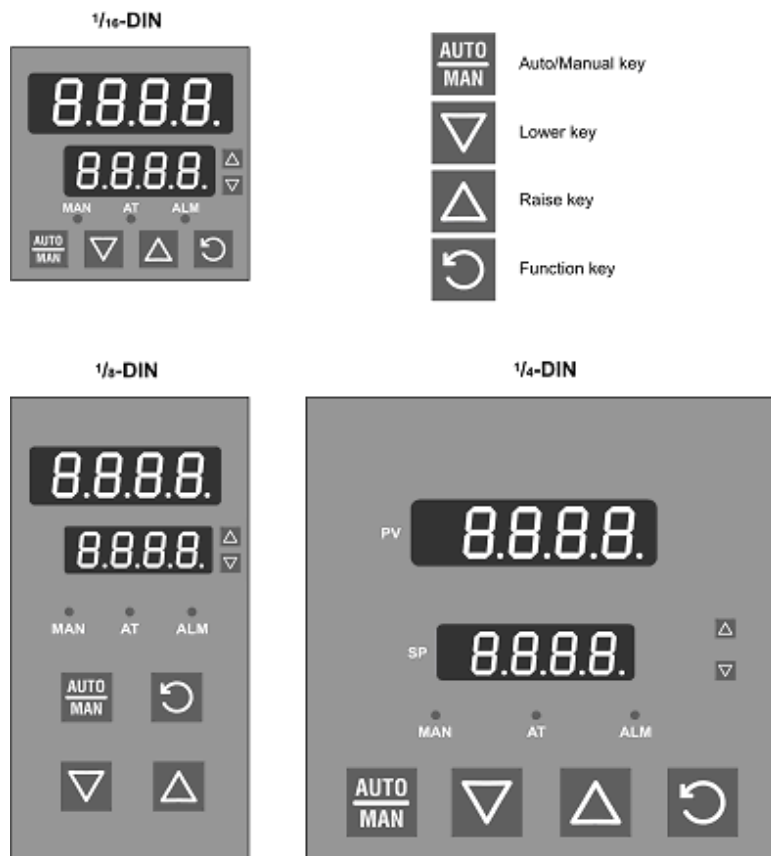









Figure 38. Typical front panels

5.3 Displays

Indicator models have a single line display, which normally shows the process variable value, and status indicators LED's for mode and alarm indication. Controllers are provided with a dual line display and LED indicators for mode, automatic tune, alarm and output status. The upper display shows the process variable value during normal operation, whilst the lower display shows the setpoint value. See the preceding diagram - Typical front panels.

5.4 LED Functions

Table 2. LED functions

LED	Function
	ON indicates the Setup Mode has been entered
	FLASHING indicates the manual mode has been entered
	ON indicates the Self Tune mode has been engaged
	FLASHING indicates the Pre-Tune mode has been engaged
	FLASHING indicates that an alarm condition is present
	FLASHES in unison with Time Proportioning Primary outputs (for Current Proportioned linear outputs, ON indicates power is >0%)
	FLASHES in unison with Time Proportioning Secondary outputs (for Current Proportioned linear outputs, ON indicates power is >0%)





5.5 Keypad

Each instrument in the range has either three of four switches, which are used to navigate through the user menus and make adjustment to the parameter values. See the preceding diagram - Typical front panels

6 Error/Faults Conditions

The following displays are shown when an error has occurs or a hardware change has been detected.

Table 3. Error/Faults conditions

Upper display	Lower Display	Error/Faults Conditions
GoTo	ConF	Configuration & Setup required. Seen at first turn on or if hardware configuration changed. Press  to enter the Configuration Mode, then press  or  to enter the unlock code number, then press  to proceed. Configuration must be completed before return to operator mode is allowed ¹
[HH]	Normal Display	Input more than 5% over-range ²
[LL]	Normal Display	Input more than 5% under-range ³
OPEN	Normal Display	Sensor Break. Break detected in the input sensor or wiring
Normal Display	[HH]**	RSP input over-range
Normal Display	[LL]**	RSP input under-range
Normal Display	OPEN**	RSP Break. Break detected in the remote setpoint input
Err	OPn1	Option 1 - module faulty.
	OPn2	Option 2 - module faulty.
	OPn3	Option 3 - module faulty.
	OPnA	Option A – module faulty.
	OPnb	Option B – module faulty.

**** Note**

RSP break and over/under-range indication will be seen wherever the RSP value would be displayed.

¹ This feature does not guarantee correct configuration but only helps to ensure that the unit will be configured by the user before use. Use of set-up mode is not enforced but may be essential to set the controller up for the users process.

² If the PV display exceeds 9999 before 5% over-range is reached then the over-range indication is given.

³ If the PV display is less than -1999 before 5% under-range is reached then the under-range indication is given.

7 Instrument Operation Modes

All instruments in the range share a similar user interface. Similar modes are shared by all models within a group of instruments. For more details refer to the table below.



Table 4. Model Groups

Model Group	Description	Model Group	Description
P6100, P8100 (AIC 801) & P4100	Controllers	P4700, P6700 & P8700	Limit Controllers
P6120	Controller	P6400	Profile Controller
P6600, P8600	Controllers	P6010	Indicator
		P8010	Indicator



7.1 Select Mode

This mode is used to gain entry to each of the modes available in the instrument. For more details refer to the Select Mode table below.

7.1.1 Entry into the Select Mode











Hold down  and press  in any mode to force the unit to enter Select Mode.

7.1.2 Navigating in Select Mode

Once in Select Mode, press  or  to select the required mode, then press  to enter the chosen mode.

To prevent unauthorised entry to Configuration, Setup and Automatic Tuning modes, an unlock code is required. These are shown in the - Lock code values table.

Table 5. Select Mode

Mode	Upper Display	Lower Display	Description
Operator Mode			The Default Mode on power up used for normal operation of the instrument.
Set Up Mode			Used to tailor the instrument settings to the application, adjustment of tuning terms etc.
Configuration Mode			Used to configure the instrument for first time use or on re-installation.
Product Information Mode			Used to check the hardware, firmware and manufacturing information of the instrument.
Automatic Tune Mode			Used to invoke the pre-tune and/or self-tune on PID controllers.

Note:

The details of these modes vary depending on the Model Group in question.

7.2 Unlock Codes



The **ULoc** screen is seen before entry is allowed to Configuration, Setup and Automatic Tuning modes. An unlock code must be correctly selected using the  or  keys. An incorrect entry results in a return to Select Mode.

Table 6. Lock code values

Lower Display	Upper Display	Description
ULoc	0	Default values are: Automatic Tune Mode = 0 Set-up mode = 10 Configuration Mode = 20 .



Note:

The unlock codes can be changed from within the modes that they apply to.



7.3 Automatic Tune Mode

Automatic Tune Mode is selected when it is desired to use the Pre-tune and Self-tune facilities of the controller to assist the user in setting up Proportional band, Integral and Derivative parameter values. Refer to the following Automatic Tune Mode table.

Pre-tune can be used to set the Controllers PID parameters approximately. Self-tune may then be used to optimise the tuning. Pre-tune can be set to run automatically after every power-up using the Auto Pre-Tune **APT** parameter in Setup Mode.

The **AT** indicator will flash  while pre-tune is operating, and is continuously on  whilst Self-tune is operating. If both Pre-tune and Self-tune are engaged the **AT** indicator will flash until Pre-tune is finished, then turn fully on.

7.3.1 Navigating in Automatic Tune Mode

Press  to select the next parameter in the table and  or  to set the value required.

Hold down  and press  to return to Select Mode.

Note:

If there is no key activity for 2 minutes the controller automatically returns to operator mode

Table 7. Automatic Tune Mode Parameters

Parameter	Lower Display	Upper Display Adjustment Range	Default Value	When Visible
Pre-tune	<i>Ptun</i>	<i>On</i> or <i>OFF</i> . Indication remains <i>OFF</i> if Pre-Tune cannot be used at this time. This applies if: a). The setpoint is ramping b). The process variable is less than 5% of span from the setpoint c). The primary or secondary output proportional bands = 0	<i>OFF</i>	Always
Self-tune	<i>Stun</i>	<i>On</i> or <i>OFF</i> . Indication remains <i>OFF</i> if Self-Tune cannot be used at this time. This applies if either proportional band = 0.	<i>OFF</i>	Always
Automatic tune mode lock code	<i>tLoc</i>	0 to 9999	<i>0</i>	Always

7.4 Product Information Mode

This is a read only mode describing the instrument and the options fitted to it.

7.4.1 Navigating in the Product Information Mode

Press  to view each parameter in turn.

Hold Down  and press  to return to Select Mode.

Note:

If there is no key activity for 2 minutes the controller automatically returns to operator mode



Table 8. Product Information Mode Parameters

Parameter	Lower Display	Upper Display	Possible Values	When Visible
Input type	<i>In_1</i>	<i>Un_1</i>	Universal input	Always
Option 1 module type	<i>OPn1</i>	<i>nonE</i>	No option fitted	Always
		<i>rLY</i>	Relay	
		<i>SSr</i>	SSR drive	
		<i>tr_1</i>	Triac	
		<i>L in</i>	Linear voltage / current output	
Option 2 module type	<i>OPn2</i>	<i>nonE</i>	No option fitted.	Always
		<i>rLY</i>	Relay	
		<i>SSr</i>	SSR drive	
		<i>tr_1</i>	Triac	
		<i>L in</i>	Linear voltage / current output	
Option 3 module type	<i>OPn3</i>	<i>nonE</i>	No option fitted.	Always
		<i>rLY</i>	Relay	
		<i>SSr</i>	SSR drive	
		<i>L in</i>	Linear voltage / current output	
		<i>dc24</i>	Transmitter power supply	
Auxiliary option A module type	<i>OPnA</i>	<i>nonE</i>	No option fitted	Always
		<i>r485</i>	RS485 comms	
		<i>dIG_1</i>	Digital Input	
		<i>rSP_1</i>	Basic remote setpoint input	
Auxiliary option B module type	<i>OPnb</i>	<i>nonE</i>	No option fitted	Always
		<i>rSP_1</i>	Full RSP input and digital input 2	
Firmware	<i>FLW</i>	Value displayed is firmware type number		Always
Issue No.	<i>ISS</i>	Value displayed is firmware issue number		
Product Rev Level	<i>PrL</i>	Value displayed is Product Revision Level.		
Date of manufacture	<i>dOrr7</i>	Manufacturing date code (mmyy)		
Serial number 1	<i>Sn1</i>	First four digits of serial number		
Serial number 2	<i>Sn2</i>	Second four digits of serial number		
Serial number 3	<i>Sn3</i>	Last four digits of serial number		

7.5 Lock Code View

In the event that a lock code is forgotten, the instrument lock code values can be seen in the lock code view (read only).

7.5.1 Entry and Navigating in Lock Code View Mode

Press  and  together whilst the instrument is powering up until the **CLoc** display is shown.

Once in this mode

Press  to step between lock codes.

Note:

If there is no key activity for 2 minutes the instrument returns to the operator mode. To forcefully exit this view, switch off the instrument.

Table 9. Lock Codes

Lock Code Name	Upper Display	Lower Display	Description
Configuration Lock Code	CLoc	Current value	Read only view of Configuration Lock Code.
Setup Lock Code	SLoc	Current value	Read only view of Setup Mode Lock Code.
Automatic Tune Lock-code	tLoc	Current value	Read only view of Automatic Tune Lock Code.

8 P6100, P8100 (AIC 801) & P4100 Controller – Model Group

These controllers combine technical functionality, field flexibility and ease of use to give you the best in comprehensive process control. The P6100 $\frac{1}{16}$ –DIN Controller (48 x 48mm), P8100 (AIC 801) $\frac{1}{8}$ –DIN Controller (96 x 48mm) and P4100 $\frac{1}{4}$ –DIN Controller (96 x 96mm) offer similar functionality in three DIN sizes.

- Heat/Cool operation
- Auto/Manual Tuning
- Two process alarms
- Ramping setpoint
- Loop alarm
- Remote or Dual setpoint selection
- RS485 Modbus and ASCII comms
- Configuration via PC

8.1 P6100, P8100 (AIC 801) & P4100 Controllers - Configuration Mode

This mode is normally used only when the instrument is configured for the first time or when a major change is made to the controller characteristics. The Configuration Mode parameters must be set as required before adjusting parameters in Setup Mode, or attempting to use the instrument in an application.

8.1.1 Entry into the Configuration Mode

CAUTION:

Adjustments to these parameters should only be performed by personnel competent and authorised to do so.

Configuration is entered from Select Mode

Hold down  and press  to force the controller into the Select Mode.

then

Press  or  to navigate to the Configuration Mode option, then press .

Note:

Entry into this mode is security-protected by the Configuration Mode Lock Code.



8.1.2 Scrolling Through Parameters and Values

Press  to scroll through the parameters (parameters are described below).

Note:

Only parameters that are applicable to the hardware options chosen will be displayed.

8.1.3 Changing the Parameter Value

Press  to navigate to the required parameter, then press  or  to set the value as required.

Once the value is changed, the display will flash to indicate that confirmation of the change is required. The value will revert back if not confirmed within 10 seconds.

Press  to accept the change.

Or

Press  to reject the change and to move onto the next parameter.

Hold down  and press  to return to Select Mode.

Note:

If there is no key activity for 2 minutes the instrument returns to the operator mode.

Table 10. , 8100 & 4100 Configuration Mode Parameters

Parameter	Lower Display	Upper Display	Description	Default	When Visible
Input type and Range	InPt	bC	B type: 100 to 1824 °C	JC for Europe	Always
		bF	B type: 211 to 3315 °F		
		CC	C type: 0 to 2320 °C	JF for USA	
		CF	C type: 32 to 4208 °F		
		JC	J type: -200 to 1200 °C		
		JF	J type: -328 to 2192 °F		
		J.C	J type: -128.8 to 537.7 °C with decimal point		
		J.F	J type: -199.9 to 999.9 °F with decimal point		
		KC	K type: -240 to 1373 °C		
		KF	K type: -400 to 2503 °F		
		K.C	K type: -128.8 to 537.7 °C with decimal point		
		K.F	K type: -199.9 to 999.9 °F with decimal point		
		LC	L type: 0 to 762 °C		
		LF	L type: 32 to 1403 °F		
L.C	L type: 0.0 to 537.7 °C with decimal point				
L.F	L type: 32.0 to 999.9 °F with decimal point				

Parameter	Lower Display	Upper Display	Description	Default	When Visible
		<i>nC</i>	N type: 0 to 1399 °C		
		<i>nF</i>	N type: 32 to 2551 °F		
		<i>rC</i>	R type: 0 to 1759 °C		
		<i>rF</i>	R type: 32 to 3198 °F		
		<i>sC</i>	S type: 0 to 1762 °C		
		<i>sF</i>	S type: 32 to 3204 °F		
		<i>tC</i>	T type: -240 to 400 °C		
		<i>tF</i>	T type: -400 to 752 °F		
		<i>t.C</i>	T type: -128.8 to 400.0 °C with decimal point		
		<i>t.F</i>	T type: -199.9 to 752.0 °F with decimal point		
		<i>P24C</i>	PtRh20% vs PtRh40%: 0 to 1850 °C		
		<i>P24F</i>	PtRh20% vs PtRh40%: 32 to 3362 °F		
		<i>PtC</i>	Pt100: -199 to 800 °C		
		<i>PtF</i>	Pt100: -328 to 1472 °F		
		<i>Pt.C</i>	Pt100: -128.8 to 537.7 °C with decimal point		
		<i>Pt.F</i>	Pt100: -199.9 to 999.9 °F with decimal point		
		<i>0_20</i>	0 to 20mA DC		
		<i>4_20</i>	4 to 20mA DC		
		<i>0_50</i>	0 to 50mV DC		
		<i>10_50</i>	10 to 50mV DC		
		<i>0_5</i>	0 to 5V DC		
		<i>1_5</i>	1 to 5V DC		
		<i>0_10</i>	0 to 10V DC		
		<i>2_10</i>	2 to 10V DC		
Scale Range Upper Limit	<i>rUL</i>	Scale Range Lower Limit +100 to Range Max		Linear inputs = 1000 (°C/°F inputs = max range)	Always

Parameter	Lower Display	Upper Display	Description	Default	When Visible
Scale Range Lower Limit	rLL	Range Min. to Scale range Upper Limit - 100		Linear = 0 (°C/°F = range)	Always
Decimal point position	dPos	0	Decimal point position in non-temperature ranges. 0 = XXXX 1 = XXX.X 2 = XX.XX 3 = X.XXX	1	InPt = mV, V or mA
		1			
		2			
		3			
Control Type	CtYP	SnGL	Primary control	SnGL	Always
		duAL	Primary and Secondary control (e.g. for heat & cool)		
Primary Output Control Action	CtrL	rEv	Reverse Acting	rEv	Always
		dir	Direct Acting		
Alarm 1 Type	ALA1	P_H1	Process High Alarm	P_H1	Always
		P_Lo	Process Low Alarm		
		dE	Deviation Alarm		
		bAnd	Band Alarm		
		nonE	No alarm		
Process High Alarm 1 value*	PhA1	Range Min. to Range Max. <i>Parameter repeated in Setup Mode</i>		Range Max.	ALA1 = P_H1
Process Low Alarm 1 value*	PLA1	Range Min. to Range Max. <i>Parameter repeated in Setup Mode</i>		Range Min.	ALA1 = P_Lo
Deviation Alarm 1 Value*	dAL1	±span from setpoint <i>Parameter repeated in Setup Mode</i>		5	ALA1 = dE
Band Alarm 1 value*	bAL1	1 LSD to full span from setpoint. <i>Parameter repeated in Setup Mode</i>		5	ALA1 = bAnd
Alarm 1 Hysteresis*	AHY1	1 LSD to 100% of span (in display units) on "safe" side of alarm point. <i>Parameter repeated in Setup Mode</i>		1	Always
Alarm 2 Type	ALA2	As for alarm 1 type		P_Lo	Always
Process High Alarm 2 value*	PhA2	Range Min. to Range Max. <i>Parameter repeated in Setup Mode</i>		Range Max.	ALA2 = P_H1
Process Low Alarm 2 value*	PLA2	Range Min. to Range Max. <i>Parameter repeated in Setup Mode</i>		Range Min.	ALA2 = P_Lo
Deviation Alarm 2 Value*	dAL2	±span from setpoint. <i>Parameter repeated in Setup Mode</i>		5	ALA2 = dE
Band Alarm 2 value*	bAL2	1 LSD to full span from setpoint. <i>Parameter repeated in Setup Mode</i>		5	ALA2 = bAnd

Parameter	Lower Display	Upper Display	Description	Default	When Visible
Alarm 2 Hysteresis*	AHY2		1 LSD to 100% of span (in display units) on “safe” side of alarm point. <i>Parameter repeated in Setup Mode</i>	1	Always
Loop Alarm Enable	LAEn		dISA (disabled) or EnAb (enabled)	dISA	Always
Loop Alarm Time*	LAEt		1 sec to 99 mins. 59secs Only applies if primary proportional band = 0	99.59	LAEn = EnAb
Alarm Inhibit	inh	nonE	No alarms Inhibited	nonE	Always
		AL1	Alarm 1 inhibited		
		AL2	Alarm 2 inhibited		
		both	Alarm 1 and alarm 2 inhibited		
Output 1 Usage	USE 1	Pr	Primary Power	Pr	OPn 1 is not nonE
		SEc	Secondary Power		Not linear
		A1_d	Alarm 1, Direct Acting		Not linear
		A1_r	Alarm 1, Reverse Acting		Not linear
		A2_d	Alarm 2, Direct Acting		Not linear
		A2_r	Alarm 2, Reverse Acting		Not linear
		LP_d	Loop Alarm, Direct Acting		Not linear
		LP_r	Loop Alarm, Reverse Acting		Not linear
		Or_d	Logical Alarm 1 OR Alarm 2 Direct Acting		Not linear
		Or_r	Logical Alarm 1 OR Alarm 2 Reverse Acting		Not linear
		Ar_d	Logical Alarm 1 AND Alarm 2, Direct Acting		Not linear
		Ar_r	Logical Alarm 1 AND Alarm 2, Reverse Acting		Not linear
		rEtS	Retransmit SP Output		Linear only
		rEtP	Retransmit PV Output		Linear only
Linear Output 1 Range	tYP 1	0_5	0 to 5 V DC output 1	0_10	OPn 1 = Lin
		0_10	0 to 10 V DC output		
		2_10	2 to 10 V DC output		
		0_20	0 to 20 mA DC output		
		4_20	4 to 20 mA DC output		

Parameter	Lower Display	Upper Display	Description	Default	When Visible
Retransmit Output 1 Scale maximum	ro1H	- 1999 to 9999 Display value at which output will be maximum		Range max	USE1 = rEt
Retransmit Output 1 Scale minimum	ro1L	- 1999 to 9999 Display value at which output will be minimum		Range min	USE1 = rEt
Output 2 Usage	USE2	As for output 1		SEc if dual control selected else A2_d	OPn2 is not nonE
Linear Output 2 Range	tYP2	As for output 1		0_10	OPn2 = Lin
Retransmit Output 2 Scale maximum	ro2H	- 1999 to 9999 Display value at which output will be maximum		Range max	USE2 = rEt
Retransmit Output 2 Scale minimum	ro2L	- 1999 to 9999 Display value at which output will be minimum		Range min	USE2 = rEt
Output 3 Usage	USE3	As for output 1		A1_d	OPn3 is not nonE
Linear Output 3 Range	tYP3	As for output 1		0_10	OPn3 = Lin
Retransmit Output 3 Scale maximum	ro3H	- 1999 to 9999 Display value at which output will be maximum		Range max	USE3 = rEt
Retransmit Output 3 Scale minimum	ro3L	- 1999 to 9999 Display value at which output will be minimum		Range min	USE3 = rEt
Display Strategy	dISP	1, 2, 3, 4, 5 or 6 (see Operator Mode)		1	Always
Comms Protocol	Prot	ASC1	ASCII	r7bn	OPnA = r4B5
		r7bn	Modbus with no parity		
		r7bE	Modbus with Even Parity		
		r7bo	Modbus with Odd Parity		

Parameter	Lower Display	Upper Display	Description	Default	When Visible
Bit rate	<i>bAud</i>	<i>1.2</i>	1.2 kbps	4.8	<i>OPnA</i> = <i>r485</i>
		<i>2.4</i>	2.4 kbps		
		<i>4.8</i>	4.8 kbps		
		<i>9.6</i>	9.6 kbps		
		<i>19.2</i>	19.2 kbps		
Communications Address	<i>Addr</i>	<i>1</i>	Unique address assigned to the instrument in the range of 1 to 255 (Modbus), 1 to 99 (Ascii)	1	<i>OPnA</i> = <i>r485</i>
Communications Write Enable	<i>CoEn</i>	<i>r_0</i> read only or <i>r_LU</i> read/ write		<i>r_LU</i>	Always
Digital Input 1 Usage	<i>d i01</i>	<i>d i51</i>	Setpoint 1 / Setpoint 2 Select**	<i>d i51</i>	<i>OPnA</i> = <i>d i01</i>
		<i>d iAS</i>	Automatic / Manual Select**		
Digital Input 2 Usage	<i>d i02</i>	<i>d i51</i>	Setpoint 1 / Setpoint 2 Select**	<i>d iR5</i>	<i>OPnb</i> = <i>rSP1</i>
		<i>d iAS</i>	Automatic / Manual Select**		
		<i>d iR5</i>	Remote / Local Setpoint Select		
Remote Setpoint Input Range	<i>rSP1</i>	<i>0_20</i>	0 to 20mA DC input	<i>0_10</i>	<i>OPnA</i> or <i>OPnb</i> = <i>rSP1</i>
		<i>4_20</i>	4 to 20mA DC input		
		<i>0_10</i>	0 to 10V DC input		
		<i>2_10</i>	2 to 10V DC input		
		<i>0_5</i>	0 to 5V DC input		
		<i>1_5</i>	1 to 5V DC input		
		<i>100</i>	0 to 100mV DC input		
		<i>Pot</i>	Potentiometer ($\geq 2K\Omega$)		
Remote Setpoint Upper Limit	<i>rSPu</i>	- 1999 to 9999 RSP value when RSP input is maximum		Range max	<i>OPnA</i> = <i>rSP1</i>
Remote Setpoint Lower Limit	<i>rSPL</i>	- 1999 to 9999 RSP value when RSP input is minimum		Range min	<i>OPnA</i> = <i>rSP1</i>
Remote Setpoint Offset	<i>rSPo</i>	Offset applied to RSP value. Constrained within Scale Range Upper Limit and Scale Range Lower Limit.		0	<i>OPnA</i> = <i>rSP1</i>

Parameter	Lower Display	Upper Display	Description	Default	When Visible
Configura- tion Mode Lock Code	[Loc	0 to 9999		20	Always

***Note:**

*Alarm parameters marked * are repeated in Setup Mode.*

****Note:**

*If **d 1 1** or **d 1 2 = d 5 1** the remote setpoint input feature is disabled. The instrument uses the two internal setpoints (SP1 & SP2) instead.*

*If **d 1 1** and **d 1 2** are set to the same value, the status of digital input 2 will take precedence over digital input 1.*

8.2 P6100, P8100 (AIC 801) & P4100 – Setup Mode

This mode is normally selected only after Configuration Mode has been completed, and is used when a change to the process set up is required. It can affect the range of adjustments available in Operator Mode. Using the PC Configurator software, it is possible to configure an Extended Operator Mode. Setup Mode parameters are moved into Operator Mode, and these parameters appear after the normal Operator Mode screen sequence has been completed.

Note:

Entry into Setup Mode is security-protected by the Setup Mode lock code.

8.2.1 Entry into the Setup Mode



Hold down  and press  to enter the Select Mode

Press  or  to navigate to the Setup Mode option, then press  to enter Setup Mode.

8.2.2 Scrolling Through Parameters & Values

Press  to scroll through the parameters (refer to the table below) and their values.

8.2.3 Changing the Parameter

Press  to select the required parameter, then press  or  to set the value as required.

Once the displayed value is changed the effect is immediate. No confirmation of the change is required.

Note:

If there is no key activity for two minutes the instrument returns to the operator mode.

Table 11. 8100 & 4100 Set Up Mode Parameters

Parameter	Lower Display	Upper Display Adjustment Range	Default	When Visible
Input Filter Time constant	FILT	OFF, 0.5 to 100.0 secs in 0.5 sec increments	2.0	Always
Process Variable Offset	OFFS	±Span of controller	0	Always
Primary Power	PPUJ	The current Primary Output Power. Read Only.	N/A	Always
Secondary Power	SPLJ	The current Secondary Output power. Read Only.	N/A	CTYP = dUAL
Primary Output Proportional Band	Pb_P	0.0% (ON/OFF control) and 0.5% to 999.9% of input span.	10.0	Always
Secondary Output Proportional Band	Pb_S	0.0% (ON/OFF control) and 0.5% to 999.9% of input span.	10.0	CTYP = dUAL
Automatic Reset (Integral Time Constant)	RrSt	1 sec to 99 mins 59 secs and OFF	5.00	Pb_P is not 0.0
Rate (Derivative Time Constant)	rAtE	00 secs to 99 mins 59 secs	1.15	Pb_P is not 0.0
Overlap/Deadband	OL	-20% to +20% of the sum of the Primary and Secondary Proportional Bands	0	Pb_P is not 0.0
Manual Reset (Bias)	bIAS	0% to 100% (-100% to 100% if CTYP = dUAL)	25	Pb_P is not 0.0
Primary Output ON/OFF Differential	dIFP	0.1% to 10.0% of input span (enter in % span)	0.5	Pb_P = 0.0
Secondary Output ON/OFF Differential	dIFS	0.1% to 10.0% of input span (enter in % span)	0.5	Pb_S = 0.0
Primary and Secondary Output ON/OFF Differential	dIFF	0.1% to 10.0% of input span (enter in % span)	0.5	Pb_P and Pb_S = 0.0
Setpoint Upper Limit	SPUL	Current Setpoint value to Scale Range Maximum	Range Max.	Always
Setpoint Lower limit	SPLL	Scale Range Minimum to current Setpoint value	Range Min	Always
Primary (Heat) Output Upper Power Limit	OPUL	0% to 100% of full power	100	Pb_P is not 0.0
Output 1 Cycle Time	CT1	0.5, 1, 2, 4, 8, 16, 32, 64, 128, 256 or 512 secs. Not applicable to linear outputs	32	USE 1 = Pr I or SEc or bUS

Parameter	Lower Display	Upper Display Adjustment Range	Default	When Visible
Output 2 Cycle Time	CT2	0.5, 1, 2, 4, 8, 16, 32, 64, 128, 256 or 512 secs. Not applicable to linear outputs	32	USE2 = Pr1 , or SEc or buS
Output 3 Cycle Time	CT3	0.5, 1, 2, 4, 8, 16, 32, 64, 128, 256 or 512 secs. Not applicable to linear outputs	32	USE3 = Pr1 , or SEc or buS
Process High Alarm 1 value*	PHA1	Range Min. to Range Max.	Range Max.	ALA1 = P_H1
Process Low Alarm 1 value*	PLA1	Range Min. to Range Max.	Range Min.	ALA1 = P_Lo
Deviation Alarm 1 Value*	dAL1	±span from setpoint	5	ALA1 = dE
Band Alarm 1 value*	bAL1	1 LSD to full span from setpoint.	5	ALA1 = bAnd
Alarm 1 Hysteresis*	AHY1	Up to 100% of span	1	Always
Process High Alarm 2 value*	PHA2	Range Min. to Range Max.	Range Max.	ALA2 = P_H1
Process Low Alarm 2 value*	PLA2	Range Min. to Range Max.	Range Min.	ALA2 = P_Lo
Deviation Alarm 2 Value	dAL2	±span from setpoint	5	ALA2 = dE
Band Alarm 2 value*	bAL2	1 LSD to full span from setpoint.	5	ALA2 = bAnd
Alarm 2 Hysteresis*	AHY2	Up to 100% of span	1	Always
Loop Alarm Time*	LAT1	1 sec to 99 mins. 59secs. Only applies if primary proportional band = 0	99.59	LAEn = EnAb
Auto Pre-tune enable / disable	APt	dISA disabled or EnAb enabled	dISA	Always
Manual Control select enable / disable	PoEn	dISA disabled or EnAb enabled	dISA	Always
Setpoint Select shown in Operator Mode, enable / disable	SSEn	dISA disabled or EnAb enabled	dISA	Slot A or B fitted with RSP module
Setpoint ramp shown in operator mode, enable / disable	SPr	dISA disabled or EnAb enabled	dISA	Always
SP Ramp Rate Value	rP	1 to 9999 units/hour or Off (blank)	Blank	Always

Parameter	Lower Display	Upper Display Adjustment Range	Default	When Visible
Setpoint Value	SP	Within scale range upper and lower limits	Range minimum	Always
Local Setpoint Value	LSP _LSP or ≡LSP	Within scale range upper and lower limits. _ or ≡ before the legend indicates if this is the currently active SP	Range minimum.	OPnA or OPnb = rSP ,
Setpoint 1 Value	SP 1 _SP 1 or ≡SP 1	Within scale range upper and lower limits. _ or ≡ before the legend indicates if this is the currently active SP	Range minimum.	d iG 1 or d iG2 = d iS 1
Setpoint2 Value	SP2 _SP2 or ≡SP2	Within scale range upper and lower limits. _ or ≡ before the legend indicates if this is the currently active SP	Range minimum.	d iG 1 or d iG2 = d iS 1
Set-up Lock Code	SLoc	0 to 9999	10	Always

**First Operator mode displays follows.

Note:

*Alarm parameters marked * are repeated in Configuration Mode.*

Note:

***Once the complete list of Set Up Mode parameters has been displayed, the first Operator Mode display is shown without exiting from Set Up Mode. Display seen is dependant on the Display Strategy and status of Auto/Manual mode selection.*

8.3 P6100, P8100 (AIC 801) & P4100 Controllers - Operator Mode

This is the mode used during normal operation of the instrument. It can be entered from Select Mode, and is the usual mode entered at power-up. The available displays are dependent upon whether Dual or Remote Setpoint modes are being used, whether Setpoint Ramping is enabled and the setting of the Display Strategy parameter in Configuration Mode.

WARNING:

IN NORMAL OPERATION, THE OPERATOR MUST NOT REMOVE THE CONTROLLER FROM ITS HOUSING OR HAVE UNRESTRICTED ACCESS TO THE REAR TERMINALS, AS THIS WOULD PROVIDE POTENTIAL CONTACT WITH HAZARDOUS LIVE PARTS.

CAUTION:



Set all Configuration Mode parameters and Set Up Mode parameters as required before starting normal operations.

8.3.1 8100 & 4100 Controllers – Extended Operator Mode

Using the PC configuration software, it is possible to extend the Operator Mode displays available by adding parameters from Setup Mode. When an extended Operator Mode is configured the additional parameters are available after the standard operator displays.

8.3.2 Navigating in Operator Mode

Press  to move between displays.

When a display value can be adjusted, use  or  to change its value.

Note:

The operator can freely view the parameters in this mode, but alteration depends on the settings in the Configuration and Set Up Modes. All parameters in Display strategy 6 are read only, and can only be adjusted via Setup mode.

Table 12. 8100 & 4100 Operator Mode Displays

Upper Display	Lower Display	When Visible	Description
PV Value	Active SP Value	Display strategy 1 and 2. <i>(Initial Screen)</i>	Process Variable and target value of currently selected Setpoint. <i>Local SP is adjustable in Strategy 2</i>
PV Value	Actual SP Value	Display strategy 3 and 6 <i>(Initial Screen)</i>	Process Variable and actual value of selected Setpoint (e.g. ramping SP value). <i>Read only</i>
PV Value	<i>Blank</i>	Display strategy 4. <i>(Initial Screen)</i>	Shows Process Variable. <i>Read only</i>
Actual SP Value	<i>Blank</i>	Display strategy 5. <i>(Initial Screen)</i>	Shows target value of currently selected Setpoint. <i>Read only</i>

Upper Display	Lower Display	When Visible	Description	
SP Value	SP	Display strategy 1, 3, 4, 5 and 6 if Digital Input is not d 5 1 in config mode and RSP is not fitted	Target value of Setpoint. <i>Adjustable except in Strategy 6</i>	
SP1 Value	SP 1 or _SP 1	If Digital Input is set for dual SP (d 5 1 in config mode).	Target value of Setpoint 1. _SP 1 means SP1 is selected as the active Setpoint. <i>Adjustable except in Strategy 6</i>	
SP2 Value	SP2 or _SP2	If Digital Input is set for dual SP (d 5 1 in config mode).	Target value of Setpoint 2. _SP2 means SP2 is selected as the active Setpoint. <i>Adjustable except in Strategy 6</i>	
Local Setpoint Value	LSP _LSP or ≡LSP	If Remote Setpoint Input is fitted and Digital Input is not d 5 1 in config mode	Target value of Local Setpoint. _LSP means the local setpoint is selected as the active SP (if the digital input has been overridden, the ≡ character is lit instead). <i>Adjustable except in Strategy 6</i>	
Remote Setpoint Value	rSP _rSP or ≡rSP	If Remote Setpoint Input is fitted and Digital Input is not d 5 1 in config mode	Target value of Remote Setpoint. _rSP means the remote setpoint is selected as the active SP (if the digital input has been overridden, the ≡ character is lit instead). <i>Read only</i>	
d 5 1 , LPS or rPS	SPS	If Remote Setpoint Input is fitted, Digital Input is not d 5 1 in config mode and SSEn is enabled in Setup mode	Setpoint Select. Selects between Local or Remote Setpoints. LSP = local SP, rSP = remote SP, d 5 1 = selection via digital input (if configured). <i>Note: LSP or rSP will override the digital input (active SP indication changes to ≡)</i> <i>Adjustable except in Strategy 6</i>	
Actual SP Value	SPrP	If a Ramping Setpoint is in use (rP not <i>Blank</i>).	Actual value of selected Setpoint (e.g. ramping SP value). <i>Read only</i>	
SP Ramp Rate Value	rP	If SPr (ramping SP) is enabled in Setup mode.	Setpoint ramping rate, in units per hour. Set to <i>Blank</i> (higher than 9999) to turn off ramping. <i>Adjustable except in Strategy 6</i>	
Active Alarm Status	ALSt	When any alarm is active.  ALM indicator will also flash	Upper display shows which alarm(s) are active. Inactive alarms are blank	
			1	Alarm 1 Active
			2	Alarm 2 Active
			L	Loop Alarm Active



Note:

When an extended Operator Mode is configured the additional parameters are available after the above parameters. Extended Operator Mode parameters can only be configured using the PC software.

8.4 Adjusting the Local Setpoint(s)

Setpoints can be adjusted within the limits set by the Setpoint Upper and Lower Limit parameters in Setup. Operator Mode adjustment of Setpoint is not possible if Display Strategy 6 has been selected on Configuration Mode.



Press  to select the adjustable setpoint display

Press  or  to adjust the setpoint to the required value.

8.5 Adjusting the Setpoint Ramp Rate

The ramp rate may be adjusted in the range 1 to 9999 and OFF. Increasing the ramp rate value beyond 9999 will cause the upper display to go blank and setpoint ramping to be switched OFF. Setpoint ramping can be resumed by decreasing the ramp rate to 9999 or less.

Press  to select the adjustable setpoint display

Press  or  to adjust the setpoint to the required value.

WARNING:



THE SETPOINT RAMP FEATURE DISABLES THE PRE-TUNE FACILITY. THE SELF-TUNE FACILITY WILL COMMENCE ONLY AFTER THE SETPOINT HAS COMPLETED THE RAMP.

8.6 Manual Control Mode

To allow manual control to be selected in Operator Mode, **PoEn** must be enabled in Set Up Mode. The MAN indicator will flash continually in Manual Mode.

8.6.1 Selecting/deselecting Manual Control Mode

Press the  key to toggle between Automatic and Manual control.

Press  or  to adjust the output power to the required value.

CAUTION:

The Manual Mode power level can be adjusted from 0 to 100% (-100 to +100% for dual output). It is not restricted by the Output Power Limit parameter **OPuL.**

Note:

*Disabling **PoEn** in Set Up Mode whilst manual control mode is active will lock the controller into manual mode. Pressing the Auto/Man key will no longer cause a return to automatic control. To exit from Manual Mode, **PoEn** must temporarily be re-enabled.*

9 Manual Tuning Controllers

9.1 Controllers Fitted With Primary Output Only

Before starting to tune a controller, check that the Setpoint Upper Limit (**SPUL**) and Setpoint Lower Limit (**SPLL**) are set to safe levels.

The following simple technique may be used to determine values for the Primary Proportional Band (**Pb_P**), Integral Time Constant (**ArSt**) and Derivative Time Constant (**rAtE**).

CAUTION:

This technique is suitable only for processes that are not harmed by large fluctuations in the process variable. It provides an acceptable basis from which to start fine-tuning for a wide range of processes.

1. Set the setpoint to the normal operating process value (or to a lower value if overshoot beyond this value is likely to cause damage).
2. Select On-Off control (i.e. set **Pb_P** = 0).
3. Switch on the process. The process variable will oscillate about the setpoint. Note (a) the Peak-to-Peak variation (P) of the first cycle i.e. the difference between the highest value of the first overshoot and the lowest value of the first undershoot, and (b) the time period of the oscillation (T) in minutes. See the example diagram below - Manual Tuning.
4. The PID control parameters should then be set as follows:

$$\begin{aligned}
 \mathbf{Pb_P} &= \frac{\mathbf{P}}{\mathbf{Input\ Span}} \times 100 \\
 \mathbf{ArSt} &= \mathbf{T} \text{ minutes} \\
 \mathbf{rAtE} &= \frac{\mathbf{T}}{6} \text{ minutes}
 \end{aligned}$$

Note:

After setting up the parameters, return the controller to operator mode to prevent unauthorised adjustment of the values.

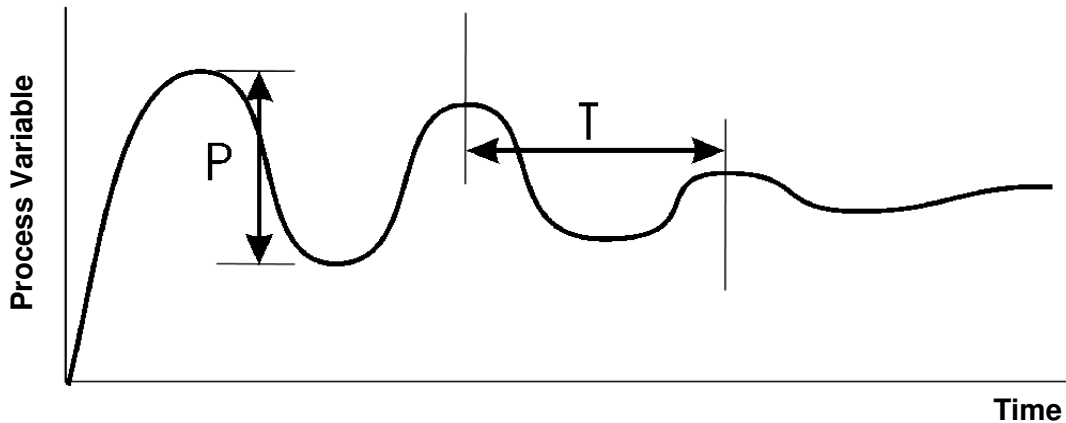

Figure 39. Manual Tuning

9.2 Controllers Fitted With Primary and Secondary Outputs

Before starting to tune a controller, check that the Setpoint Upper Limit (**SPUL**) and Setpoint Lower Limit (**SPLL**) are set to safe levels.

The following simple technique may be used to determine values for the Primary Proportional Band (**Pb_P**), Secondary Proportional Band (**Pb_S**), Integral Time Constant (**ArSt**) and Derivative Time Constant (**rAtE**).

CAUTION:

This technique is suitable only for processes that are not harmed by large fluctuations in the process variable. It provides an acceptable basis from which to start fine-tuning for a wide range of processes.

1. Tune the controller using only the Primary Control output as described in the previous section.
2. Set **Pb_S** to the same value as **Pb_P** and monitor the operation of the controller in dual output mode. If there is a tendency to oscillate as the control passes into the Secondary Proportional Band, increase the value of **Pb_S**. If the process appears to be over-damped in the region of the Secondary Proportional Band, decrease the value of **Pb_S**.
3. When the PID tuning term values have been determined, if there is a kick to the process variable as control passes from one output to the other, set the Overlap/Deadband parameter to a positive value to introduce some overlap. Adjust this value by trial and error until satisfactory results are obtained.

9.3 Manual Fine Tuning.

A separate cycle time adjustment parameter is provided for each time proportioning control output.

Note:

Adjusting the cycle time affects the controllers operation; a shorter cycle time gives more accurate control but electromechanical components such as relays have a reduced life span.

1. Increase the width of the proportional band if the process overshoots or oscillates excessively.
2. Decrease the width of the proportional band if the process responds slowly or fails to reach setpoint.
3. Increase the automatic reset until the process becomes unstable, then decrease until stability has been restored.

Note:

Allow enough time for the controller and process to adjust.

4. Initially add rate at a value between $1/4^{\text{th}}$ and $1/10^{\text{th}}$ of the automatic reset value.
5. Decrease Rate if the process overshoots/undershoots or oscillates excessively.

Note:

Rate can cause process instability.

6. After making all other adjustments, if an offset exists between the setpoint and the process variable use the Bias (manual reset) to eliminate the error:

Below setpoint - use a larger bias value.

Or

Above setpoint - use a smaller bias value.

10 Modbus Serial Communications

All models support the Modbus RTU communication protocol. Some models also support an ASCII communication protocol. Where both Modbus and ASCII are supported, the protocol to be used is selected from Configuration Mode. The RS485 Communications Module must be fitted into Option Slot A in order to use serial communications.

A full description of the parameters available is provided in the Application Layer section.

For a complete description of the Modbus protocol refer to the description provided at <http://www.modicon.com/> or <http://www.modbus.org/>

10.1 Physical Layer

The Base address, bit rate and character format are configured via the front panel in Configuration Mode or by using the PC Configurator software.

Physical layer configuration settings possible are:

Data rate: 1200, 2400, 4800 (default), 9600 and 19,200 bps

Parity: None (default), Even, Odd

Character format: Always 8 bits per character.

The transmitter must not start transmission until 3 character times have elapsed since reception of the last character in a message, and must release the transmission line within 3 character times of the last character in a message.

Note:

Three character times = 1.5ms at 19200, 3ms at 9600, 6ms at 4800, 12ms at 2400 and 24ms at 1200 bps.

10.2 Link Layer

A Query (or command) is transmitted from the Modbus Master to the Modbus Slave. The slave instrument assembles the reply to the master. All of the instruments covered by this manual are slave devices, and cannot act as a Modbus Master.

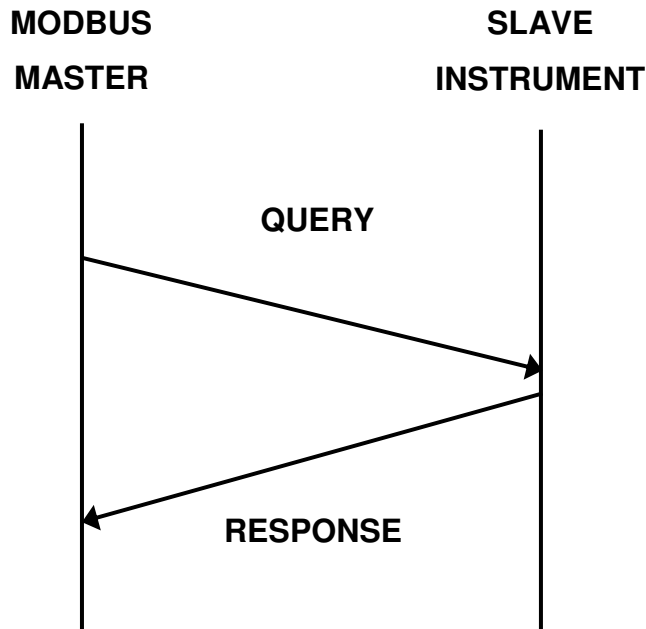

Figure 40. Link Layer

A message for either a QUERY or RESPONSE is made up of an inter-message gap followed by a sequence of data characters. The inter-message gap is at least 3.5 data character times.

Data is encoded for each character as binary data, transmitted LSB first.

For a QUERY the address field contains the address of the slave destination. The slave address is given together with the Function and Data fields by the Application layer. The CRC is generated from the given address, function and data characters.

For a RESPONSE the address field contains the address of the responding slave. The Function and Data fields are generated by the slave application. The CRC is generated from the address, function and data characters.

The standard MODBUS RTU CRC-16 calculation employing the polynomial $2^{16}+2^{15}+2^2+1$ is used.

Inter-message gap	Address 1 character	Function 1 character	Data <i>n</i> characters	CRC Check 2 characters
-------------------	------------------------	-------------------------	-----------------------------	---------------------------

10.3 Device Addressing

The instrument is assigned a unique device address by the user in the range 1 (default) to 255 using the *Addr* parameter in Configuration Mode. This address is used to recognise Modbus Queries intended for this instrument. The instrument does not respond to Modbus Queries that do not match the address that has been assigned to it.

The instrument will also accept global Queries using device address 0 no matter what device address is assigned. No responses are returned for globally addressed Queries.

10.4 Supported Modbus Functions

Modbus defines several function types; these instruments support the following types:

Table 13. Supported Modbus Functions

Function Code (decimal)	Modbus Meaning	Description
01 / 02	Read Coil/Input Status	Read output/input status bits at given address.
03 / 04	Read Holding/Input registers	Read current binary value of specified number of parameters at given address. Up to 64 parameters can be accessed with one Query.
05	Force single Coil	Writes a single binary bit to the Specified Slave Bit address.
06	Pre-set Single Register	Writes two bytes to a specified word address.
08	Diagnostics	Used for loopback test.
16	Pre-set Multiple Registers	Writes up to 1 word parameter values to the specified address range.

10.5 Function Descriptions

The following is interpreted from the Modbus Protocol Description obtainable from <http://www.modicon.com/> or <http://www.modbus.org/>. Refer to that document if clarification is required.

In the function descriptions below, the preceding device address value is assumed, as is the correctly formed two-byte CRC value at the end of the QUERY and RESPONSE frames.

10.5.1 Read Coil/Input Status (Function 01 / 02)

Reads the content of instruments output/input status bits at the specified bit address.

Table 14. Read Coil/Input Status (Function 01/02)

QUERY

Function	Address of 1st Bit		Number of Bits	
01 / 02	HI	LO	HI	LO

RESPONSE

Function	Number of Bytes	First 8 bits	2nd 8 Bits
01 / 02			

In the response the “Number of Bytes” indicates the number of data bytes read from the instrument. E.g. if 16 bits of data are returned then the count will be 2. The maximum number of bits that can be read is 16 in one transaction. The first bit read is returned in the least significant bit of the first 8 bits returned.

10.5.2 Read Holding/Input Registers (Function 03 / 04)

Reads current binary value of data at the specified word addresses.

Table 15. Read Holding/Input Registers (Function 03/04)

QUERY

Function	Address of 1 st Word		Number of Words	
03 / 04	HI	LO	HI	LO

RESPONSE

Function	Number of Bytes	First Word		Last Word	
03 / 04		HI	LO	HI	LO

In the response the “Number of Bytes” indicates the number of data bytes read from the instrument. E.g. if 5 words are read, the count will be 10 (A hex). The maximum number of words that can be read is 64. If a parameter does not exist at one of the addresses read, then a value of 0000h is returned for that word.

10.5.3 Force Single Coil (Function 05)

Writes a single binary value to the Specified Instrument Bit address.

Table 16. Force Single Coil (Function 05)

QUERY

Function	Address of Bit		State to write	
05	HI	LO	FF/00	00

RESPONSE

Function	Address of Bit		State written	
05	HI	LO	FF/00	00

The address specifies the address of the bit to be written to. The State to write is FF when the bit is to be SET and 00 if the bit is to be RESET.

Note:

The Response normally returns the same data as the Query.

10.5.4 Pre-Set Single Register (Function 06)

Writes two bytes to a specified word address.

Table 17. Pre-Set Single Register (Function 06)

QUERY

Function	Address of Word		Value to write	
06	HI	LO	HI	LO

RESPONSE

Function	Address of Word		Value written	
06	HI	LO	HI	LO

Note:

The Response normally returns the same data as the Query.

10.5.5 Loopback Diagnostic Test (Function 08)

Table 18. Loopback Diagnostic Test (Function 08)

QUERY

Function	Diagnostic Code		Value	
08	HI =00	LO=00	HI	LO

RESPONSE

Function	Sub-function		Value	
08	HI=00	LO=00	HI	LO

Note:

The Response normally returns the same data as the Query.

10.5.6 Pre-Set Multiple Registers (Function 10 Hex)

Writes a consecutive word (two-byte) value to the specified address range.

Table 19. Pre-Set Multiple Registers (Function 10 Hex)

QUERY							
Function	1 st Word Address		Number of Words		Number of Query Bytes	First value to write	
10	HI	LO	HI	LO		HI	LO

RESPONSE				
Function	1st Word Address		Number of Words	
10	HI	LO	HI	LO

Note:

The number of consecutive words that can be written is limited to 1.

10.5.7 Exception Responses

When a QUERY is sent that the instrument cannot interpret then an Exception RESPONSE is returned. Possible exception responses are:

Table 20. Exception Responses

Exception Code	Error Condition	Interpretation
00	Unused	None.
01	Illegal function	Function number out of range.
02	Illegal Data Address	Write functions: Parameter number out of range or not supported. (for write functions only). Read Functions: Start parameter does not exist or end parameter greater than 65536.
03	Illegal Data Value	Attempt to write invalid data / required action not executed.

The format of an exception response is:

RESPONSE	
Function	Exception Code
Original Function code with ms bit set.	as detailed above

Note:

In the case of multiple exception codes for a single QUERY the Exception code returned is the one corresponding to the first parameter in error.

11 ASCII Communications

This is a simple ASCII protocol that provides backwards compatibility with previous generations of products. ASCII is not available in all models in the range. The Modbus protocol is recommended for future use.

11.1 Physical Layer

The Base address, bit rate and character format are configured via the front panel in Configuration Mode or by using the PC configurator software.

Physical layer configuration settings possible are:

Data rate: 1200, 2400, 4800 (default), 9600 and 19,200 bps
 Parity: Even
 Character format: 7 bits per character. + 1 stop bit.

The transmitter must not start transmission until 3 character times have elapsed since reception of the last character in a message, and must release the transmission line within 3 character times of the last character in a message.

Note:

Three character times = 1.5ms at 19200, 3ms at 9600, 6ms at 4800, 12ms at 2400 and 24ms at 1200 bps.

11.2 Device Addressing

The instrument is assigned a device address by the user using the *Addr* parameter in Configuration Mode. The address may be set to any unique value from 1 (default) to 99. This address is used to recognise ASCII messages intended for this instrument. The instrument does not respond to messages that do not match the address that has been assigned to it.

11.3 Session Layer

The ASCII protocol assumes half duplex communications. The master device initiates all communication. The master sends a command or query to the addressed slave instrument and the slave replies with an acknowledgement of the command or the reply to the query.

Messages from the master device may be one of five types:

Type 1: {S}{N}??*
Type 2: {S}{N}{P}{C}* or R{N}{P}{C}*
Type 3: {S}{N}{P}#{DATA}* or R{N}{P}#{DATA}*
Type 4: {S}{N}{P}!* or R{N}{P}!*
Type 5: {S} {N} \ P S S ? *

All characters are in ASCII code. See the following Parameter Key table for details of the parameters in brackets { }.

Table 21. Parameter Key

{S}	is the Start of Message character L (Hex 4C) or R (Hex 52). L is used for Controllers; R is used for Profilers.
{N}	is the slave device address (in the range 1 - 99); addresses 1 - 9 may be represented by a single digit (e.g. 7) or in two-digit form, the first digit being zero (e.g. 07).
{P}	is a character which identifies the parameter to be interrogated/modified.
{C}	is the command (Refer to 13 - Application Layer)
#	indicates that {DATA} is to follow (Hex 23)
{DATA}	is a string of numerical data in ASCII code (refer to the Data Element table below)
P	is the Program Number
SS	is the Segment Number (01 to 16)
*	is the End of Message Character (Hex 2A)

No space characters are permitted in messages. Any syntax errors in a received message will cause the slave instrument to issue no reply and await the Start of Message character.

Table 22. Data Element – Sign/Decimal Point Position

{DATA} Content	Data Format	Description
abcd0	+abcd	Positive value, no decimal place
abcd1	+abc.d	Positive value, one decimal place
abcd2	+ab.cd	Positive value, two decimal places
abcd3	+a.bcd	Positive value, three decimal places
Abcd5	- abcd	Negative value, no decimal place
Abcd6	- abc.d	Negative value, one decimal place
Abcd7	- ab.cd	Negative value, two decimal places
Abcd8	- a.bcd	Negative value, three decimal places

(in the Data Content, abcd represents the data value, the last digit indicates data format)

11.3.1 Type 1 Message

L {N} ? ? *

This message is used by the master device to determine whether the addressed slave device is active.

The reply from an active slave is

L {N} ? A *

An inactive device will give no reply.

11.3.2 Type 2 Message

L {N} {P} {C} * or R {N} {P} {C} *

This type of message is used by the master device, to interrogate or modify a parameter in the addressed slave device. **{P}** identifies the parameter and **{C}** represents the command to be executed, which may be one of the following:

- + (Hex 2B) = Increment the value of the parameter defined by **{P}**
- (Hex 2D) = Decrement the value of the parameter defined by **{P}**
- ? (Hex 3F) = Determine the current value of the parameter defined by **{P}**

The reply from the addressed slave device is of the form:

L {N} {P} {DATA} A * or R {N} {P} {DATA} A *

where **{DATA}** comprises five ASCII-coded digits whose format is shown in the Data Element table above. The data is the value requested in a query message or the new value of the parameter after modification. If the action requested by the message from the master device would result in an invalid value for that parameter (either because the requested new value would be outside the permitted range for that parameter or because the parameter is not modifiable), the slave device replies with a negative acknowledgement:

L {N} {P} {DATA} N * or R {N} {P} {DATA} N *

The **{DATA}** string in the negative acknowledgement reply will be indeterminate. If the process variable or the deviation is interrogated whilst the process variable is outside the range of the slave device, the reply is:

L {N} {P} < ? ? > 0 A *

if the process variable is over-range, or

L {N} {P} < ? ? > 5 A *

if the process variable is under-range.

11.3.3 Scan Tables

A parameter identifier character “]” in the message from the master device indicates that a “Scan Table” operation is required. The Scan Table provides a facility for interrogating the values of a group of parameters and status in a single message from the master device. The reply to such a command would be in the form:

L {N}] xx aaaaa bbbbb ccccc ddddd eeeee A *

For the Controller Scan Table response, **xx** is the number of **{data}** digits to follow; this is 20 for a single control-output instrument and 25 for a dual control-output instrument.

These digits are as described in Tables 23 and 24

Table 23. Standard scan table

aaaaa	= The current setpoint value
bbbbb	= The current process variable value
ccccc	= The current value of Output 1 Power (0 - 100%)
dddd	= The current value of Output 2 Power (0 - 100%), if applicable.
eeeee	= The Controller Status

Table 24. VMD control mode scan table

aaaaa	= The current setpoint value
bbbbb	= The current process variable value
ccccc	= The current valve movement
dddd	= The Controller Status

11.3.4 Type 3 Message

L {N} {P} # {DATA} * or R {N} {P} # {DATA} *

This message type is used by the master device to set a parameter to the value specified in **{DATA}**. The command is not implemented immediately by the slave device; the slave will receive this command and will then wait for a Type 4 message (see below). Upon receipt of a Type 3 message, if the **{DATA}** content and the specified parameter are valid, the slave device reply is of the form:

L {N} {P} {DATA} I * or R {N} {P} {DATA} I *

(where **I** = Hex 49) indicating that the slave device is ready to implement the command. If the parameter specified is invalid or is not modifiable or if the desired value is outside the permitted range for that parameter, the slave device replies with a negative acknowledgement in the form:

L {N} {P} {DATA} N * or R {N} {P} {DATA} N *

11.3.5 Type 4 Message

L {N} {P} I * or R {N} {P} I *

This type of message is sent by the master device to the addressed slave device, following a successful Type 3 transaction with the same slave device. Provided that the **{DATA}** content and the parameter specified in the preceding Type 3 message are still valid, the slave device will then set the parameter to the desired value and will reply in the form:

L {N} {P} {DATA} A *

where **{DATA}** is the new value of the parameter. If the new value or parameter specified is invalid, the slave device will reply with a negative acknowledgement in the form:

L {N} {P} {DATA} N *

where **{DATA}** is indeterminate. If the immediately preceding message received by the slave device was not a Type 3 message, the Type 4 message is ignored.

11.4 Error Response

The circumstances under which a message received from the master device is ignored are:

- Parity error detected
- Syntax error detected
- Timeout elapsed
- Receipt of a Type 4 message without a preceding Type 3 command message.

Negative acknowledgements will be returned if, in spite of the received message being notionally correct, the slave device cannot supply the requested information or perform the requested operation. The **{DATA}** element of a negative acknowledgement will be indeterminate.

12 Application Layer

12.1 Parameters

The Modbus and ASCII parameters address/indents are detailed below. R in the R/W column indicates a read only parameter, R/W indicates that the parameter can be read from or written to.

12.1.1 Bit Parameters

Bit parameters are not applicable to the ASCII protocol.

Table 25. Bit Parameters

Parameter	Modbus Par No.	R/W	Notes
Communication Write Status	1	R	1 = Write Enabled, 0 = Write Disabled
Auto / Manual	2	R/W	1 = Manual Control, 0 = Automatic Control
Self Tune	3	R/W	1 = Activate(d), 0 = Dis-engage(d)
Pre tune	4	R/W	1 = Activate(d), 0 = Dis-engage(d)
Alarm 1 Status	5	R	1 = Active, 0 = Inactive
Alarm 2 Status	6	R	1 = Active, 0 = Inactive
Setpoint Ramp Enable(d)	7	R/W	Non-VMD modes only. 1 = Enable(d), 0 = Disable(d)
Auto Pre tune	7	R/W	VMD modes only. 1 = Enable(d), 0 = Disable(d)
	8	R/W	Reserved
	9	R/W	Reserved
Loop Alarm Status	10	R/W	1 = Active/Enable, 0 = Inactive/Disable
	11	R/W	Reserved
Loop Alarm	12	R/W	Read to get loop alarm status. Write 0/1 to disable/enable.
Digital Input 2	13	R	State of Option B digital input. (RSP models only).
	14	R	Reserved
	15	R	Reserved

12.1.2 Word Parameters

Table 26. Word Parameters

Parameter	Modbus Par. No.	ASCII Ident.	R/W	Notes
Process Variable	1	M	R	Current value of PV.
Setpoint	2	S	R/W	Value of currently selected setpoint. (Target setpoint if ramping). Parameter is read only if the current setpoint is RSP.
Output Power	3	W	R/W	0% to 100% for one output; –100% to +100% for dual output control. Read Only if not in manual control. Not applicable to VMD Output.
Deviation	4	V	R	Value of PV-SP
Secondary Proportional Band	5	U	R/W	Read only if Self-Tuning. Otherwise Read / Write. 0.0% to 999.9% of input span
Primary Proportional Band	6	P	R/W	R/O if Self-Tuning. 0.0% to 999.9% of input span
Direct / Reverse Acting	7		R/W	1 = Direct Acting, 0 = Reverse
Reset (or Loop Alarm Time)	8	I	R/W	Read only if Self-Tuning. Integral Time Constant value or (for ON/OFF control with Loop Alarm Enabled) Loop Alarm Time value ASCII Range: 0secs. to 99mins. 59secs. (99.59) Modbus Range: 0 to 5999
Rate	9	D	R/W	Read only if Self-Tuning. ASCII Range: 0secs. to 99mins. 59secs. (99.59) Modbus Range: 0 to 5999
Output 1 Cycle time	10	N	R/W	Non-VMD controller modes only. Powers of 2 in the range 0.5secs. to 512secs. (0.5, 1, 2, 4 etc).
Motor Travel Time	10	N	R/W	VMD controller mode only
Scale Range Lower Limit	11	H	R/W	Lower limit of scaled input range
Scale Range Upper Limit	12	G	R/W	Upper limit of scaled input range
Alarm 1 Value	13	C	R/W	Alarm 1 active at this level
Alarm 2 Value	14	E	R/W	Alarm 2 active at this level

Parameter	Modbus Par. No.	ASCII Ident.	R/W	Notes
Manual Reset	15	J	R/W	Bias value. 0% to 100% for one output; 100% to +100% for two outputs Not applicable to VMD Output.
Overlap / Deadband	16	K	R/W	20% to +20% of PB.P + PB.S ; Negative value = Deadband Positive value = Overlap Not applicable to VMD Output.
On / Off Differential	17	F	R/W	0.1% to 10.0% of input span Used for Primary output on/off differential and for combined Primary and Secondary on/off differential.
Decimal Point Position	18	Q	R/W	Read only if not Linear Input. 0 = xxxx 1 = xxx.x 2 = xx.xx 3 = x.xxx
Output 2 Cycle Time.	19	O	R/W	Non-VMD controller modes only. Powers of 2 in the range 0.5secs to 512secs (0.5, 1, 2, 4 etc).
Minimum On Time	19	O	R/W	VMD only
Primary Output Power Limit	20	B	R/W	Safety power limit; 0 to 100 %. Not applicable to VMD.
Actual Setpoint	21		R	Current (ramping) value of selected setpoint.
Setpoint Upper Limit	22	A	R/W	Maximum setpoint value. Current SP to Input Range Maximum
Setpoint Lower Limit	23	T	R/W	Minimum value of setpoint
Setpoint Ramp Rate	24	^	R/W	0 = Off, 1 to 9999 increments / hour. DP position as for input range.
Input Filter Time Constant	25	m	R/W	0 to 100 seconds
Process Value Offset	26	v	R/W	Modified PV = Actual PV + PV Offset. Limited by Scale Range Max. and Scale Range Min.
Re-transmit output Max	27	[R/W	Maximum scale value for retransmit output, 1999 to 9999
Re-transmit Output Min	28	\	R/W	Minimum scale value for retransmit output, 1999 to 9999;
Setpoint 2	29		R/W	Value of Setpoint 2
Remote Setpoint	30		R	Value of RSP. Returns 0FFFFhex if RSP not fitted.

Parameter	Modbus Par. No.	ASCII Ident.	R/W	Notes
Remote Setpoint Offset	31		R/W	±span
Alarm 1 Hysteresis	32		R/W	0 to 100% of span
Alarm 2 Hysteresis	33		R/W	0 to 100% of span
Setpoint 1	34		R/W	Value of Setpoint 1
Setpoint Select	35		R	Shows which is the currently selected active setpoint 1 = SP1 or LSP 2 = SP2 100hex = RSP
Controller commands		Z	R/W	Only Type 3 / 4 ASCII messages are allowed with this parameter. The {DATA} field must be one of eight five-digit numbers. The commands corresponding to the {DATA} field value are: 00010 = Activate Manual Control 00020 = Activate Automatic Control 00030 = Activate the Self-Tune 00040 = De-activate the Self-Tune 00050 = Request Pre-Tune 00060 = Abort Pre-Tune 00130 = Activate Loop Alarm 00140 = De-activate Loop Alarm

Parameter	Modbus Par. No.	ASCII Ident.	R/W	Notes	
Controller Status word		L	R	Bit	Meaning
				0	Alarm 1 status. 0 = activated, 1 = safe
				1	Alarm 2 status. 0 = activated, 1 = safe
				2	Self-Tune status. 0 = disabled 1 = activated
				3	Change Indicator. 1 = A parameter other than controller status, PV or Output power has been changed since the last time the status word was read.
				4	Comms write status: 0 = disabled 1 = enabled.
				5	A/M control. 0 = disabled 1 = enabled
				6	Not used.
				7	Pre-tune status. 0 = disabled 1 = enabled.
			8	Loop alarm status. 0 = activated, 1 = safe.	
Scan Table		J	R	Reads main controller parameters. Refer to Scan Tables	
Equipment ID	122		R	The four digit model number	
Serial number Low	123		R	Bits 0 - 15	Serial numbers are in a numeric range of 0 to 9999 9999 9999. These are stored as 12 BCD digits.
Serial number Mid	124		R	Bits 16 - 31	
Serial number High	125		R	Bits 32 - 47	
Date of manufacture	126		R	Manufacturing date code as an encoded binary number. E.g. 0403 for April 2003 is returned as 193hex	
Product Revision Level	129		R	Refer to Product Revision Level	
Firmware Version	130		R	Refer to Firmware Version	
Universal Input status	133		R	Input status. Read Only. Bit 0: Sensor break flag Bit 1: Under-range flag Bit 2: Over-range flag	

Parameter	Modbus Par. No.	ASCII Ident.	R/W	Notes
Database ID	134		R	Database ID value. This is a unique number to identify the parameter list for this product. It is used by the configurator software to check recipe and database compatibility. A new ID is assigned for each revision of the parameter database for a given product. Database ID values assigned are: P6100+ = 0

Note:

Some of the parameters that do not apply to a particular configuration (e.g. Secondary Proportional Band on a single output controller) will accept reads and writes. Others are read only, and will return an exception if an attempt is made to write values to them.

12.2 Additional Parameter Details

This section gives communications parameters that provide information about the instrument.

12.2.1 Communications Write Enable

Parameters may be read at any time but may be written only if the Communications Write parameter is enabled. A negative acknowledgement (exception code 3) will be sent to write commands if communications writes are not enabled.

12.2.2 Equipment ID

This read only word parameter returns the binary coded four digit model number of the base model of the product. This is a read only parameter.

12.2.3 Date of Manufacture

This word read only parameter returns the date of manufacture. It is encoded as a binary number (e.g. 0403 for April 2003 is returned as 193hex). This is a read only parameter.

12.2.4 Product Revision Level

This word read-only parameter returns the Product revision level code as an encoded binary number. It can only be written by the use of manufacturing diagnostics.

Low byte: Binary number corresponding to Alpha part of PRL. E.g. A = 01hex

High byte: Binary number corresponding to numeric part of PRL. E.g. 13 = 0Dhex

A Product revision level of 13A will be returned as 0D01hex.

12.2.5 Firmware Version

This word read only parameter returns the firmware version number as an encoded binary number.

Table 27. Firmware Version

Bits	Meaning
0 - 4	Revision number (1,2...)
5 - 9	Alpha version (A=0, B=1...)
10 - 15	Numeric version (starting from 121 = 0)

13 Calibration Mode

WARNING:

CALIBRATION IS ONLY REQUIRED FOR INSTRUMENTS IN WHICH CALIBRATION ERRORS HAVE BEEN ENCOUNTERED. REFER TO CALIBRATION CHECK BELOW.

CAUTION:

Calibration must be performed by personnel who are technically competent and authorised to do so.

Calibration is carried out during manufacture and is not normally required again during the lifetime of an instrument.

13.1 Equipment Required For Checking or Calibrating the Universal Input

A suitable calibration signal source is required for each input type. To verify the accuracy of the instrument or carry out recalibration, the listed input sources are required, with better than $\pm 0.05\%$ of the reading accuracy:

1. DC linear inputs: 0 to 50mV, 0 to 10VDC and 0 to 20mADC.
2. Thermocouple inputs - complete with 0°C reference facility, appropriate thermocouple functions and compensating leads (or equivalent).
3. RTD inputs: decade resistance box with connections for three-wire input (or equivalent).

13.2 Calibration Check

1. Set the instrument to the required input type.
2. Power up the instrument and connect the correct input leads.
Leave powered up for at least five minutes for RTD and DC linear inputs, or at least 30 minutes for thermocouple inputs.
3. After the appropriate delay for stabilisation has elapsed, check the calibration by connecting the appropriate input source and checking a number of cardinal points.
4. Repeat the test for all required input types.

13.3 Recalibration Procedure

Recalibration is carried out in five phases as shown in the table below, each phase corresponds to an input range of the instrument.

CAUTION:

The 50mV phase MUST be calibrated before the thermocouple range.

Table 28. Calibration phases



iP_1	50 mV
iP_2	10 V
iP_3	20 mA
iP_4	RTD input (200 ohm)
iP_5	Thermocouple (K type source at 0°C required)

To start calibration, apply the required calibration input from the source type list above, using the correct connections,

1. Whilst the instrument is powering up, press  and  together until **iP_1** is displayed.

Note:

If a phase has not been previously calibrated the display will flash.

2. Press  to initiate calibration.
3. During calibration the display changes to **----** for a few seconds.
4. If the input is misconnected or an incorrect signal is applied the calibration will be aborted and the display will shown **FR L**. The previous calibration value will be retained.
5. If the calibration has succeeded, the pass display is shown **iP_1** (non-flashing).
6. Press  to step onto the next phase.
7. Repeat this process for each input type until all the phases are calibrated.
8. Switch off the instrument to exit the Calibration Mode.

Note:

An automatic exit is made from Calibration Mode if there is no button activity for five minutes.

14 Appendix 1 - Glossary

Active Setpoint: - Refer to *Setpoint Select*

Actual Setpoint: - Refer to *Setpoint Ramp Rate*

Alarm Hysteresis: An adjustable band on the “safe” side of an alarm point, through which the process variable must pass before the alarm will change state, as shown in the diagram below. E.g. a high alarm’s hysteresis band is below the high alarm value, and a low alarm’s hysteresis is above the low alarm value.

Also refer to *Alarm Operation*.

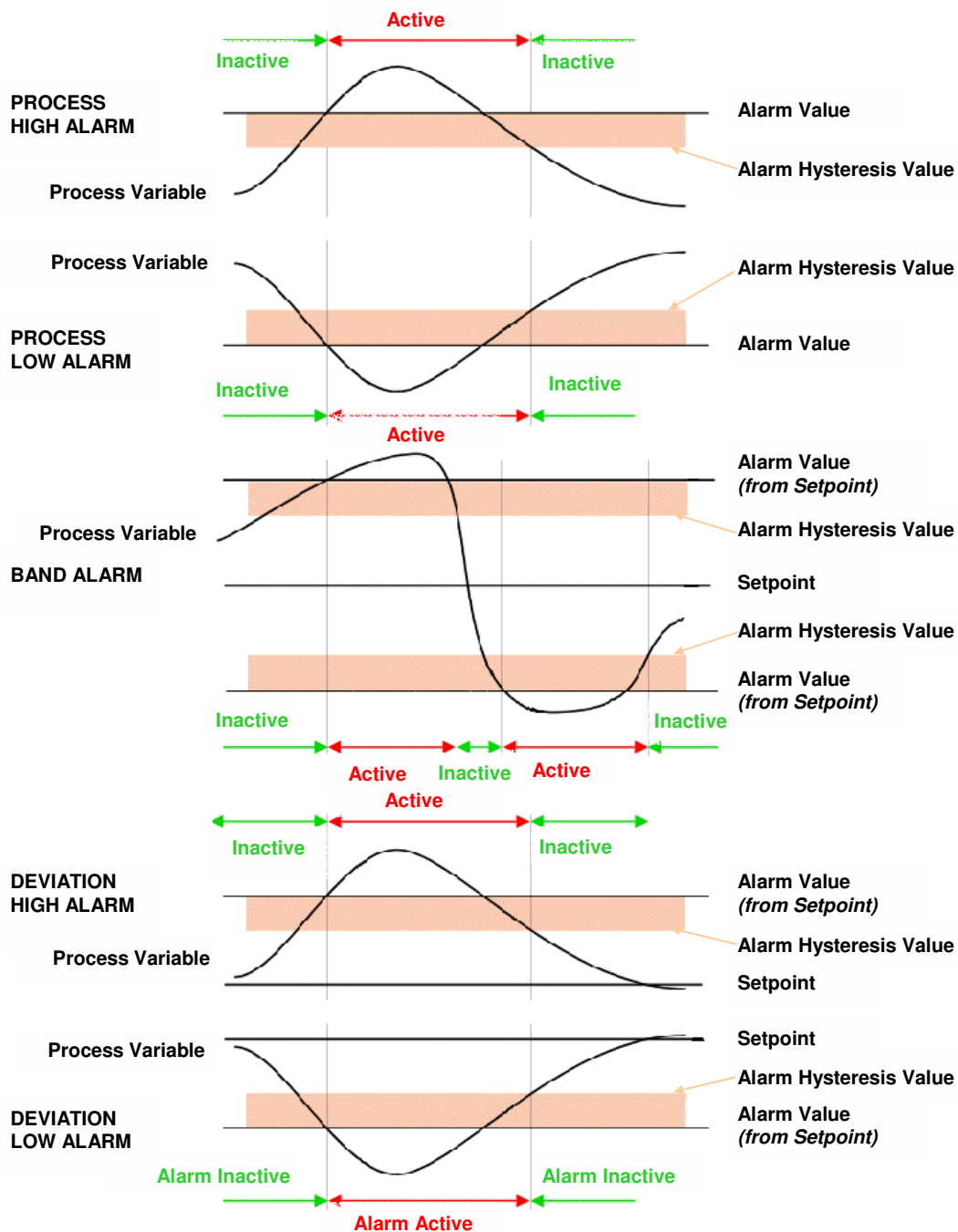

Figure 41. Alarm Hysteresis Operation

Alarm Operation: The operation of each alarm type is shown below, together with the switching action of an output relay (if this has been configured).
 Also refer to *Alarm Hysteresis, Alarm Inhibit, Band Alarm, Deviation Alarm, Logical Alarm Combinations, Loop Alarm, Process High Alarm and Process Low Alarm.*

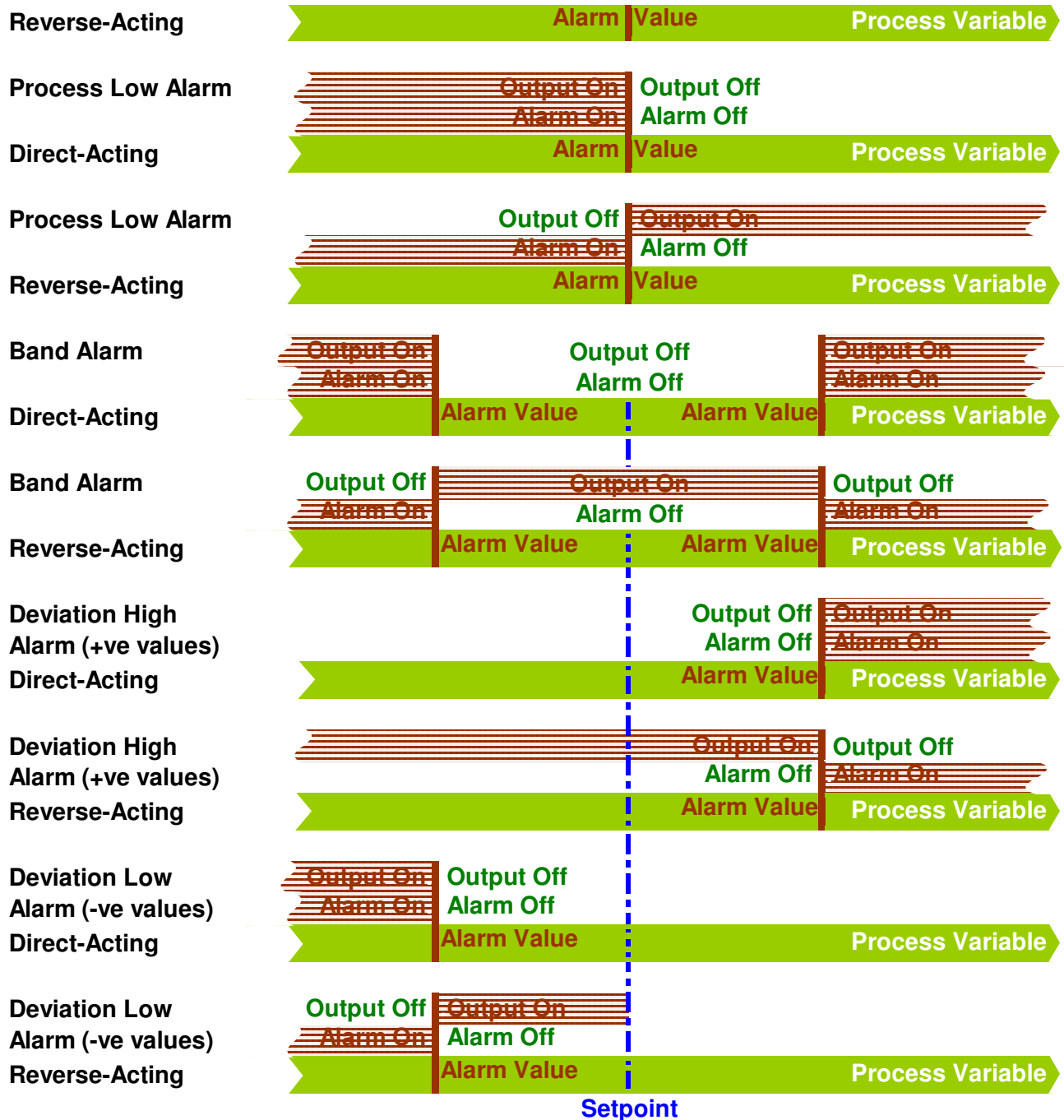

Figure 42. Alarm Operation

Alarm Inhibit: This inhibits an alarm at power-up or when the controller Setpoint is switched, until that alarm goes inactive. The alarm operates normally from that point onwards.

Also refer to Alarm Operation.

Automatic Reset (Integral): This is a controller tuning parameter. It is used to automatically bias the proportional output(s) to compensate for process load variations. It is adjustable in the range 1 seconds to 99 minutes 59 seconds per repeat and OFF (value greater than 99 minutes 59 seconds - display shows **OFF**). Decreasing the time increases the Integral action. This parameter is not available if the primary output is set to On-Off. The default value is five minutes and zero seconds (**5.00**) and the display code is **ARSt**.

Also refer to Primary Proportional Band, Secondary Proportional Band, Rate, PID, and Tuning.

Auto Pre-Tune: This is a controller parameter, it determines whether or not the Auto Pre-Tune mode is activated on power up (**d,SA** = disabled, **EnAb** = enabled). Auto Pre-Tune is useful when the process to be controlled varies significantly each time it is run. Auto Pre-Tune ensures that tuning occurs at the start of the process. Self-Tune may also be engaged to fine tune the controller. Default setting is disabled, display code is **APt**.

Also refer to Pre-Tune, Self-Tune and Tuning.

Band Alarm 1 Value: This is a controller parameter, it is applicable only if Alarm 1 is selected to be a Band Alarm, defines a band of process variable values, centred on the current actual setpoint value. If the process variable value is outside this band, the alarm will be active. This parameter may be adjusted from 1 to full span from the setpoint.

The default value is 5, the display code is **bAL 1**.

Also refer to Alarm Operation, Band Alarm 2 Value and Input Span.

Band Alarm 2 Value: This is a controller parameter, it is similar to the Band Alarm 1 Value. It is applicable only if Alarm 2 is selected to be a Band Alarm.

The default value is 5, the display code is **bAL2**.

Also refer to Alarm Operation, Band Alarm 1 Value and Input Span.

Bias (Manual Reset): This is a controller parameter, it is expressed as a percentage of output power and is adjustable in the range 0% to 100% (for Primary Output alone) or -100% to +100% (for both Primary and Secondary Outputs). This parameter is not applicable if the Primary output is set to ON/OFF control mode. If the process is below setpoint use a positive Bias value to remove the error, if the process variable is above the setpoint use a negative Bias value. Lower Bias values will also help to reduce overshoot at process start up.

The default value is 25%, the display code is **B,AS**.

Also refer to ON/OFF Control and PID.

Bumpless Transfer: The term “Bumpless Transfer” refers to the method used prevent sudden changes to the output power level when switching between Automatic and Manual control modes. During a transition from Automatic to Manual, the initial Manual Power value will be set to equal the previous automatic mode value. The operator can then adjust the value as required. During a transition from Manual to Automatic, the initial Automatic Power value will be set to equal the previous manual mode value. The correct power level will gradually applied by the control algorithm.

Also refer to Manual Mode.

Communications Write Enable: This parameter enables/disables the changing of parameter values via the RS485 communications link, if the communications option is installed. Settings are read only and read/write.

The default setting is **r-w** (read/write), the display code is **CoEn**.

CPU: This stands for Central Processing Unit and refers to the onboard microprocessor that controls all of the measuring, alarm and control functions of the instrument.

Current Proportioning Control: Current proportioning control can be implemented on units configured with linear current or voltage output(s). It provides a 4 to 20mA, 0-20mA, 0 to 5V, 0 to 10V or 2 - 10V DC PID output. On-Off control should not be used with Current proportioning control.

Also refer to On-Off Control, PID, Primary Proportional Band, Rate, Secondary Proportional Band and Time Proportional Control.

Cycle Time: This is a controller parameter. For time proportioning outputs, it is used to define time period over which the average on vs. off time is equal to the required PID output level. **Ct1**, **Ct2** and **Ct3** are available when option slots 1, 2 or 3 are defined as time proportioning output types. The permitted range of value is 0.5, 1, 2, 4, 8, 16, 32, 64, 128, 256 or 512 seconds. Shorter cycle times will give better control, but at the expense of reduce life when used with an electromechanical control device (e.g. relays or solenoid valves). The default value is 32, and the display codes are **Ct1**, **Ct2** and **Ct3**.

Also refer to PID and Time Proportioning.

Deadband: - Refer to *Overlap/Deadband*.

Derivative: - Refer to *Rate*.

Deviation Alarm 1 Value: This is a controller parameter. It is applicable only if Alarm 1 is selected to be Deviation Alarm. A positive value (Deviation High) sets the alarm point above the current actual setpoint, a negative value (Deviation Low) sets it below. If the process variable deviates from the setpoint by a margin greater than this value, alarm 1 becomes active. The default value is 5, the display code is **dAL1**.

Also refer to Alarm Operation and Deviation Alarm 2 Value.

Deviation Alarm 2 Value: This controller parameter is applicable only if Alarm 2 is selected as a Deviation Alarm. It is similar to Deviation Alarm 1 Value.

The default value is 5, the display code is **dAL2**.

Also refer to Alarm Operation and Deviation Alarm 1 Value.

Differential (On-Off Hysteresis): This is a controller parameter, it is a switching differential used when one or both control outputs have been set to On-Off. This parameter is adjustable within the range 0.1% to 10.0% of input span; the default value is 0.5%. The differential band is centred about the setpoint.

Relay chatter can be eliminated by proper adjustment of this parameter. Too large a value for this parameter will increase amplitude of oscillation in this process variable.

The display code is **dIFP** for primary only differential, **dIFS** for secondary only differential & **dIFF** for primary and secondary differential.

Also refer to Input Span and On-Off Control.

Direct/Reverse Operation of Control Outputs: Direct operation is typically used with cooling applications; On-Off direct outputs will turn on when the process variable exceeds setpoint. Proportional direct outputs will increase the percentage of output as the process value increases within the proportional band. Reverse operation is typically used with heating applications; On-Off reverse outputs will turn off when the process variable exceeds setpoint. Proportional reverse outputs will decrease the percentage of output as the process value increases within the proportional band. The Secondary Output will be direct whenever the Primary Output is selected as reverse. The Secondary Output will be reverse whenever the Primary Output is selected as direct.

Also refer to On-Off Control, PID, Primary Proportional Band and Secondary Proportional Band

Display Strategy: This controller parameter; allows the user to alter the parameters displayed in normal operator mode. These can be PV + SP, PV + adjustable SP, PV + Ramping SP, PV only or SP only. Display strategy 6 will allow read only access to the setpoint values in Operator Mode, Setup Mode must then be entered to change the setpoint. *Also refer to Process Variable, Setpoint and Setpoint Ramping.*

Input Filter Time Constant: This parameter is used to filter out extraneous impulses on the process variable. The filtered PV is used for all PV-dependent functions (display control, alarm etc). The time constant is adjustable from 0.0 seconds (off) to 100.0 seconds in 0.5 second increments. The default value is 2.0 seconds, the display code is **Filt**.

Also refer to Process Variable

Input Range: This is the overall process variable input range and type as selected by the **InPt** parameter in Configuration Mode.

Also refer to Input Span.

Input Span: This is the allowable measuring limits, as defined by the Scale Range Lower and Scale Range Upper Limits. The trimmed span value is also used as the basis for calculations that relate to the span of the instrument (E.g. controller proportional bands) *Also refer to Input Range, Scale Range Lower Limit and Scale Range Upper Limit.*

Integral: - Refer to *Automatic Reset*.

LED: Light Emitting Diode. LED's are used as indicator lights (e.g. for the alarm indication). The upper and lower 7-segment displays are also LED's.

Lock Codes: These parameters define the four-digit codes required to enter Configuration (20), Set-Up (10), and Auto Tuning (0) modes. The default values are shown in brackets, the display codes are **cLoc**, **SLoc** and **tLoc**.

Logical Combination of Alarms: Two alarms may be combined logically to create an AND/OR situation. They may be configured for Reverse-acting or Direct-acting. Any suitable output may be assigned as a Logical Alarm Output.

Also refer to Alarm Operation

Table 29. Logical Alarm Outputs

Logical OR: Alarm 1 OR Alarm 2											
Direct Acting						Reverse-Acting					
ALARM 1	OFF	ALARM 2	OFF	OUTPUT	OFF	ALARM 1	OFF	ALARM 2	OFF	OUTPUT	ON
	ON		OFF		ON		OFF		OFF		
	OFF		ON		ON		ON		OFF		
	ON		ON		ON		ON		OFF		

Logical AND: Alarm 1 AND Alarm 2											
Direct Acting						Reverse-Acting					
ALARM 1	OFF	ALARM 2	OFF	OUTPUT	OFF	ALARM 1	OFF	ALARM 2	OFF	OUTPUT	ON
	ON		OFF		OFF		ON		ON		
	OFF		ON		OFF		ON		ON		
	ON		ON		ON		ON		OFF		

Loop Alarm Enable: This controller parameter is the means by which the user can enable or disable the loop alarm. The loop alarm is a special alarm, which detects faults in the control feedback loop, by continuously monitoring process variable response to the control output(s). The loop alarm can be tied to any suitable output. When enabled, the loop alarm repeatedly checks if the control output(s) are at the maximum or minimum limit. If an output is at the limit, an internal timer is started: thereafter, if the high output has not caused the process variable to be corrected by a predetermined amount 'V' after time 'T' has elapsed, the loop alarm becomes active. Subsequently, the loop alarm mode repeatedly checks the process variable and the control output(s). When the process variable starts to change value in the correct sense or when the output is no longer at the limit, the loop alarm is deactivated.

For PID control, the loop alarm time 'T' is always twice the value of the Automatic Reset parameter. For On-Off control, a user defined value for the Loop Alarm Time parameter is used.

The value of 'V' is dependent upon the input type. For Temperature inputs, V = 2°C or 3°F. For Linear inputs, V = 10 least significant display units

Control output limits are 0% for Single output (Primary only) controllers and -100% for Dual output (Primary and Secondary) controllers.

Correct operation of the loop alarm depends upon reasonably accurate PID tuning. The loop alarm is automatically disabled during manual control mode and during execution of the Pre-Tune mode. Upon exit from manual mode or after completion of the Pre-Tune routine, the loop alarm is automatically re-enabled.

Also refer to Loop Alarm Time, Manual Mode, On-Off Control, Pre-Tune, and Process Variable.

Loop Alarm Time: This is a controller parameter. When On-Off control is selected and loop alarm is enabled, this parameter determines the duration of the limit condition after which the loop alarm will be activated. It may be adjusted within the range of 1 second to 99 minutes 59 seconds. This parameter is omitted from the Set-up mode display sequence if On-Off control is not selected or loop alarm is disabled.

The default setting is 99:59 and the display code is **LALt**.
Also refer to Loop Alarm Enable.

mADC: This stands for milliamp DC. It is used in reference to the DC milliamp input ranges and the linear DC milliamp outputs. Typically these will be 0 to 20mA or 4 to 20mA.

Manual Mode Enable: This controller parameter determines whether operator selection/deselection of manual control is enabled. If the mode is enabled in Set-Up mode, pressing the AM key in operator mode will cause a controller to enter or leave manual control mode. In manual mode, the upper display shows the current process value, the lower display shows the output power in the form - **P_{xxx}** (where xxx is equal to the percentage output power). The power value may be adjusted using the UP or DOWN keys. The value can be varied between 0% to 100% for instruments using primary control only, and -100% to +100% for controllers using primary and secondary (e.g. heat & cool). This mode should be used with care because the power output level is set by the operator, therefore the PID algorithm is no longer in control of the process. The operator **MUST** maintain the process as the desired level manually. Manual power is not limited by the Primary Power Output Limit.

The default setting is Disabled and the display code is **PoEn**.
Also refer to Bumpless Transfer, PID, and Primary Output Power Limit

Offset: This parameter is used to modify the measured process variable value and is adjustable in the range \pm input span. Use this parameter only when necessary to compensate for an error in the process variable reading. Positive values are added to the process variable reading, negative values are subtracted. This parameter **MUST** be used with care, because adjustment of this parameter is in effect, a calibration adjustment. Injudicious application of values to this parameter could lead to the displayed process variable value bearing no meaningful relationship to the actual process variable value. There is no front panel indication of when this parameter is in use.

The default value is 0 and the display value is **OFFS**.
Also refer to Input Span and Process Variable.

On-Off Control: This is a controller parameter. When operating in On-Off control, the output(s) will turn on or off as the process variable crosses the setpoint in a manner similar to a central heating thermostat. Some oscillation of the process variable is inevitable when using On-Off control.

On-Off control can be implemented only with Time Proportioning Control (Relay, Triac or SSR driver output), by setting the corresponding proportional band(s) to zero. On-Off operation can be assigned to the Primary output alone (secondary output not present), Primary and Secondary outputs or Secondary output only (with the primary Output set for time proportional or current proportional control).

Also refer to Differential, PID, Process Variable, Primary Proportional Band, Secondary Proportional Band, Setpoint and Time Proportioning Control.

On-Off Differential (Hysteresis): - Refer to *Differential*.

Overlap/Deadband: This parameter defines the portion of the primary and secondary proportional bands ($Pb_P + Pb_S$) over which both outputs are active (Overlap), or neither is active (Deadband). It is adjustable in the range -20% to +20% of the two proportional bands added together. Positive values = Overlap, negative values = Deadband. This parameter is not applicable if the primary output is set for On-Off control or there is no Secondary Output. The display code is **OL**, the default value is 0%. If the Secondary Output is set for On-Off, this parameter has the effect of moving the Differential band of the Secondary Output to create the overlap or deadband. When Overlap/Deadband = 0, the “OFF” edge of the Secondary Output Differential band coincides with the point at which the Primary Output = 0%.). Also refer to *Differential*, *On-Off Control*, *Primary Proportional Band* and *Secondary Proportional Band*.

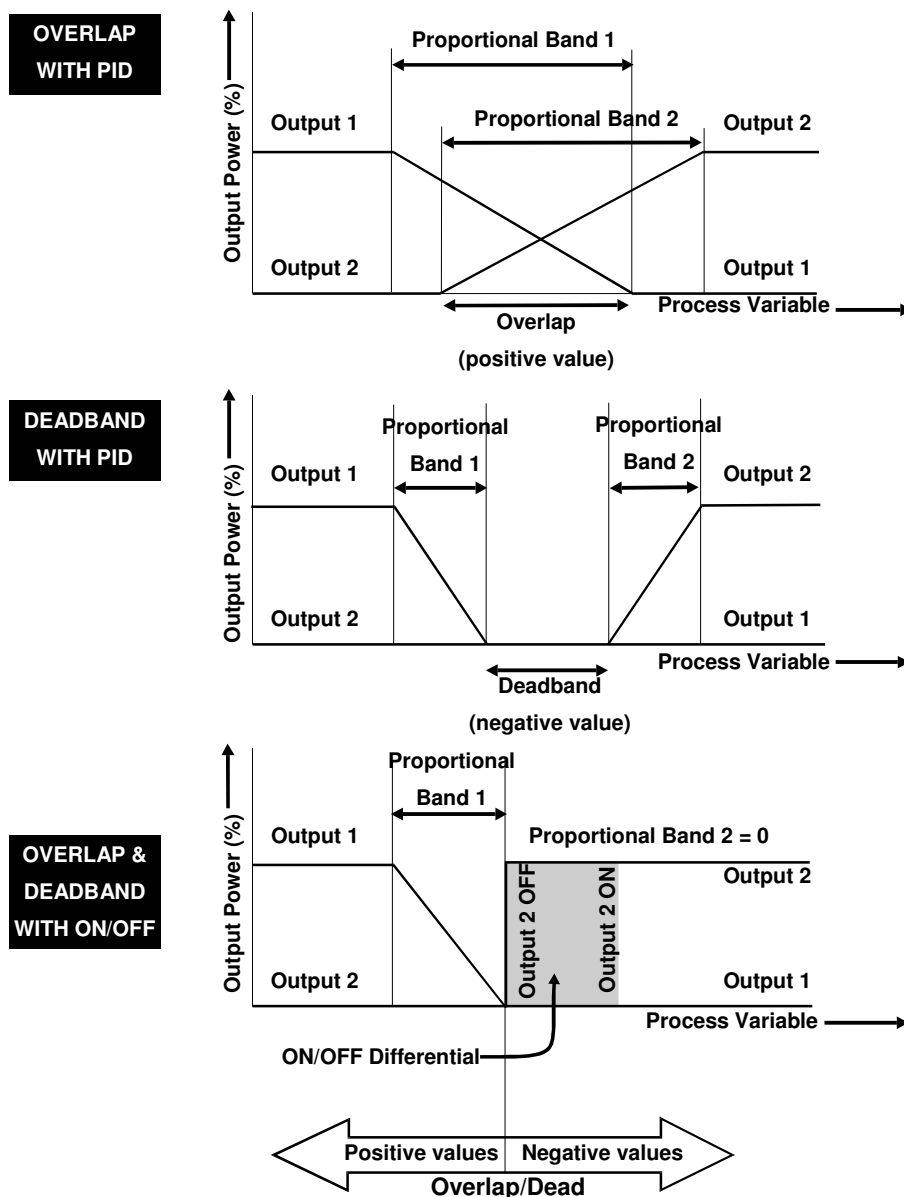

Figure 43. Overlap and Deadband

PID: This stands for Proportional Integral and Derivative. A control method that accurately maintains the desired level in process, e.g. controlling a temperature. It avoids the oscillation characteristic of On-Off control by continuously adjusting the power output level to keep the process variable stable at the desired target setpoint.

Also refer to Automatic Reset, On-Off Control, Primary Proportional Band, Process Variable, Rate, Secondary Proportional Band, Setpoint and Tuning

PLC: This stands for Programmable Logic Controller. A microprocessor based device used in machine control. It is particularly suited to sequential control applications, and uses “Ladder Logic” programming techniques. Some PLC’s are capable of basic PID control, but tend to be expensive and often give inferior levels of control.

Also refer to PID.

Pre-Tune: This is a controller parameter. The Pre-Tune facility artificially disturbs the start-up pattern so that a first approximation of the PID values can be made prior to the setpoint being reached. During Pre-Tune, the controller demands full power until the process value has moved approximately halfway to the setpoint. At that point, power is removed, thereby introducing an oscillation. Once the oscillation peak has passed, the Pre-Tune algorithm calculates an approximation of the optimum PID tuning terms proportional band(s), automatic reset and rate. The process is shown in the diagram below.

When Pre-Tune is completed, the PID control output power is applied using the calculated values. Pre-Tune limits the possibility of setpoint overshoot when the controller is new or the application has been changed. As a single-shot operation, it will automatically disengage once complete, but can be configured to run at every power up using the Auto Pre-Tune function. Pre-Tune will not engage if either primary or secondary outputs on a controller are set for On-Off control, during setpoint ramping or if the process variable is less than 5% of the input span from the setpoint.

Also refer to Auto Pre-Tune, Automatic Reset, On-Off Control, Input Span, PID, Primary Proportional Band, Process Variable, Rate, Secondary Proportional Band, Self-Tune, Setpoint, Setpoint Ramping and Tuning.

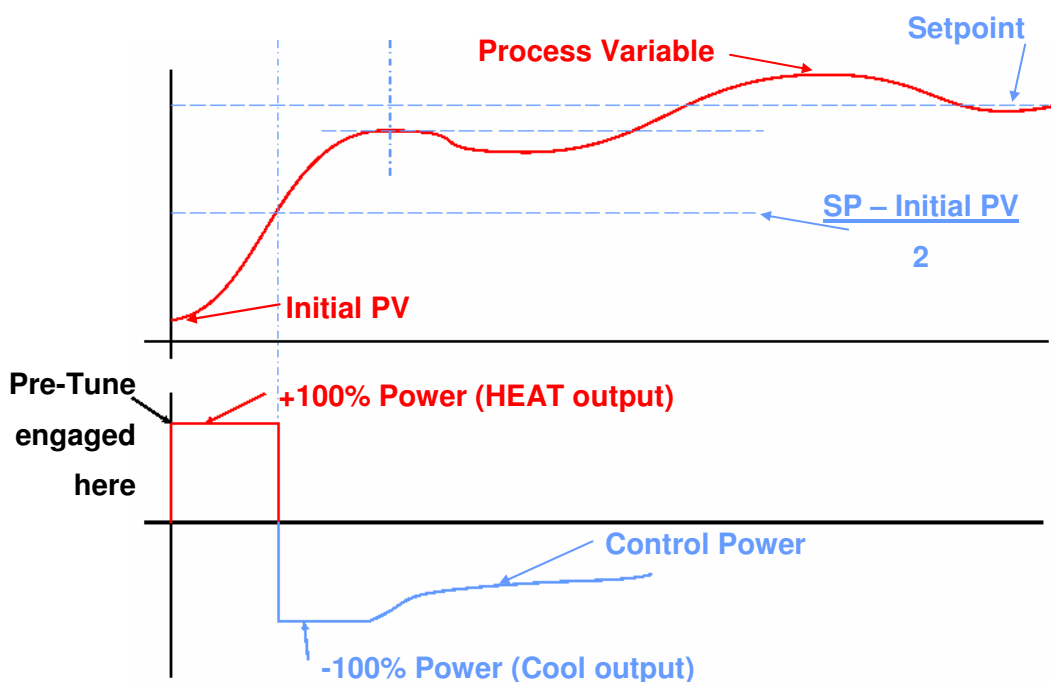

Figure 44. Pre-Tune Operation

Primary Output Power Limit: This is a controller parameter; it is used to limit the power level of the Primary Output and may be used to protect the process being controlled. It may be adjusted between 0% and 100%. This parameter is not applicable if the primary output is set for On-Off control. The display code is **OPh 1**.

Also refer to On-Off Control.

Primary Proportional Band: This is a controller tuning parameter. It is the portion of the input span over which the Primary Output power level is proportional to the process variable value. It may be adjusted in the range 0.0% (ON/OFF) to 999.9%. The default value is 5.0% and the display value is **Pb_P**.

Also refer to On-Off Control, Input Span, Overlap/Deadband, PID, Secondary Proportional Band, and Tuning.

Process High Alarm 1 Value: This parameter, applicable only when Alarm 1 is selected to be a Process High alarm, defines the process variable value above which Alarm 1 will be active. Its value may be adjusted between Scale Range Upper Limit and Scale Range Lower Limit. Its default value is Scale Range Upper Limit and the display code is **PHA 1**.

Also refer to Alarm Operation, Process High Alarm 2 Value, Process Variable, Scale Range Lower Limit and Scale Range Upper Limit.

Process High Alarm 2 Value: This parameter, applicable only when Alarm 2 is selected to be a Process High alarm. It is similar to the Process High Alarm 1 Value. Its default value is Scale Range Upper Limit and the display code is **PHA2**.

Also refer to Alarm Operation, Process High Alarm 1 Value, Process Variable, Scale Range Lower Limit and Scale Range Upper Limit.

Process Low Alarm 1 Value: This parameter, applicable only when Alarm 1 is selected to be a Process low alarm, defines the process variable value below which Alarm 1 will be active. Its value may be adjusted between Scale Range Upper Limit and Scale Range Lower Limit. Its default value is Scale Range Lower Limit and the display code is **PLA 1**.

Also refer to Alarm Operation, Process Low Alarm 2 Value, Process Variable, Scale Range Lower Limit and Scale Range Upper Limit.

Process Low Alarm 2 Value: This parameter, applicable only when Alarm 2 is selected to be a Process low alarm. It is similar to the Process Low Alarm 1 Value. Its default value is Scale Range Lower Limit and the display code is **PLA2**.

Also refer to Alarm Operation, Process Low Alarm 1 Value, Process Variable, Scale Range Lower Limit and Scale Range Upper Limit.

Process Variable: The Process Variable (PV) is the variable to be measured by the primary input of the instrument. The PV can be any parameter that can be converted into a electronic signal suitable for the input. Common types are Thermocouple or PT100 temperature probes, or pressure, level, flow etc from transducers which convert these parameters into linear DC signals (e.g. 4 to 20mA). Linear signals can be scaled into engineering units using the Scale Range Lower Limit and Scale Range Upper Limit parameters.

Also refer to Input Span, Scale Range Lower Limit and Scale Range Upper Limit.

Process Variable Offset: - Refer to *Offset*.

Rate (Derivative): This is a controller tuning parameter. It is adjustable in the range 0 seconds (OFF) to 99 minutes 59 seconds and specifies how the control action responds to the rate of change in the process variable. This parameter should not be used in modulating value applications as it can cause premature wear due to constant small adjustments to the valve position. The Rate parameter is not available if primary control output is set to On-Off. The default value is 1.15 and the display code is **rRtE**.
Also refer to On-Off Control, PID, Process Variable and Tuning.

Remote Setpoint: This is a controller setpoint whose value can be externally adjusted using a linear DC Voltage or mA input signal, or in some cases potentiometer or mV inputs. The Remote Setpoint value is constrained by the Setpoint Upper Limit and Setpoint Lower Limit settings. The display code is **rSP**.
Also refer to Remote Setpoint Input, Remote Setpoint Lower Limit, Remote Setpoint Upper Limit, Setpoint and Setpoint Select.

Remote Setpoint Input: This is a controller parameter that defines the type of linear input signal, mADC, mVDC, VDC or potentiometer that will be used to adjust the Remote Setpoint value. mVDC and potentiometer are available with Full RSP module only.
Also refer to Remote Setpoint and Setpoint.

Remote Setpoint Lower Limit: This controller parameter defines the value of the Remote Setpoint when the RSP input signal is at its minimum value (eg for a 4 to 20mA RSP, the value when 4mA is applied). It may be adjusted within the range -1999 to 9999; (decimal position same as for process variable input). However, the RSP value is always constrained within the Setpoint Upper Limit and Setpoint Lower Limits.
The default value is PV input range minimum and the display code is **rSPL**.
Also refer to Remote Setpoint, Remote Setpoint Input, Remote Setpoint Upper Limit, Remote Setpoint Offset, Setpoint and Setpoint Upper Limit and Setpoint Lower Limit.

Remote Setpoint Upper Limit: This controller parameter defines the value of the Remote Setpoint when the RSP input signal is at its maximum value (eg for a 4 to 20mA RSP, the value when 20mA is applied). It may be adjusted within the range -1999 to 9999; (decimal position same as for process variable input). However, the RSP value is always constrained within the Setpoint Upper Limit and Setpoint Lower Limits.
The default value is PV input range maximum and the display code is **rSPu**.
Also refer to Remote Setpoint, Remote Setpoint Input, Remote Setpoint Lower Limit, Remote Setpoint Offset, Setpoint and Setpoint Upper Limit and Setpoint Lower Limit.

Remote Setpoint Offset: This parameter is used to modify the Remote Setpoint input value. Positive values are added to the RSP reading, negative values are subtracted. It is adjustable in the range -1999 to 9999, but is constrained within the Scale Range Upper Limit and Scale Range Lower Limit.
The default value is 0 and the display value is **rSPo**.
Also refer to Remote Setpoint, Scale Range Upper Limit and Scale Range Lower Limit.

Retransmit Output: This can be used to transmit a linear DC voltage or mA signal proportional to the Process Variable or Setpoint to an external device, such as a Data Recorder or PLC. The output can be scaled to transmit any portion of the input or setpoint span.
Also refer to Input Span, Process Variable and Setpoint.

Retransmit Output 1 Scale Maximum: This parameter can be used with a linear output module in slot 1 to retransmit an analogue signal proportional to either the process variable or controller setpoint values to external devices. The retransmit Scale Maximum defines the value of the process variable, or setpoint, at which the output will be at its maximum value. E.g. for a 0 to 5V output, the value corresponds to 5V. It may be adjusted within the range -1999 to 9999; the decimal position is always the same as that for the process variable input. If this parameter is set to a value less than that for Retransmit Output 1 Scale Minimum, the relationship between the process variable/setpoint value and the retransmission output is reversed.

The default value is Scale Range Upper Limit and the display code is **roIH**.

Also refer to Process Variable, Retransmit Output, Retransmit Output 1 Scale Minimum, Scale Range Upper Limit and Setpoint.

Retransmit Output 1 Scale Minimum: This parameter can be used with a linear output module in slot 1 to retransmit an analogue signal proportional to either the process variable or controller setpoint values to external devices. The retransmit Scale Minimum defines the value of the process variable, or setpoint, at which the output will be at its minimum value. E.g. for a 0 to 5V output, the value corresponds to 0V. It may be adjusted within the range -1999 to 9999; the decimal position is always the same as that for the process variable input. If this parameter is set to a value greater than that for Retransmit Output Scale Maximum, the relationship between the process variable/setpoint value and the retransmission output is reversed.

The default value is Scale Range Lower Limit and the display code is **roIL**.

Also refer to Process Variable, Retransmit Output, Retransmit Output 1 Scale Maximum, Scale Range Lower Limit and Setpoint.

Retransmit Output 2 Scale Maximum: This parameter defines the value of the process variable, or setpoint, at which Retransmit Output 2 will be at its maximum value. It is similar to Retransmit Output 1 Scale Maximum.

The default value is Scale Range Upper Limit and the display code is **ro2H**.

Also refer to Process Variable, Retransmit Output, Retransmit Output 2 Scale Minimum, Scale Range Upper Limit and Setpoint.

Retransmit Output 2 Scale Minimum: This parameter defines the value of the process variable, or setpoint, at which Retransmit Output 2 will be at its minimum value. It is similar to Retransmit Output 1 Scale Minimum.

The default value is Scale Range Lower Limit and the display code is **ro2L**.

Also refer to Process Variable, Retransmit Output, Retransmit Output 2 Scale Maximum, Scale Range Lower Limit and Setpoint.

Retransmit Output 3 Scale Maximum: This parameter defines the value of the process variable, or setpoint, at which Retransmit Output 3 will be at its maximum value. It is similar to Retransmit Output 1 Scale Maximum.

The default value is Scale Range Upper Limit and the display code is **ro3H**.

Also refer to Process Variable, Retransmit Output, Retransmit Output 3 Scale Minimum, Scale Range Upper Limit and Setpoint.

Retransmit Output 3 Scale Minimum: This parameter defines the value of the process variable, or setpoint, at which Retransmit Output 3 will be at its minimum value. It is similar to Retransmit Output 1 Scale Minimum.

The default value is Scale Range Lower Limit and the display code is **ro3L**.

Also refer to Process Variable, Retransmit Output, Retransmit Output 3 Scale Maximum, Scale Range Lower Limit and Setpoint.

Reset: - Refer to *Automatic Reset*.

Scale Range Upper Limit: For a linear input, this parameter can be used to display the process variable in engineering units. It defines the displayed value when the process variable input is at its maximum value. It is adjustable from -1999 to 9999 and can be set to a value less than (but not within 100 units of) the Scale Range Lower Limit, in which case the sense of the input is reversed.

For thermocouple and RTD inputs, this parameter is used to reduce the effective range of the input. All span related functions work from the trimmed input span. The parameter can be adjusted within the limits of the range selected by Configuration Mode parameter **inPt**. It is adjustable to within 100 degrees of the Scale Range Lower Limit.

The default value is 1000 for linear input or range maximum for temperature inputs. The display code is **rUL**.

Also refer to Input Span, Process Variable and Scale Range Lower Limit.

Scale Range Lower Limit: For a linear input, this parameter can be used to display the process variable in engineering units. It defines the displayed value when the process variable input is at its minimum value. It is adjustable from -1999 to 9999 and can be set to a value more than (but not within 100 units of) the Scale Range Upper Limit, in which case the sense of the input is reversed.

For thermocouple and RTD inputs, this parameter is used to reduce the effective range of the input. All span related functions, work from the trimmed span. The parameter can be adjusted within the limits of the range selected by Configuration Mode parameter **inPt**. It is adjustable to within 100 degrees of the Scale Range Upper Limit. The default value is 0 for linear inputs, or range minimum for temperature inputs. The display code is **rUL**.

Also refer to Input Span, Process Variable and Scale Range Upper Limit.

Secondary Proportional Band: This is a controller tuning parameter. It is the portion of the input span over which the Secondary Output power level is proportional to the process variable value. It may be adjusted in the range 0.0% (ON/OFF) to 999.9%. The default value is 5.0% and the display value is **Pb_5**.

Also refer to On-Off Control, Input Span, Overlap/Deadband, PID, Primary Proportional Band and Tuning.

Self-Tune: Self-tune is used to optimise tuning while a controller is operating; it uses a pattern recognition algorithm, which monitors the process error (deviation signal). The diagram below shows a typical temperature application involving a process start up, setpoint

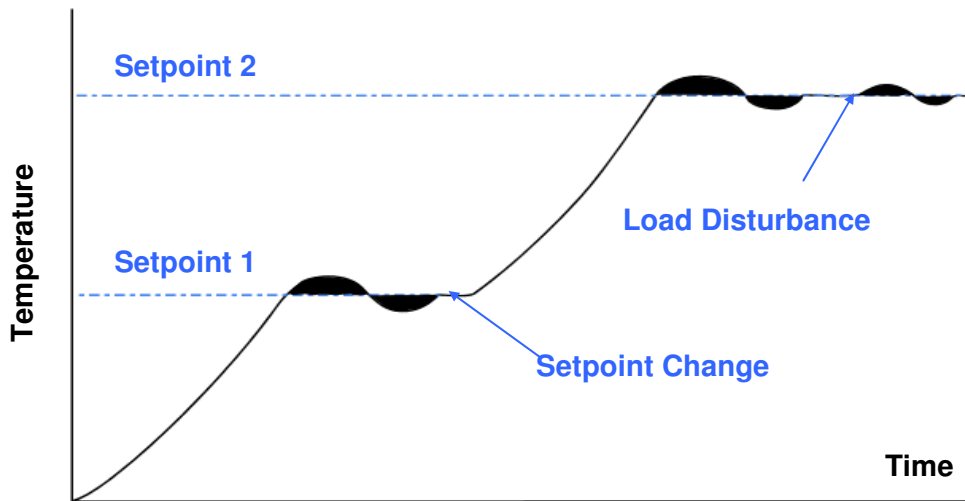

change and load disturbance.

Figure 45. Self-Tune Operation

The deviation signal is shown shaded and overshoots have been exaggerated for clarity. The Self-Tune algorithm observes one complete deviation oscillation before calculating a set of PID values. Successive deviation oscillation causes values to be recalculated so that the controller rapidly converges on optimal control. When the controller is switched off, the final PID terms remain stored in the controller's non-volatile memory, and are used as starting values at the next switch on. The stored values may not always be valid, if for instance the controller is brand new or the application has been changed. In these cases the user can utilise Pre-Tune to establish new initial values.

Use of continuous self-tune is not always appropriate for applications which are frequently subjected to artificial load disturbances, for example where an oven door is likely to be frequently left open for extended periods of time. Self-Tune cannot be engaged if a controller is set for On-Off Control.

Also refer to On-Off Control, Pre-Tune, PID, and Tuning.

Setpoint: This controller parameter is the target value at which the controller will attempt to maintain the process variable, by making adjustments to the power output level. Controllers can have either one or two setpoints. These can be one or two local internal setpoints (**SP** or **SP 1** and **SP 2**), or one local internal setpoint (**LSP**) and one externally adjusted remote (**rSP**) setpoint, if a Remote Setpoint module is fitted. The value of the setpoints can be adjusted between the Setpoint Upper Limit and Setpoint Lower Limits. The active setpoint is defined by the status of the Setpoint Select parameter or a digital input.

Also refer to Process Variable, Remote Setpoint, Scale Range Lower Limit, Setpoint Lower Limit, Setpoint Upper Limit and Setpoint Select

Setpoint Upper Limit: This is a controller parameter; it is the maximum limit for setpoint adjustment. It should be set to keep the setpoint below a value that might cause damage to the process. The range of adjustment is between Scale Range Upper Limit and Scale Range Lower Limit. The value cannot be moved below the current value of the setpoint.

The default value is Scale Range Upper Limit and the display code is **SPUL**.

Also refer to Scale Range Lower Limit, Scale Range Upper Limit, Setpoint and Setpoint Lower Limit.

Setpoint Lower Limit: This controller parameter is the minimum limit for setpoint adjustment. It should be set to keep the setpoint above a value that might cause damage to the process. The range of adjustment is between Scale Range Lower Limit and Scale Range Upper Limit. The value cannot be moved above the current value of the setpoint.

The default value is Scale Range Lower Limit and the display code is **SPLL**.

Also refer to Scale Range Lower Limit, Scale Range Upper Limit, Setpoint and Setpoint Upper Limit.

Setpoint Ramping Enable: This controller parameter enables and disables the viewing and adjustment of the Setpoint Ramp Rate in Operator Mode. This parameter does not disable the ramping SP feature; it merely removes it from Operator Mode. It can still be viewed and adjusted in Setup Mode. To turn off ramping, the ramp rate must be set to OFF (*blank*).

The default setting is Disabled and the display code is **SPr**.

Also refer to Process Variable, Setpoint and Setpoint Ramp Rate.

Setpoint Ramp Rate: This controller parameter is the rate at which the actual setpoint value will move towards its target value, when the setpoint value is adjusted or the active setpoint is changed. With ramping in use, the initial value of the actual setpoint at power up, or when switching back to automatic mode from manual control, will be equal to the current process variable value. The actual setpoint will rise/fall at the ramp rate set, until it reaches the target setpoint value. Setpoint ramping is used to protect the process from sudden changes in the setpoint which would result in a rapid rise in the process variable.

The default setting is OFF (*blank*) and the display code is **rP**.

Also refer to Manual Mode, Setpoint, Setpoint Ramp Enable and Setpoint Select.

Setpoint Select: This Operator Mode parameter is available if the remote setpoint feature is in use and setpoint select is enabled, Setpoint Select defines whether the local or the remote setpoint will be “active” (the setpoint used for the current target SP value). It can be set to **d i**, **LSP**, or **rSP**. If a digital input has been configured for local/remote setpoint selection, the default setting is **d i**. This means the status of the digital input will determine which setpoint is active. Otherwise the user can only choose **LSP**, or **rSP**. The active setpoint is indicated by prefixing its legend with the “**ˆ**” character. E.g. the local setpoint legend is **ˆLSP**,

when it is active and **LSP** when it is inactive.

If a digital input has been configured to select local/remote SP, setting Setpoint Select to **LSP**, or **rSP** will override the digital input and the active SP indication changes to **L**.

The display code is **SPS**.

Also refer to Remote Setpoint, Setpoint and Setpoint Select Enable.

Setpoint Select Enable: This is a controller Set-Up Mode parameter. If the remote setpoint feature is in use, this determines whether operator selection of setpoints is enabled or disabled. If enabled, the Setpoint Select parameter is available in operator mode. If Setpoint Select is disabled again, the active setpoint will remain at its current status.

The default setting is Disabled and the display code is **SSEn**.

Also refer to Remote Setpoint and Setpoint.

SSR: Solid State Relay. An external device manufactured using two silicone controlled rectifiers, which can be used to replace mechanical relays in most AC power applications. As a solid state device, an SSR does not suffer from contact degradation when switching electrical current. Much faster switching cycle times are also possible, leading to superior control. The instrument's SSR Driver output is a time proportioned 10VDC pulse which causes conduction of current to the load when the pulse is on.

Also refer to Cycle Time, Time Proportioning Control, and Triac.

Time Proportioning Control: Time proportioning control is accomplished by cycling the output on and off, during the prescribed cycle time, whenever the process variable is within the proportional band. The control algorithm determines the ratio of time (on vs. off) to achieve the level of output power required to correct any error between the process value and setpoint. E.g. for a 32 second cycle time, 25% power would result in the output turning on for 8 seconds, then off to 24 seconds. Time proportioning control can be implemented with Relay, Triac or SSR Driver outputs for either primary (Heat) or secondary (Cool) outputs depending on hardware configuration.

Also refer to Current Proportioning Control, Cycle Time, PID, Primary Proportional Band, Process Variable, Secondary Proportional Band, Setpoint, SSR and Triac.

Tuning: PID Controllers must be tuned to the process in order for them to attain the optimum level of control. Adjustment is made to the tuning terms either manually, or by utilising the controller's automatic tuning facilities. Tuning is not required if the controller is configured for On-Off Control.

Also refer to Automatic Reset, Auto Pre-Tune, On-Off control, PID, Pre-Tune, Primary Proportional Band, Rate, Self-Tune and Secondary Proportional Band.

Triac: A small internal solid state device, which can be used in place of a mechanical relay in applications switching low power AC, up to 1 amp. Like a relay, the output is time proportioned, but much faster switching cycle times are also possible, leading to superior control. As a solid-state device, a Triac does not suffer from contact degradation when switching electrical currents. A triac cannot be used to switch DC power.

Also refer to Cycle Time, SSR and Time Proportioning Control.

15 Appendix 2 - Specification

15.1 Universal Input

15.1.1 General Input Specifications

Input Sample Rate:	Four samples/second.	
Digital Input Filter time constant	0.0 (OFF), 0.5 to 100.0 seconds in 0.5 second increments.	
Input Resolution:	14 bits approximately. Always four times better than display resolution.	
Input Impedance:	10V DC:	47KΩ
	20mA DC:	5Ω
	Other ranges:	Greater than 10MΩ resistive
Isolation:	Isolated from all outputs (except SSR driver). If relay outputs are connected to a hazardous voltage source, and the universal input is connected to operator accessible circuits, supplementary insulation or input grounding is required.	
PV Offset:	Adjustable ±input span.	
PV Display:	Displays process variable up to 5% over and 5% under span.	

15.1.2 Thermocouple

Thermocouple Ranges Available

Sensor Type	Range Min in °C	Range Max in °C	Range Min in °F	Range Max in °F	Resolution
J (default)	-200	1200	-328	2192	1°
J	-128.8	537.7	-199.9	999.9	0.1°
T	-240	400	-400	752	1°
T	-128.8	400.0	-199.9	752.0	0.1°
K	-240	1373	-400	2503	1°
K	-128.8	537.7	-199.9	999.9	0.1°
L	0	762	32	1403	1°
L	0.0	537.7	32.0	999.9	0.1°
N	0	1399	32	2551	1°
B	100	1824	211	3315	1°
R	0	1759	32	3198	1°
S	0	1762	32	3204	1°
C	0	2320	32	4208	1°
PtRh20%: PtRh40%	0	1850	32	3362	1°

Note:

Defaults to °F for USA units. Defaults to °C for non-USA units.

The Configuration Mode parameters, Scale Range Upper Limit and Scale Range Lower Limit, can be used to restrict range.

Thermocouple Performance

Calibration:	Complies with BS4937, NBS125 and IEC584.
Measurement Accuracy:	±0.1% of full range span ±1LSD. NOTE: Reduced performance for B Thermocouple from 100 to 600°C. NOTE: PtRh 20% vs PtRh 40% Thermocouple accuracy is 0.25% and has reduced performance below 800°C.
Linearisation Accuracy:	Better than ±0.2°C any point, for 0.1° resolution ranges (±0.05°C typical). Better than ±0.5°C any point, for 1° resolution ranges.
Cold Junction Compensation:	Better than ±0.7°C under reference conditions. Better than ±1°C under operating conditions.
Temperature Stability:	0.01% of span/°C change in ambient temperature.
Supply Voltage Influence:	Negligible.
Relative Humidity Influence:	Negligible.
Sensor Resistance Influence:	Thermocouple 100Ω: <0.1% of span error. Thermocouple 1000Ω: <0.5% of span error.
Sensor Break Protection:	Break detect approx two seconds. Control outputs turn OFF (0% power); Alarms operate as if the process variable is over-range.

15.1.3 Resistance Temperature Detector (RTD)
RTD Ranges Available

Range Min in °C	Range Max in °C	Range Min in °F	Range Max in °F	Resolution
-128.8	537.7	-199.9	999.9	0.1°
-199	800	-328	1472	1° (default)

Note:

Scale Range Upper Limit and Scale Range Lower Limit Configuration Mode parameters can be used to restrict range.

RTD Performance

Type:	Three-wire Pt100.
Calibration:	Complies with BS1904 and DIN43760 ($0.00385\Omega/\Omega/^{\circ}\text{C}$).
Measurement Accuracy:	$\pm 0.1\%$ of span $\pm 1\text{LSD}$.
Linearisation Accuracy:	Better than $\pm 0.2^{\circ}\text{C}$ any point, any 0.1°C range ($\pm 0.05^{\circ}\text{C}$ typical). Better than $\pm 0.5^{\circ}\text{C}$ any point, any 1°C range.
Temperature Stability:	0.01% of span/ $^{\circ}\text{C}$ change in ambient temperature.
Supply Voltage Influence:	Negligible.
Relative Humidity Influence:	Negligible.
Sensor Resistance Influence:	Pt100 50 Ω /lead: <0.5% of span error.
Lead Compensation:	Automatic scheme.
RTD Sensor Current:	150 μA (approximately).
Sensor Break Protection:	Break detected within two seconds. Control outputs set to OFF (0% power). Alarms operate as if the process variable has gone over-range.

15.1.4DC Linear
DC Linear Ranges Available

0 to 20mA	0 to 50mV	0 to 5V
4 to 20mA (default)	10 to 50mV	1 to 5V
		0 to 10V
		2 to 10V

DC Linear Performance

Scale Range Upper Limit:	-1999 to 9999. Decimal point as required.
Scale Range Lower Limit:	-1999 to 9999. Decimal point as for Scale Range Upper Limit.
Minimum Span:	1 display LSD.
Measurement Accuracy:	$\pm 0.1\%$ of span $\pm 1\text{LSD}$.
Temperature stability:	0.01% of span/ $^{\circ}\text{C}$ change in ambient temperature.
Supply Voltage Influence:	Negligible.
Relative Humidity Influence:	Negligible.
Input Protection:	For DC current ranges up to 1A for normal polarity connection.
Sensor Break Protection:	Applicable for 4 to 20mA, 1 to 5V and 2 to 10V ranges only. Break detected within two seconds. Control outputs set to OFF (0% power); Alarms operate as if process variable is under-range.

15.2 Remote Setpoint Input

Input Sampling rate:	4 per second
Input Resolution:	13 bits minimum
Input types:	4 to 20mA, 0 to 20mA, 0 to 10V, 2 to 10V, 0 to 5V, 1 to 5V. The Full RSP in Option Slot B also supports 0 to 100mv and Potentiometer (2KΩ or higher).
Measurement Accuracy (reference conditions):	±0.25% of input span ±1 LSD
Input resistance:	Voltage ranges: 47KΩ nominal Current ranges: 5Ω
Input protection:	Voltage input: will withstand up to 5x input voltage overload without damage or degradation of performance in either polarity. Current input: will withstand 5x input current overload in reverse direction and up to 1A in the normal direction.
Isolation:	Slot A has basic isolation from other inputs and outputs. Slot B has reinforced isolation from other inputs and outputs.
Sensor Break Detection:	For 4 to 20mA, 2 to 10V and 1 to 5V ranges only.

15.3 Digital Inputs

Type:	Voltage-free or TTL-compatible
Voltage-Free Operation:	Connection to contacts of external switch or relay: Open = SP1, Auto mode or Local setpoint selected (minimum contact resistance = 5KΩ), Closed = SP2, Manual mode or Remote Setpoint selected (maximum contact resistance = 50Ω).
TTL levels:	2.0V to 24. = SP1(or Auto) selected -0.6V to 0.8V. = SP2(or Man) selected
Maximum Input Delay (OFF-ON):	0.25 second.
Maximum Input Delay (ON-OFF):	0.25 second.
Isolation:	Reinforced safety isolation from any source of hazardous voltages.

15.4 Output Specifications

15.4.1 Output Module Types

Output Option 1 Module Types:	Relay, SSR drive, Triac and DC linear options.
Output Option 2 Module Types:	Relay, Dual Relay, SSR drive, Triac and DC linear options.
Output Option 3 Module Types:	Relay, SSR drive, DC Linear and Transmitter PSU options.

15.4.2 Generic Output Specifications

Relay:	Contact Type:	Single pole double throw (SPDT).
	Control Rating:	2A resistive at 120/240V AC (120V AC for VMD applications). Limit Controller output 1 has fixed 5A latching relay.
	Alarm/EOP Rating:	2A resistive at 120/240V AC
	Control/Alarm Lifetime:	>500,000 operations at rated voltage/current.
	Limit Output Lifetime:	>100,000 operations at rated voltage/current.
	Isolation:	Basic Isolation from universal input and SSR outputs.
SSR Driver:	Drive Capability:	10V minimum at up to 20mA load.
	Isolation:	Not isolated from universal input or other SSR driver outputs.
Triac:	Operating Voltage Range:	20 to 280Vrms (47 to 63Hz).
	Current Rating:	0.01 to 1A (full cycle rms. on-state @ 25°C); derates linearly above 40°C to 0.5A @ 80°C.
	Max. Non-repetitive Surge Current (16.6ms):	25A peak.
	Min. OFF-State dv/dt @ Rated Voltage:	500V/μs.
	Max. OFF-State leakage @ Rated Voltage:	1mA rms.
	Max. ON-State Voltage Drop @ Rated Current:	1.5V peak.
	Repetitive Peak OFF-state Voltage, V _{drm} :	600V minimum.
	Isolation:	Reinforced safety isolation from inputs and other outputs.

Linear DC:	Resolution:	Eight bits in 250mS (10 bits in 1 second typical, >10 bits in >1 second typical).
	Update Rate:	Every control algorithm execution.
	Ranges:	0 to 10V 0 to 20mA 0 to 5V 4 to 20mA 2 to 10V (default)
	Load Impedance:	0 to 20mA & 4 to 20mA: 500Ω maximum. 0 to 5V, 0 to 10V & 2 to 10V: 500Ω minimum. Short circuit protected.
	Accuracy:	±0.25% (mA @ 250Ω, V @ 2kΩ). Degrades linearly to ±0.5% for increasing burden (to specification limits).
	When used as control output:	For 4 to 20mA and 2 to 10V a 2% over/underdrive is applied (3.68 to 20.32mA and 1.84 to 10.16V).
	Isolation:	Reinforced safety isolation from inputs and other outputs.
Transmitter Power Supply:	Power Rating	20 to 28V DC (24V nominal) into 910Ω minimum resistance.
	Isolation:	Reinforced safety isolation from inputs and other outputs.

15.5 Control

Automatic Tuning Types:	Pre-Tune, Self-Tune.
Proportional Bands:	0 (OFF), 0.5% to 999.9% of input span at 0.1% increments.
Automatic Reset (Integral Time Constant):	1s to 99min 59s and OFF.
Rate (Derivative Time Constant):	0 (OFF) to 99 min 59 s.
Manual Reset (Bias):	Added each control algorithm execution. Adjustable in the range 0 to 100% of output power (single output) or -100% to +100% of output power (dual output).
Deadband/Overlap:	-20% to +20% of Proportional Band 1 + Proportional Band 2.
ON/OFF Differential:	0.1% to 10.0% of input span.
Auto/Manual Control:	User-selectable with “bumpless” transfer into and out of Manual Control.
Cycle Times:	Selectable from 0.5s to 512 seconds in binary steps.
Setpoint Range:	Limited by Setpoint Upper Limit and Setpoint Lower Limit.
Setpoint Maximum:	Limited by Setpoint and Scale Range Upper Limit.
Setpoint Minimum:	Limited by Scale Range Lower Limit and Setpoint.
Setpoint Ramp:	Ramp rate selectable 1 to 9999 LSD's per hour and infinite. Number displayed is decimal-point-aligned with display.

15.6 Alarms

Maximum Number of Alarms:	Two “soft” process alarms (high, low, deviation or band) plus Loop Alarm.
Combinatorial Alarms:	Logical OR or AND of alarms to any suitable output.

15.7 Digital Communications

Type:	Asynchronous Serial.
Protocols:	ASCII and Modbus RTU.
Physical Layer:	RS485.
Zone address range:	1 to 99 (ASCII), 1 to 255 (Modbus).
Bit rate:	1200, 2400, 4800, 9600 and 19200 bps.
Bits per character:	ASCII: 10 Modbus: 10 or 11 (depending on parity setting)
Stop bits:	1
Parity:	ASCII: Even (fixed). Modbus: None, even or odd.
Isolation:	Reinforced safety isolation from inputs and outputs.

15.8 Reference Conditions

Ambient Temperature:	20°C ±2°C.
Relative Humidity:	60 to 70%.
Supply Voltage:	100 to 240V AC 50Hz ±1%.
Source Resistance:	<10Ω for thermocouple input.
Lead Resistance:	<0.1Ω/lead balanced (Pt100).

15.9 Operating Conditions

Ambient Temperature (operating):	0°C to 55°C.
Ambient Temperature (storage):	-20°C to 80°C.
Relative Humidity:	20% to 95% non-condensing.
Altitude:	Up to 2000m above sea level.
Supply Voltage:	Either 100 to 240V ±10% AC 50/60Hz or 20 to 48V AC 50/60Hz & 22 to 55V DC
Power Consumption:	5W / 7.5 VA maximum.
Source Resistance:	1000Ω maximum (thermocouple).
PT100 Input Lead Resistance:	50Ω per lead maximum, balanced

15.10 Standards

Conformance Norms:	CE, UL, ULC.
EMC standards:	EN61326*
Safety Standards:	EN61010 and UL3121
Front Panel Sealing:	IP66

Note:

**For disturbances induced by RF fields of 10V/m 80% AM at 1kHz the input accuracy specification is changed to 0.25% in the frequency bands 465 to 575 MHz and 630 to 660 MHz.*

15.11 Physical Specifications

Dimensions:	Depth behind panel:	110mm ($\frac{1}{16}$ DIN instruments). 100mm ($\frac{1}{8}$ & $\frac{1}{4}$ DIN instruments).
	Front bezel size:	48 x 48mm ($\frac{1}{16}$ DIN instruments). 48 x 96mm ($\frac{1}{8}$ DIN instruments). 96 x 96mm ($\frac{1}{4}$ DIN instruments).
Mounting:		Plug-in with panel mounting fixing strap.
Panel cut-out:		45mm x 45mm ($\frac{1}{16}$ DIN instruments). 45mm x 92mm ($\frac{1}{8}$ DIN instruments). 92mm x 92mm ($\frac{1}{4}$ DIN instruments).
Terminals:		Screw type (combination head).
Weight:		0.21kg maximum.

