

Instruction Manual



Anderson Instrument Co. Inc.
156 Auriesville Road
Fultonville, NY 12072
1-800-833-0081
Fax 518-922-8997

Instrument Model Number _____

Instrument Serial Number _____

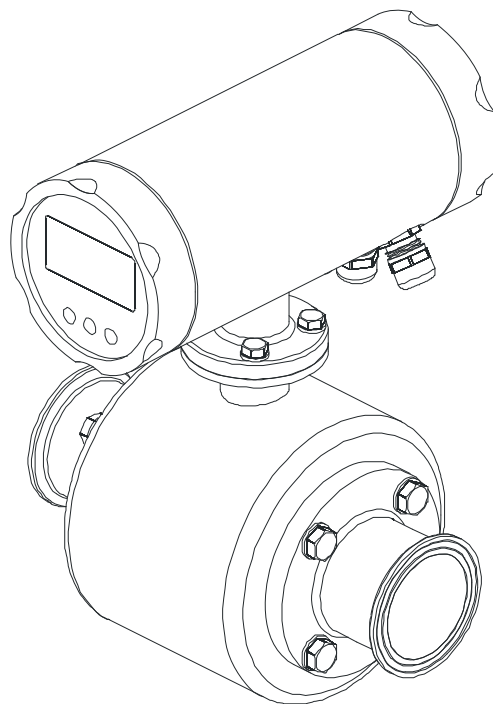

IZMAG Electromagnetic Flow Meter

Form Number AIC2070 ©8/10
Revised: 8/30/10
Supersedes: NEW

Table of contents

| | | |
|-----------|--|-----------|
| 1. | General description | 4 |
| 1.1. | Preface | 4 |
| 1.2. | Structure and Identification of the device | 4 |
| 1.3. | Function | 4 |
| 1.4. | Technical data | 5 |
| 1.4.1. | Converter | 5 |
| 1.4.2. | Transmitter in integral design | 5 |
| 1.4.3. | Measuring ranges and error limits | 6 |
| 1.5. | General remarks | 6 |
| 1.5.1. | Special attention of the user | 6 |
| 1.5.2. | General safety instructions | 8 |
| 1.6. | Intended use | 9 |
| 1.7. | Special safety instructions and devices | 9 |
| 1.8. | Explanation of the safety symbols used | 10 |
| 2. | Transport | 11 |
| 2.1. | General information | 11 |
| 2.2. | Special notes | 11 |
| 2.3. | Dimensions | 12 |
| 2.3.1. | Integral version | 12 |
| 3. | Application | 13 |
| 3.1. | Conditions required for the transmitter | 13 |
| 3.1.1. | Measuring of air and gas | 13 |
| 3.1.2. | Solids | 13 |
| 3.1.3. | Mounting position – electrode axis | 14 |
| 3.1.4. | Inlet and outlet pipe sections | 17 |
| 3.1.5. | Conductivity conditions | 17 |
| 3.1.6. | Interference fields | 17 |
| 3.1.7. | Earthing/grounding conditions | 17 |
| 3.1.8. | Meter tube lining | 18 |
| 3.2. | Flow direction | 18 |
| 3.3. | Conditions required for the converter | 19 |
| 4. | Installation | 20 |
| 4.1. | Installation instructions for the transmitter | 20 |
| 4.2. | Installation instructions for the converter | 21 |
| 4.2.1. | Installation of the electrical power supply | 21 |
| 4.3. | Electrical connection of peripherals | 24 |
| 4.3.1. | Digital output | 25 |
| 4.3.2. | Digital input | 26 |
| 4.3.3. | Analog output - current output | 26 |
| 4.3.4. | CS3-Bus | 27 |
| 5. | Commissioning | 27 |
| 5.1. | General information | 27 |
| 5.2. | Advice for starting-up the IZMAG | 28 |
| 5.3. | Basic settings upon delivery | 28 |
| 5.3.1. | System structure and operating elements | 28 |
| 5.4. | Flow direction | 28 |

Table of contents

| | | |
|--------------|--|-----------|
| 5.5. | Zero point adjustment (“ZERO adjust”) | 29 |
| 5.6. | Metering interruption (assignment of the digital input) | 29 |
| 5.7. | Metering with an empty meter tube | 29 |
| 5.7.1. | Internal "EMPTY pipe detection" | 29 |
| 5.8. | Metering at low conductivities | 29 |
| 5.9. | Use of the internal BUS interface | 30 |
| 6. | Operation | 30 |
| 6.1. | Basic keypad functions | 31 |
| 6.2. | Image navigator | 31 |
| 6.3. | | 33 |
| 6.3.1. | Zero reset of the volume counter..... | 34 |
| 6.3.2. | How to delete malfunction messages..... | 34 |
| 6.3.3. | Parameter change | 34 |
| 6.3.4. | How to release a parameter change: | 35 |
| 6.3.5. | How to release the service functions:..... | 35 |
| 6.3.6. | 36 | |
| 6.4. | Image level: Measured values | 36 |
| 6.4.1. | Measured value: Volume..... | 36 |
| 6.4.2. | Measured value: Flow rate | 36 |
| 6.4.3. | Measured value: Flow rate and volume..... | 36 |
| 6.5. | Image level: Base parameters | 36 |
| 6.5.1. | Language | 37 |
| 6.5.2. | CS3Bus address..... | 37 |
| 6.5.3. | Dimension | 37 |
| 6.5.4. | Profibus address..... | 37 |
| 6.5.5. | Parameter Mode..... | 38 |
| 6.6. | Image level: Pulse output | 38 |
| 6.6.1. | Pulse mode | 38 |
| 6.6.2. | PV1..... | 39 |
| 6.6.3. | TP1..... | 39 |
| 6.6.4. | PV2..... | 39 |
| 6.6.5. | TP2..... | 40 |
| 6.7. | Image level: Digital input | 40 |
| 6.7.1. | Function: Digital input..... | 40 |
| 6.7.2. | IT1 | 40 |
| 6.8. | Image level: Current output | 41 |
| 6.8.1. | Current output mode..... | 42 |
| 6.8.2. | Qmax..... | 42 |
| 6.8.3. | TP3..... | 42 |
| 6.9. | Image level: Metering parameters | 42 |
| 6.9.1. | LFS..... | 43 |
| 6.9.2. | MSPE | 43 |
| 6.9.3. | BSPE | 43 |
| 6.9.4. | Average | 43 |
| 6.9.5. | Offset..... | 44 |
| 6.9.6. | SPAN..... | 44 |
| 6.9.7. | Pipe Detect (recognition of an empty meter tube)..... | 44 |
| 6.9.8. | Nominal width..... | 44 |
| 6.10. | Image level: Special functions | 45 |
| 6.10.1. | Zero adjust | 45 |
| 6.10.2. | Factory setting..... | 45 |
| 6.11. | Image level: Service level | 45 |

Table of contents

| | | |
|--------------|--|-----------|
| 6.11.1. | Error register: Metering | 46 |
| 6.11.2. | Error register: Operating system | 46 |
| 6.11.3. | Simulation of the current output | 46 |
| 6.11.4. | Simulation of the pulse outputs | 46 |
| 6.11.5. | Simulation of the flow rate | 47 |
| 6.12. | Image level: Info | 47 |
| 6.12.1. | Info1 | 47 |
| 6.12.2. | Info2 | 47 |
| 7. | Parameterization | 48 |
| 7.1. | Adjustments | 50 |
| 7.1.1. | Adjustment by calibration factor "m spe" | 50 |
| 7.2. | Measuring accuracy: | 51 |
| 8. | Troubleshooting | 51 |
| 8.1. | Error diagnosis | 51 |
| 8.1.1. | Error diagnosis via the display | 51 |
| 8.1.2. | Error list | 52 |
| 8.2. | Typical effects or error sources | 53 |
| 8.2.1. | Flow without flow rate indication: | 53 |
| 8.2.2. | No pulse transmission despite displayed flow | 53 |
| 8.2.3. | No analog signal available | 53 |
| 8.2.4. | Deviations of measured values | 54 |
| 8.3. | Error reset | 55 |
| 8.3.1. | Visual check | 55 |
| 9. | Maintenance | 56 |
| 9.1. | Safety instructions for maintenance work | 56 |
| 9.2. | Routine maintenance | 56 |
| 9.2.1. | Preventive maintenance steps | 57 |
| 9.3. | Repairs | 58 |
| 9.3.1. | Sending-in the flow meter to the manufacturer | 58 |
| 9.3.2. | Repair Work | 58 |
| 9.4. | Special program functions | 59 |
| 9.4.1. | Flow simulation | 59 |
| 9.4.2. | Simulation via the display unit | 60 |
| 9.5. | Spare parts to be kept available on stock | 60 |
| 10. | Decommissioning | 61 |
| 10.1. | Temporary decommissioning | 61 |
| 10.2. | Final decommissioning / disposal | 61 |

Safety instructions**1. General description****1.1. Preface**

This documentation includes some information protected by copyright. Without prior authorization by **Anderson Instrument Company** this instruction manual is not allowed to be photocopied, copied, duplicated, translated, or recorded on data carriers (neither completely nor in extracts).

This instruction manual should be carefully read before the installation and operation of the device is started. It should be kept in the direct proximity of the device described and readily accessible to all persons concerned.

The safety instructions have to be strictly observed.

Anderson cannot assume any liability or legal responsibility for operating errors caused by the non-observance of these directions.

1.2. Structure and Identification of the device

This instruction manual refers to the integral all-in-one design of the electromagnetic flow meter.

The IZMAG™ is available in the following versions:

operated by DC power supply, integral version

operated by AC power supply, integral version

Integral version:

Transmitter and converter form a single unit.

This instruction manual does not deal with the Weights and Measures-approved versions of the flow meter.

1.3. Function

The electromagnetic flow meter, type IZMAG™, measures both the flow rate and the volume of liquid flows at a high precision.

The measuring device is suitable for measuring conductive liquids.

The IZMAG converter is a microprocessor based device that supplies the transmitter with a switched and regulated coil current.

The signal generated at the electrodes is amplified in the converter, conditioned and shown in the internal measuring registers both as flow rate and volume information.

Volume pulses (pulses per volume unit) are output for controlling and measuring uses.

The instantaneous flow rate is output as an analog signal of 0 or 4...20 mA according to the desired range of 0...100 %.

When leaving the factory, each device is adjusted such that only the power supply and any peripherals will have to be connected.

Safety instructions

1.4. Technical data

1.4.1. Converter

| | |
|---|---|
| Supply voltage: | IZMAG™ DC: 9 - 32 V DC IZMAG™ AC: 100 - 240 V AC, 50/60 Hz |
| Power consumption: | 10 VA max. / 8 watts |
| Electrical fuse connection: | AC power supply: T 500 mA DC power supply: T 1.5 A |
| Digital pulse output: Maximum load: | 3 x galvanically isolated optocoupler output 32 V / 20 mA / pulse sequence: 1 kHz max. |
| Analog output: | 0 or 4 - 20 mA (active or passive), maximum load 500 Ω (optional) 4-20 mA passive output with Hart communication Max.500 Ω load |
| Digital input: | 1 x galvanically isolated optocoupler input; 9 - 32 V, Ri < 3.2 kΩ, activation: 9 - 32V DC, 1 kHz max. |
| Serial interface: | RS485, CS3-Bus protocol |
| Ambient temperature: | -20°C ... +55°C DC power supply -20°C ... +45°C AC power supply |

For further technical data please refer to item 5.3.

1.4.2. Transmitter in integral design

| Transmitter | | Integral version |
|--------------------------------------|-------------|--|
| Process connection: | | Aseptic flange |
| Nominal widths: | | DN 15, 25, 32, 50, 65, 80, 100 |
| Optional product connections: | | Tri-Clamp, Cherry I-line |
| Materials: | Meter tube: | Material no.: 1.4404 / AISI 316 L |
| | Liner: | PFA |
| | Electrodes: | Material no.: 1.4404 / AISI 316 L |
| | Housing: | Material no.: 1.4301 / AISI 304 (micro blasted) |
| Protection class: | | IP67 |
| Electrical connection: | | Internal cable connection Calibration data included in the associated converter |
| Product temperature: | | 100°C max. |
| Cleaning temperature: | | 130°C for a maximum period of 30 minutes |
| Product conductivity: | | 5 µS/cm at a minimum |
| Admissible pressure: | | 0.1 bar absolute at a maximum at 20°C, 10 bar max. |
| Flow velocities: | | 0.1 - 10 m/s |

Safety instructions
1.4.3. Measuring ranges and error limits

| Size | Total measuring range [gal/min] | | | Flow rate at a flow velocity of 1 m/s [gal/min] | Measuring tolerance ± 0.2 % * | | Unit |
|------------|-------------------------------------|---|------|--|-------------------------------------|------|---------|
| | | - | | | > | | |
| 15 | .31 | - | 31 | 2.8 | > | .31 | Gal/min |
| 25 | .80 | - | 80 | 7.8 | > | .80 | Gal/min |
| 32 | 1.3 | - | 130 | 12.8 | > | 1.3 | Gal/min |
| 50 | 3 | - | 300 | 30 | > | 3.0 | Gal/min |
| 65 | 5.2 | - | 525 | 53 | > | 5.2 | Gal/min |
| 80 | 8 | - | 800 | 80 | > | 8.0 | Gal/min |
| 100 | 12 | - | 1200 | 125 | > | 12.0 | Gal/min |

* see measuring accuracy 7.2

Safety instructions

Due to the great variety of possible uses, this instruction manual addresses the general application conditions.

Special cases such as extraordinary ambient conditions or special safety instructions require coordination with the manufacturer.

1.5. General remarks**1.5.1. Special attention of the user**

This measuring instrument has been designed and built in consideration of a risk analysis and after a careful consideration of standards and technical specifications which correspond to a product which is state of the art and offers an optimum in safety.

In practical use, however, that degree of safety can only be obtained when all measures required in this respect will be really taken. It belongs to the user of the flow meter to plan such measures and to check and survey if they are really fulfilled.

In particular, the user has to ensure that:

- The measuring instrument is only used for the intended application as directed (also see the following chapter "Intended use").
- The measuring instrument is operated in a correct and functioning condition and that especially the safety devices are regularly checked for their proper operation.
- The personal protective equipment required for the operating, maintenance, and repair staff is kept available and is used.
- The complete instruction manual in a legible condition is permanently available at the location of the measuring device.
- The device is operated, serviced, and repaired by sufficiently qualified and authorized personnel only.
- The personnel concerned are regularly trained for all applicable questions of the protection of labor and environment and familiarized with the instruction manual and especially the safety precautions included therein.

Safety instructions

- All the safety and warning instructions attached to the measuring instrument are not removed and kept in a legible condition.

In case of problems that cannot be resolved by the user, contact the service department of **Anderson Instrument Co.**

Safety instructions

1.5.2. General safety instructions

These safety instructions have to be strictly observed in order:

- To not endanger the safety of persons and environment
- To avoid any damages to the measuring instrument
- To prevent any faulty batches upon the production

The electric connection may only be carried out by persons who have got the necessary expert knowledge (e.g. trained electrical fitters or persons instructed in electrical engineering) and the necessary authorization from the user.



Unauthorized persons are not allowed to open a housing that shows this symbol!

Warning of dangerous voltage!



Important information

The wiring of the voltage supply and the inputs and outputs of the control circuits has to be carried out professionally in consideration of the up-to-date state of the art. Also refer to **chapter 5** "Installation"/"Electrical Connection".

In particular, the following references have to be observed:

- Safety instructions
 - Electrical connection data
1. All persons who are involved in the installation, commissioning, operation, service, and maintenance of the flow meter have to be qualified accordingly.
 2. This instruction manual has to be strictly observed. The user of the flow meter has to guarantee that the personnel concerned has read and fully understood the instruction manual.
 3. All kinds of work have to be done with utmost care and may be carried out by authorized and trained personnel only.
 4. The instruction manual has to be available close to the flow meter, easily accessible to the operating staff.
 5. Before starting any cleaning, conversion, service or maintenance work, the measuring device has to be switched off and disconnected from the mains power. This requires a device for separating all live wires, e.g. a 2-pole main switch in the control cabinet. The associated device has to be protected against unauthorized switching-on.
 6. Before starting any service and maintenance work, the system has to be flushed with water and emptied. If the flow meter has to be removed from the pipe system, all pipelines will have to be previously emptied and protected by means of some appropriate emptying and shut-off measures.
 7. The flow meter fulfils the general safety requirements according to EN 61010.

Safety instructions

8. Never remove or put out of action any safety devices by modifications to the flow meter!
9. Do not touch any part of the flow tube while the measuring instrument is cleaned. Otherwise, you run the risk of getting burnt!
10. To minimize the danger of injury, the working area of the operator has to allow sufficiently free space.
11. The technical data according to the instruction manual, nameplate and, if available, the performance specification has to be considered.

If damage is done to the meter all warranties are void.

Dangers not resulting from the functionality of the device, but from the ambient and operating conditions prevailing at the place of application, have to be referred to in appropriate instructions to the operators and by the attachment of some danger signs!

The user of the device is exclusively responsible for the compliance with these instructions!

1.6. Intended use

The measuring instrument is only allowed to be used for the application that it has been designed, dimensioned and built for:

- the connection to an earthed monophase network or a direct current network (see the nameplate)
- in industrial areas according to EN 61000-6-2/4 for reasons of EMC

The intended purpose of the electromagnetic flow meter is the measurement of conductive liquids in the food processing industry and in the cosmetic, pharmaceutical and chemical industries.

This flow meter is *not* suitable for the measurement of hazardous, explosive, and combustible liquids of PED group 1.

Any modifications to the measuring device that might have an influence on the function and the safety devices of the flow meter are only allowed to be carried out by the engineering specialists or authorized persons of Anderson.

Possible misuse

Any utilisation being in contradiction to the above-mentioned application means an inadmissible misuse of the measuring instrument! In such a case Anderson does not assume any responsibility for the safety.

Anderson has to be contacted before the flow meter will be used for any different application, and after a careful investigation of all facts Anderson could possibly release the flow meter for the intended new application.

1.7. Special safety instructions and devices

The following dangers could be directly or indirectly caused by the flow meter, type IZMAG, during operation or commissioning:











- Electric shock if the electronic housing is opened improperly
- Burns by touching hot pipe sections

Safety instructions

- Scalds and/or chemical burns by hot liquids or gas coming out through leaking flange connections or because of an inexperienced opening of the pipe system

1.8. Explanation of the safety symbols used

The IZMAG™ flow meters are reliable in operation and meet the highest technical specifications. They leave our factory at a safety-related flawless condition. The devices correspond to the relevant standards and directives according to EN 61010 “Electrical safety testing for measurement and laboratory devices”. However, a hazard can originate from the devices, if they are used inexpertly and not for their intended purpose. Therefore, strictly observe the safety instructions of this instruction manual which are marked by the following symbols:

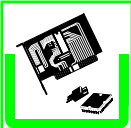
| | | |
|---|--|---|
|  <p>Important information</p> |  <p>Hot caustic solution can cause serious chemical burns</p> |  <p>Caution</p> |
|  <p>Warning of dangerous voltage</p> |  <p>Warning against hand injuries</p> |  <p>Warning against hot surfaces</p> |
|  <p>Warning against hot liquids and steam</p> |  <p>Warning against irritating substances or media detrimental to health</p> |  <p>Warning against an increased risk of skidding in wet areas</p> |
|  <p>Endangered electrostatic component</p> |  <p>Electronic scrap</p> | |

2. Transport

2.1. General information

The following points have to be respected in order to avoid damages to the measuring instrument or injuries during the transport of the device:



Caution

Transport work is only allowed to be carried out:

- By accordingly qualified and authorized persons
- By the aid of appropriate load suspension and fastening devices
- If any risk can be fully excluded while the device is lifted or conveyed

The packing of the measuring instruments is subject to the following labelling:



Fragile goods



Keep dry!

Check the added packing list before you will start opening the packing!
Compare by means of the packing list if all parts are really available or not!
Treat sensitive parts with special care!

Please do not fail to dispose of the packing material according to the appropriate regulations.

2.2. Special notes

When removing the packaging film, see to it that no components of the device (such as display or keypad) are damaged.

2.3. Dimensions

2.3.1. Integral version

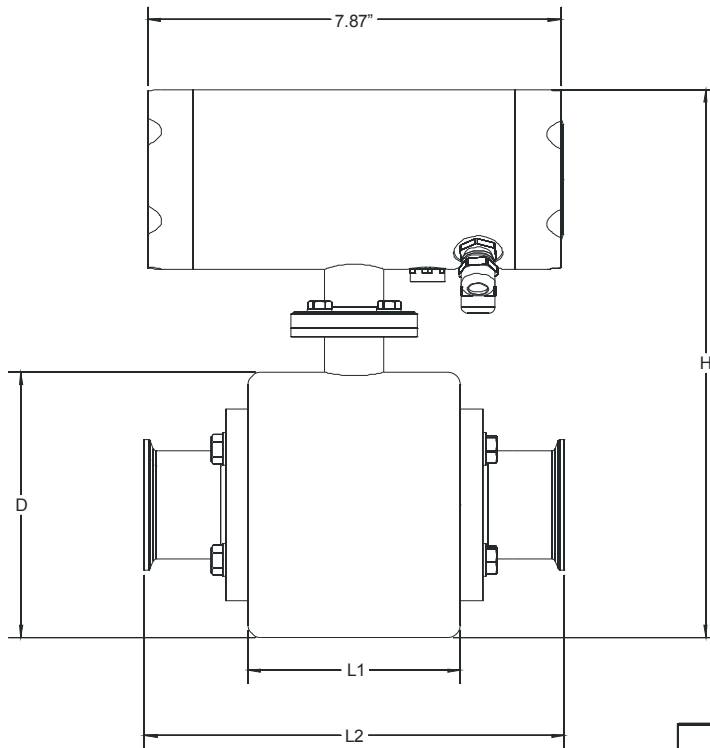

| FLOWTUBE | D | H | L1 | L2 | | |
|----------|-------|--------|-------|-------|-------|--------|
| | | | | A | B | C |
| 3/4" | 3.54" | 8.86" | 4.09" | 8.00" | 9.88" | 13.25" |
| 1" | 3.54" | 8.86" | 4.09" | 8.00" | 9.88" | 13.25" |
| 1-1/2" | 4.13" | 9.45" | 4.09" | 8.00" | 9.88" | 13.25" |
| 2" | 5.12" | 10.43" | 4.09" | 8.00" | 9.88" | 13.25" |
| 2-1/2" | 5.12" | 10.43" | 4.09" | 9.00" | 9.88" | 13.25" |
| 3" | 6.10" | 11.42" | 4.33" | 9.88" | 9.88" | 13.25" |
| 4" | 6.69" | 12.01" | 4.33" | 9.88" | 9.88" | 13.67" |

3. Application

3.1. Conditions required for the transmitter

The transmitter has to be installed in the product line and the converter has to be supplied with voltage.

When selecting the place for the installation of the measuring instrument you should in any rate ensure that the housing can be opened for service work whenever desired and that the flow meter can be simply removed, if necessary.

Cross-flows should be absolutely avoided, as they could cause some damages to the electronic part.



Caution

In order to protect the transmitter against damages, select the place of installation so that:

- the process pressure is always kept within the admissible operating pressure
- the product temperature is always kept within the admissible temperature
- the transmitter is mechanically levelled out (e.g. to avoid vibration)
- the meter tube can be emptied in case of the danger of frost
- the measuring instrument is not arranged straight above a gully or sink hole
- the connection housing is not permanently exposed to dripping water

3.1.1. Measuring of air and gas

The electromagnetic measuring instrument can supply perfect measuring results in case of **gas-free liquids** only. Air locks or deaeration in a liquid will lead to faulty measurements. Thus, make sure that air locks or other possible parts of gas are eliminated before the measuring device e.g. by air eliminators or that deaeration can be excluded by a sufficient working pressure.

The measuring device is not damaged e.g. by air locks.

3.1.2. Solids

Normally, solids do not have any negative influence on the volume measurement. The pipe diameter should always be chosen sufficiently large in order to prevent the meter tube from being clogged in case of products with solid particles.

Due to the fact that the flow velocity of solid matters is usually lower than that of the liquid part of the product, a higher flow fluctuation can be caused while the flow rate is measured.

The measurement of abrasive materials can cause a drifting of the measuring accuracies and, in the end, a deterioration of the transmitter.

Application**3.1.3. Mounting position – electrode axis**

Due to the principle described, the fitting position – to a certain extent – can be selected any way desired. The basic condition for accurate measuring results is, however, a full and gas-free meter tube.

If possible, the electrode axis should be horizontally arranged, in order to avoid a deposition of gas bubbles or solid particles on the surface of the electrodes. Therefore, a slightly ascending pipeline is advisable, preferably with a deaerating possibility at its highest position.

The fitting position should be chosen in such a way that a good readability and handling of the operating unit is guaranteed.

The pipelines within the inlet and outlet pipe sections must not show any unevenness, e.g. welding beads internally.

In the case of 3-A applications, the transmitter **should not** be mounted below the center line of the flow tube.

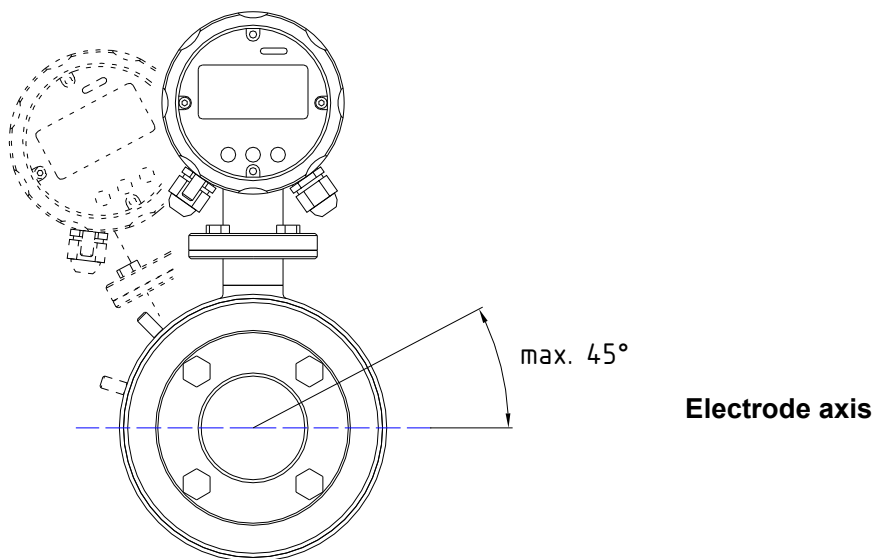

General Installation Requirements

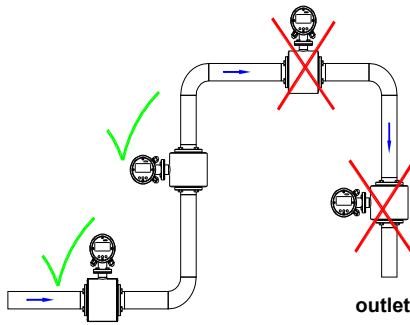

Wrong

At the highest point of the pipeline. Gas bubbles accumulate in the transmitter. → incorrect measurement!

Wrong

Descending pipe:

At the end of the conveyance of the metered product the pipe runs empty. → Measuring errors!

Correct

Preferred mounting position:

Rising pipeline and horizontal pipe section before an

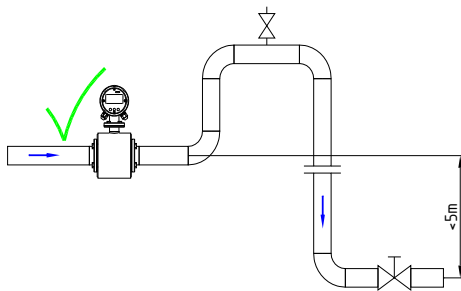

Descending pipelines of a length of more than 5 m have to be equipped with a deaeration valve after the flow meter.

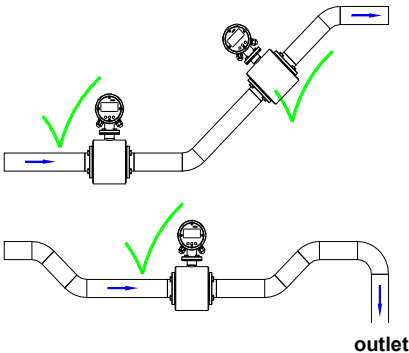

Correct

In case of a horizontal pipe the mounting position is placed in slowly rising section to ensure fill.

Correct

Provide a low spot in the pipe line to maintain pipe line fill.

Installation requirements for 3-A sanitary applications

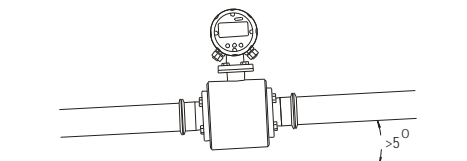

Correct

In horizontal applications a slope of greater than 5 degrees is required to ensure that proper drainage occurs in the pipeline

Other Installation Considerations

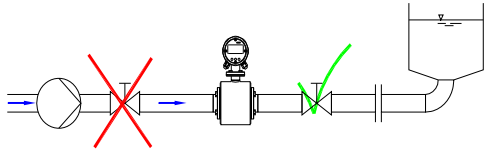

Long lines **after** the flow meter always have to be equipped with a shut-off device. If it is placed before the flow meter, a vacuum will be caused in the metering pipe by the big kinetic energy in the liquid column when shutting off. This can damage the lining of the tube and should be avoided!

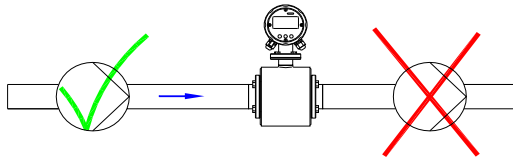

Do not place the flow meter on the suction side of the pump! → **Danger of negative pressure!**

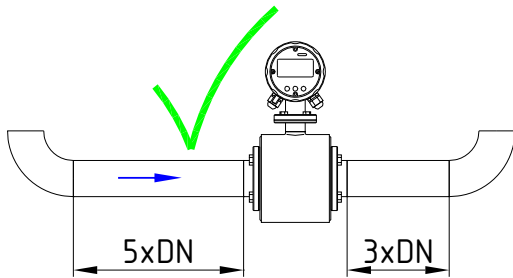

Keep the recommended inlet and outlet sections!

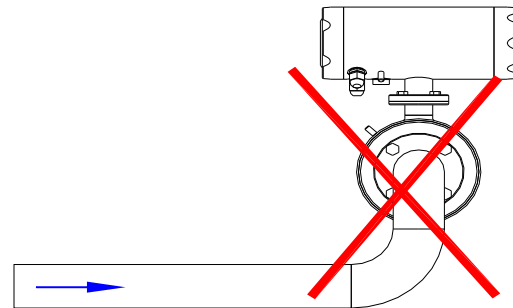

Avoid curvatures of space before the flow meter!

Application**3.1.4. Inlet and outlet pipe sections**

For the installation of electromagnetic transmitters DIN 1944 recommends an inlet pipe section of 5 x DN and, accordingly, an outlet pipe section of 3 x DN in case of an undisturbed flow. For an irregular flow (e.g. distorted rotational flow profile) the inlet and outlet pipe sections have to be extended accordingly or a rectifying device for the flow has to be installed in order to guarantee the specified measuring accuracy.

3.1.5. Conductivity conditions

The liquid to be measured has to show a minimum conductivity of $\geq 5 \mu\text{S/cm}$.

Demineralised water requires a conductivity of $\geq 20 \mu\text{S/cm}$.

A count suppressor for empty meter tubes belongs to the standard equipment of the converter. That function will have to be switched off at conductivities below $50 \mu\text{S/cm}$.

3.1.6. Interference fields

Directly at the transmitter masses of iron or strong permanent or electromagnetic fields must absolutely not exist, as they could influence the defined exciting magnetic field, thus falsifying the signal.

3.1.7. Earthing/grounding conditions

A ideal earthing/grounding of the transmitter is an essential requirement for a reliable and accurate measurement.

“Inductive measuring method” means that the metered liquid itself acts as an electric conductor, i.e. a correct and careful earthing/grounding ensures that no additional potentials will falsify the extremely low metering signal.

For that reason, the earthing/grounding resistance has to be smaller than 10Ω . The earth/ground wire used must not transfer any interference voltages, i.e. no other electric devices must be connected to that line.

In case of a plastic pipe system no equipotential bonding is available between the inlet and outlet sides, it will be necessary to take some appropriate measures for a potential equalisation.

Application

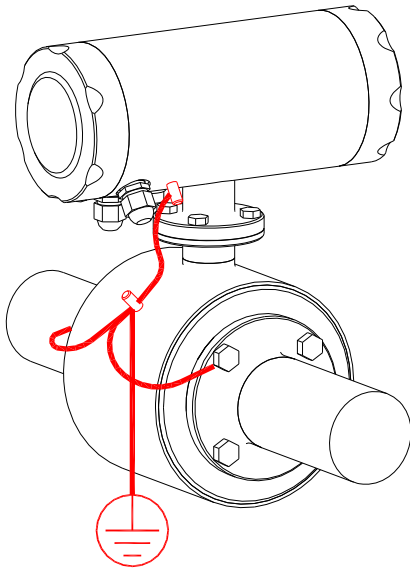

The transmitter has to be earthed/grounded as shown in this picture.

3.1.8. Meter tube lining

A damaged PFA lining can cause faulty measurements or even a failure of the flow meter.

Choose the place of installation in such a way that no negative pressure can be caused, even not when the pump is switched off. An installation at the highest point of the pipeline has to be avoided!

3.2. Flow direction

The arrow on the nameplate shows the calibrated flow direction from MINUS to PLUS.

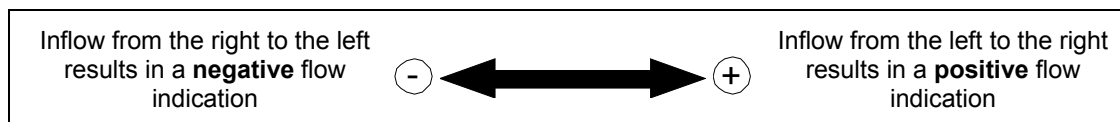

The flow meter can measure in both directions, in principle.

Provided that the recommended inlet and outlet conditions are kept, the accuracy of the measurement in both directions is only slightly different.

3.3. Conditions required for the converter

In order to guard the converter against damages, always select the place of installation so that:

Caution

- the ambient temperature is within a range from $-20...+55$ °C
- the field housing is fastened free from any mechanical distortion
- no moisture can enter the field housing through the cable gland
- the housing is not permanently strained by dripping water

Apart from that, please ensure that the housing can be easily opened for service purposes. The converter has to be installed in such a way that reading and operation of the unit is guaranteed!

4. Installation

Only qualified personnel with the authorization of the user are allowed to carry out the installation work. The qualified personnel have to have read and fully understood this instruction manual and follow all instructions given therein.

The current accepted practices must always be considered during the installation.

The following points should be taken into account after completion of the installation work:

- It has to be checked whether all external supply connections really meet the requirements specified in the technical data of the flow meter (e.g. pressure, temperature, etc.).
- The pipelines have to be flushed before the production is started.
- All external supply joints have to be checked for their safe, leakproof, and nearly stress-free connection to the transmitter.
- The media supplied have to be cautiously adjusted to their required working pressure.
- Occurring leaks have to be removed immediately.
- All electrical lines have to be remote from the flow meter before welding work is started at the pipeline.

The electric wiring of the voltage supply and the inputs and outputs of the control circuits has to be carried out according to the wiring diagram.

4.1. Installation instructions for the transmitter



Caution

Pay attention to the fact that the threaded fittings, clamps, or flanges are correctly tightened! Otherwise, hot or caustic solutions or gasses could come out of the gaps and clearances.

- Leaking liquids can lead to slip hazard.
- Leaking liquids have to be mopped up immediately and disposed of safely.
- If combustible liquids come out, they could cause an explosion hazardous area around that place which has to be marked accordingly.

If the transmitter is connected to existing process lines, those lines have to be unpressurized and free from product.

Do not omit to insert the gaskets into connections!

In case of leaking pipe connections you should check the seals.

After installation of the measuring device you should not fail to ensure optimum earthing/grounding, if some welding work is required.

The best solution is to separate the complete measuring device from the network and to allow an electrically conductive bridging-over of the pipe connections of a possibly large cross section.

Lead the mass electrode of the welding device as close as possible to the welding seam in order to avoid any stray currents within the pipe system and the measuring device!

Always fix the mass electrode of the welding device at the side of the welding seam opposite to the measuring device (in that case the current will flow away from the measuring device)!

4.2. Installation instructions for the converter

When installing the flow meter, pay special attention to the fact that no moisture by drip or splash water can get onto the electronic board.

Metal particles, such as scobs or residues of the shielding braid, have to be removed from the boards before the electric power supply is switched on.

See to it that the pipelines are supported in such a way that no forces and moments are exerted on the measuring device.



Caution

The display must not be exposed to direct sunlight!

4.2.1. Installation of the electrical power supply



Caution

The following safety precautions have to be followed for the execution of the electrical installation work:

This equipment must be connected to a wiring system in accordance with ANSI/NFPA 70, NEC with CSA C22.1, CEC, Part 1

Intended use

The flow meter, type IZMAG, is exclusively destined for:

- The connection to an earthed/grounded monophase network
- The use in industrial areas for reason of EMC (according to definition EN 50 081-2)

Apart from that:

- The supplying system has to guarantee an overvoltage protection for the device according to category II.
- The connection cables have to be secured by a cable strap (AC version) as shown in the photograph on the next page.

Operation

Staff qualification

Necessary work to the flow meter, type IZMAG, is only allowed to be performed by trained and qualified personnel in consideration of the relevant regulations for occupational safety. The flow meter has to be correctly connected according to the electrical wiring diagrams.



Important
information

The nameplate of the flow meter has to be considered for the electrical connection. It is most important that the nominal voltage and the kind of voltage (AC or DC) are equal to those of the flow meter.

The electrical power supply is connected to terminal X1:

Connection of the AC power supply:

L line to X1 / L
N line to X1 / N

Protective conductor to X1 / PE 

Connection cable: ÖPVC-JZ 3G0.75mm², 18 ga. minimum external diameter:
5.7mm

The terminal board is marked by additional AC stickers.

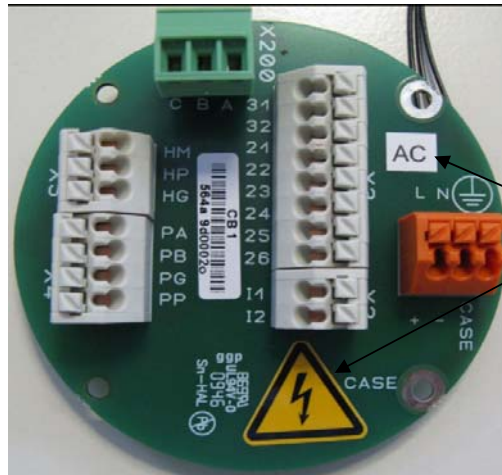

Indicating labels for the AC version

Connection of the DC power supply:

| | | |
|------------------------|----|-----------|
| Positive cable (plus) | to | X1 / + |
| Negative cable (minus) | to | X1 / - |
| Protective conductor | to | X1 / Case |

In case of the DC version the protective conductor has to be connected, too.

Connection cable: ÖPVC-JZ 3G0.75mm² (18ga.), Minimum external diameter: 5.7mm

The terminal board is marked by an additional DC sticker.

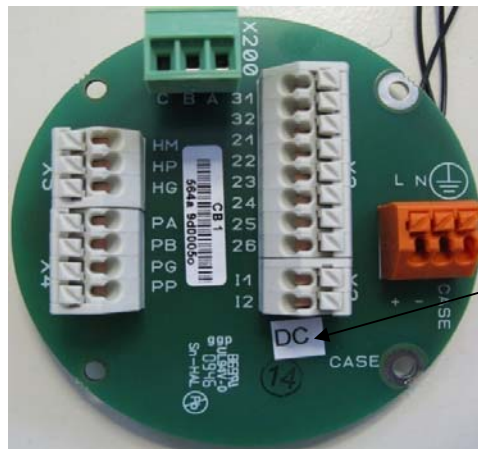

Indicating label for the DC version

The shielding braid has to be correctly connected to the cable gland in order to guarantee an optimum operation of the device according to the EMC directives.



Caution

In case of hard-wired devices without any mains switch it is **absolutely necessary to install a 2-pole switch** or a power switch in the structure of the building. That switch has to be fixed in the direct vicinity of the device, easily accessible to the user and clearly marked as a disconnecting or isolating switch for the device.

This meter can be supplied by different voltages. The supply voltage type and range is indicated on the nameplate.

4.3. Electrical connection of peripherals

The following signal outputs are available:

- 3 x digital outputs, configurable for volume pulses and status output
- 1 x digital input, configurable for measuring interruption or setting to zero
- 1 x analog current output for the flow rate, configurable for:
0...20 mA/active, 4...20 mA/active, and 4...20 mA/passive
- 1 x CS3BUS interface (RS485 interface with AndersonCS3-Bus protocol)

The measured values of the IZMAG™ are usually put out as volume pulses (pulses per gallon) through a digital pulse output:

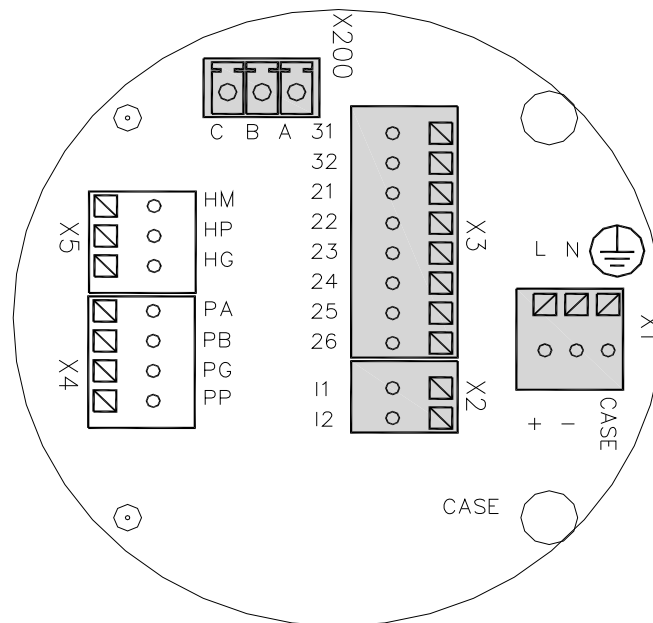

- X200 → CS3BUS, data communication
- X2 → Analog output / current output
- X3 → Digital outputs and digital input
- X1 → Connection of the power supply

4.3.1. Digital output

| Digital output | |
|--|----------------------|
| Hardware | Optocoupler, passive |
| Auxiliary voltage | 32 V max. |
| Output current | 20 mA max. |
| Voltage drop at the optocoupler at 20 mA | 0.5...1 V |
| Output frequency | 1kHz max. |

The following figure shows the basic wiring diagram of the pulse outputs. The outputs switch off in case of overload. By removal of the overload the outputs will be reactivated after a few seconds.

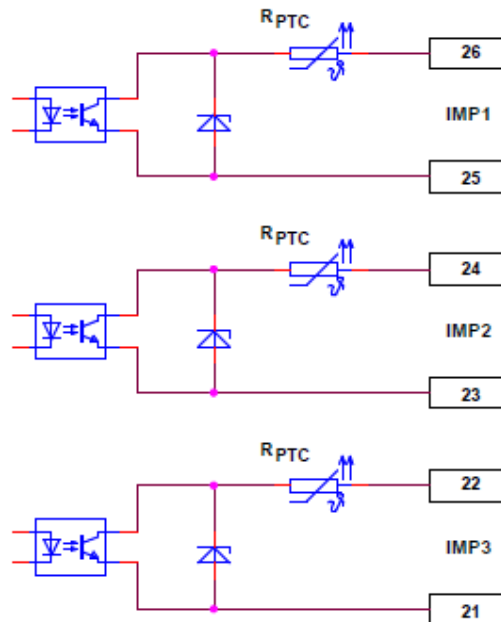
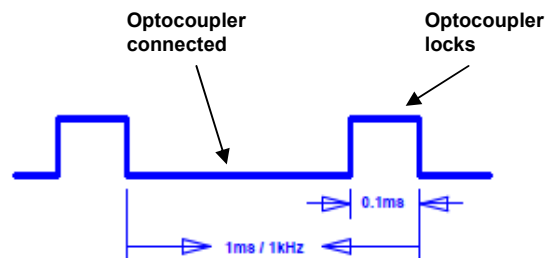

Figure 2: Pin assignment of the pulse outputs



Output signal at 1 kHz

The pulse duty cycle depends on the load, too. An electronic counter has to have an input frequency of at least 5 kHz.

4.3.2. Digital input

| Digital input | |
|----------------------|------------------------------|
| Hardware | Optocoupler, passive |
| Auxiliary voltage | 9...32 V |
| Input resistance | < 3.2 kΩ |
| Input frequency | 1kHz max. |
| Function | Voltage ON → Function active |
| Terminal X3 / No. 32 | Plus |
| Terminal X3 / No. 31 | Minus |

The following figure shows the basic wiring diagram of the control input:

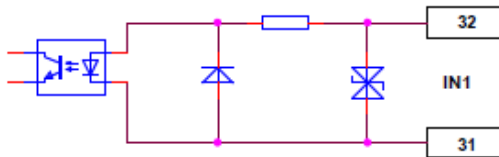

Figure 3: Pin assignment of the digital input

4.3.3. Analog output - current output

| Analog output | |
|----------------|-----------------------|
| Hardware mode | Active or passive |
| Operating mode | 4...20 mA / 0...20 mA |
| Load | 500 Ω max. |
| Error | < 0.2 % |

The analog output works in both flow directions!

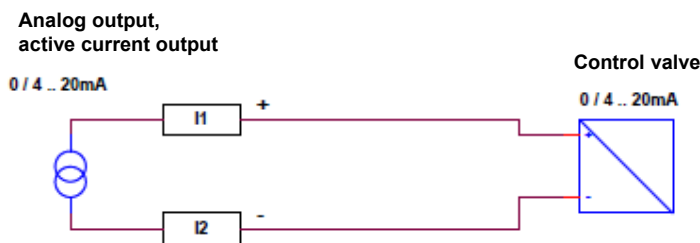

Figure 4: Pin assignment of the active current output

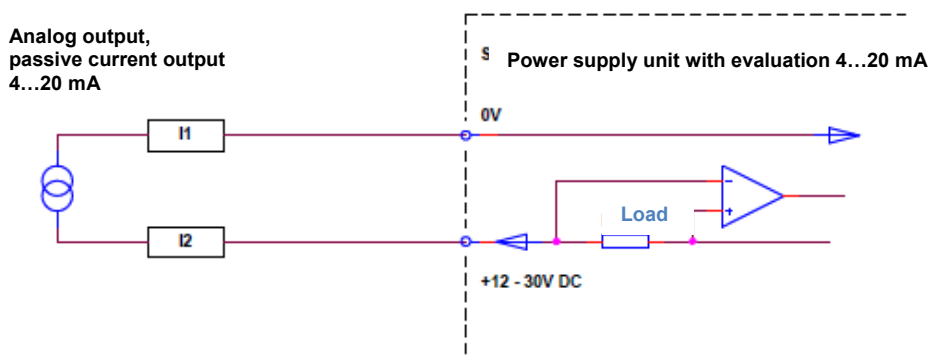

Figure 5: Pin assignment of the passive current output

4.3.4. CS3-Bus

| CS3-Bus | |
|--------------------|---|
| Hardware interface | RS485 |
| Bus protocol | AndersonCS3-Bus protocol |
| Baud rate | 57600 Bauds |
| X200 / A | Signal A |
| X200 / B | Signal B |
| X200 / C | GND |
| Cable length | 100 m max. |
| Cable | LIYCY-0; 4 x 0.5 mm ² , shielded |

The BUS is connected by a 3-pole plug-in terminal with the signals “**A-B-C**”. Further BUS connections are always made 1 to 1, i.e. A is connected to A, B to B, and C to C.

A BUS interface is available for a data communication. It can be used for the connection of the IZMAG™ to the **IVON** service program.

5. Commissioning

5.1. General information

This measuring device may only be operated by trained persons who have got the necessary authorization from the owner of the device. The operators have to be familiar with the process sequence, able to recognize possible dangers, and in a position to take the necessary steps for the removal of accident risks.

Safety measures for the commissioning work



Caution

Both an orderly performed installation and a correct electrical connection are absolute prerequisites for commissioning!

Pay attention to the following points upon the initial start-up of the flow meter:

- Close the housings of transmitter and converter!
 - Personal injury by electric shock can be caused, if the electric lines are touched.
 - Instrument damage can be caused by moisture or metal parts on the electronic unit.
- Ensure that all threaded joints at the measuring instrument and in the direct vicinity are properly tightened.
-

5.2. Advice for starting-up the IZMAG

1. First of all the measuring device has to be installed into the pipeline!

- Pay attention to the flow direction.
- The flow range adjusts itself automatically.
- After the electrical start-up a “**ZERO adjust**” should be carried out by means of the typical liquid to be measured (full meter tube and **no** flow!).

2. How to put into operation the analog output?

- The output can be parameterized specific for the application and it can be operated actively or passively. The current range can be adjusted to 4...20 mA or 0...20 mA. Factory setting: 4...20 mA.
- Dependent on the flow rate, the analog output will produce a current of 0/4...20 mA.
- The 20mA point is determined by setting the “QMAX value of the IZMAG.
- The flow simulation can be used for a functional check.

3. Which other conditions should be taken into consideration?

- Too low product conductivity?
At less than 50 $\mu\text{S}/\text{cm}$, the internal empty-pipe detection has to be switched off by the respective parameter setting.
- Is the analog output too unsteady?
A time constant can be set using the “Average” or TP3 parameters.

5.3. Basic settings upon delivery

At the factory the electromagnetic flow meter is adjusted and delivered with application specific settings as standard.

5.3.1. System structure and operating elements

The electronics are permanently installed in the IZMAG™ converter. The display is arranged on the front above the three optical keys. The electrical connections are on the rear side of the converter.

The status of the device can be read on the display.

5.4. Flow direction

The IZMAG™ measures the flows in both flow directions in principle.

The main flow direction is marked by ⊕ on the transmitter.

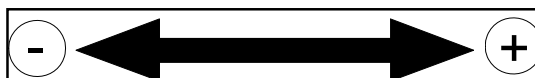

Operation

In the standard setting (output mode 1), the digital outputs release the volume pulses independently of the flow direction.

Negative flows or quantities are displayed with a MINUS sign.

5.5. Zero point adjustment (“ZERO adjust”)

Upon the first start-up of the flow meter it is recommendable to carry out a **zero point adjustment** (“ZERO adjust”) for an adaptation of the flow meter to the conditions prevailing in situ.

Normally, such an adaptation is not required for the integral flow meter version.

ATTENTION! The following conditions have to be observed for a “ZERO adjust”:

- (1) The device has to have reached its working temperature, i.e. it should have been switched on at least 5 minutes before.
- (2) The transmitter has to be completely filled with the typical liquid free of air.
- (3) **No flow** is allowed to occur during the whole “ZERO adjust” measurement.

5.6. Metering interruption (assignment of the digital input)

To externally interrupt the measurement, e.g. during cleaning, a digital signal can be connected to input **IN1** on the terminal board.

The input is activated by a DC voltage between 9 V and 32 V DC at terminal **X3** with PLUS to **no. 32** and MINUS to **no. 31**.

This function has to be switched on by the parameter settings.

5.7. Metering with an empty meter tube

Metrologically accurate flow measurements are only possible, if the meter tube is completely filled with liquid.

In order to avoid an undefined counting in case of an empty meter tube, the IZMAG™ offers both an **internal** and an **external** possibility for measurement suppression:

5.7.1. Internal "EMPTY pipe detection"

The IZMAG™ is equipped with a special “EMPTY pipe detection” (“**pipe detect**”). The setting is made via the parameters. Usually, the EMPTY pipe detection is switched on, i.e. an undefined count will be suppressed in case of an empty meter tube.

At the following situations, the internal EMPTY pipe detection has to be switched off by the parameter setting:

- At a product conductivity of less than 50µS/cm.
- At a heavily pulsating flow (piston, membrane or hose pumps).

5.8. Metering at low conductivities

The IZMAG™ is capable of measuring liquids from a minimum conductivity of 5 µS/cm. In order to obtain perfect results even at conductivities of less than 50µS/cm, the internal “EMPTY pipe detection” has to be switched off in the parameters.

Operation**5.9. Use of the internal BUS interface**

Via the BUS interface it is possible to connect the intelligent AndersonCS3 systems to the IZMAG™.

6. Operation

Only qualified persons with authorization of the user are allowed to operate the IZMAG™.

During normal measurements the operation is restricted to the zero reset of the volume registers. The keypad is dynamically controlled by the image navigator.





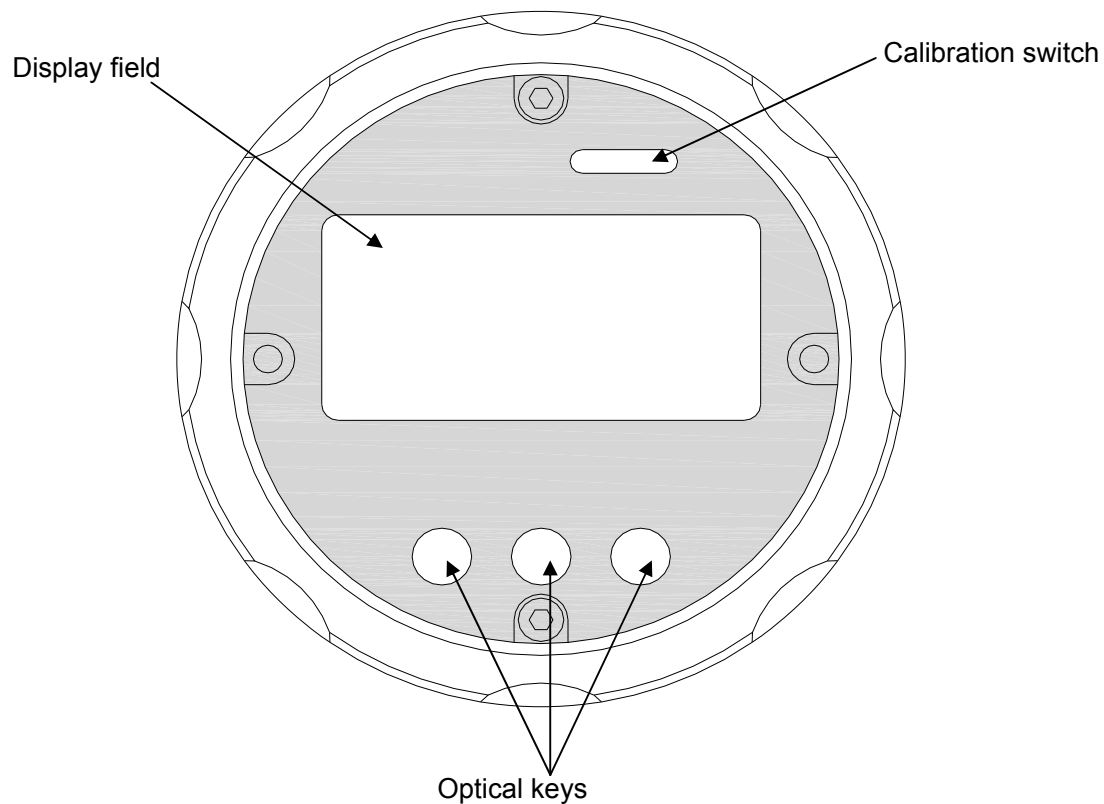

The display unit can be rotated in steps of 90°, thus enabling a proper orientation for viewing and operating the meter.

The display is illuminated by a permanently switched on background lighting which permits a stress free reading.



Elements of the operating unit:

6.1. Basic keypad functions

The keypad consists of 3 optical keys. The functions of the keys are indicated by symbols and texts. The function of the keypad is dynamically controlled by the image navigator:

| | |
|---|--|
|  | To change the main image level |
|  | To return to the main image level or to the measuring image |
|  | To change to the next sub-image |
|  | To reset the volume to zero |
|  | To change the setting parameters, e.g. to change the pulse mode This is only displayed, if the parameter setting is enabled. |
|  | To change the numerical parameters, e.g. low flow quantity This is only displayed, if the parameter setting is enabled. |

Key functions for the value input (numerical parameter):



| | |
|---|-------------------------------------|
|  | Next input position |
|  | Changes the input position |
|  | ENTER, terminates the numeric input |

6.2. Image navigator

The display is divided into **main images** and **sub-images**. Sub-images are allocated to each main image level.

To permit a quick overview of the parameterization the main image shows the most important parameters and settings for the adjustment of the device.

The basic setting of the image navigator is the measured value level where the volume and the flow rate are displayed. A timeout function makes sure that the IZMAG™ always returns to that image level.

The image navigator is controlled by the keys ,  and .

Basic functions of the image navigator:

- Reading the measured values
- Selecting the different functions
- Parameterization
- Service display

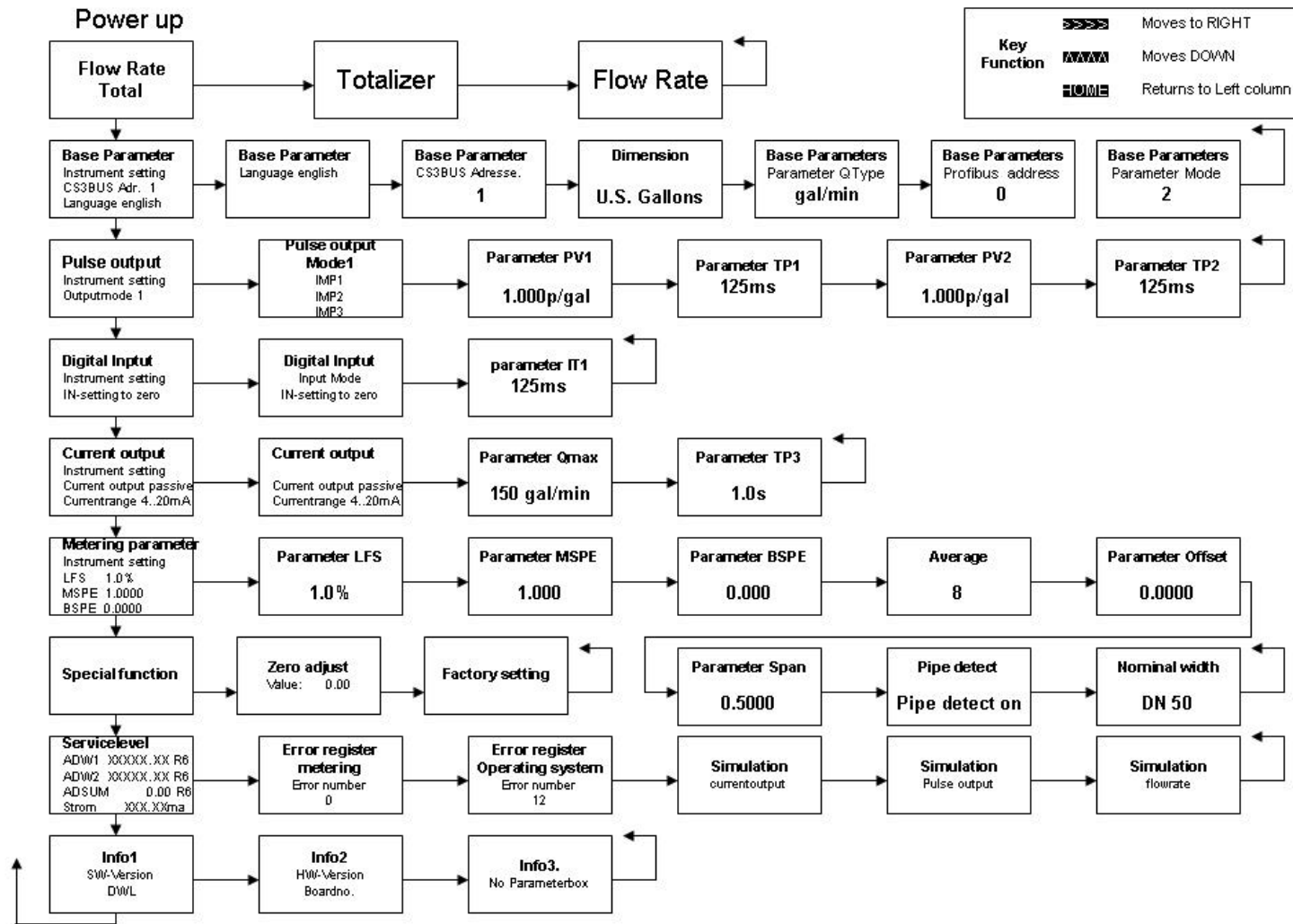

Operation
6.3.1. Zero reset of the volume counter

The main image shows the total. “Zero reset” is a function which can be carried out without any additional activation.

For a zero reset, please keep the **ZERO** key depressed for about 5 seconds.

**6.3.2. How to delete malfunction messages**

Possible malfunction messages are deleted by resetting the volume counter.

6.3.3. Parameter change

There are two kinds of parameters, in principle:

- **Selected parameters**, e.g. pulse mode
- **Numerical parameters**, e.g. TP1

A setting parameter is changed by the **++** key. The **change** key opens an input field for the entry of the numerical parameter selected.

A parameter change is only possible, if it has been unlocked before. Unless it is unlocked, the input of the unlock code is requested automatically.

How to change a numerical parameter:

Press the **change** key and an input field will appear. The instantaneous value is shown inversely, whereas the changeable position is shown as normal.

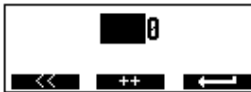

The **++** key changes the digit in the input position. The next left-hand input position is selected by the **<<<** key. If the numerical parameter is set to the desired value, then accept using the **←** key.

How to change a selected parameter:

The procedure is described by means of the example of the “pulse mode”.

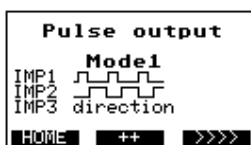

The current pulse output mode is set to “Mode 1”. The next mode is selected and/or adjusted by means of the **++** key.

The next pulse output mode appears on the display.

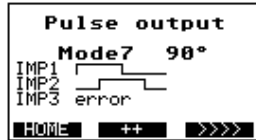

6.3.4. How to release a parameter change:

If a parameter has to be changed and the parameter change is open for change, the display will request the input of the code number.

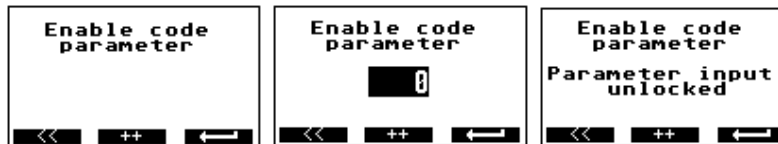

Input the code number as described in item 7.2.3. If the correct code number has been input, the display will show the message "Parameter input unlocked". In case of a wrong code number the display will show "parameter input blocked".

Code number for parameter changes: **222**.

6.3.5. How to release the service functions:

Some service functions have to be released by a code number. Unless they are released, the display will show a request to input the code number.



Input the code number as described in item 7.2.3. If the correct code number has been input, the display will show the message "Service level unlocked". In case of a wrong code number the display will show "Service level blocked".

Code number for the service level: **333**.

6.3.6.

6.4. Image level: Measured values

6.4.1. Measured value: Volume



A 4-seconds long activation of the **ZERO** key will reset the volume to "0".
 The size of the digits is controlled by the size of the measured value.
 The volume indication is the central image that is always shown after a reset.

6.4.2. Measured value: Flow rate



The size of the digits depends on the size of the measured value.

6.4.3. Measured value: Flow rate and volume

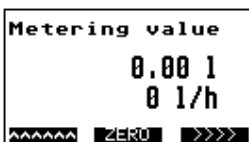

Joint indication of volume and flow rate

6.5. Image level: Base parameters

The image level consists of the following pictures: BE2, BE2S1, BE2S2, and BE2S3.



This image level offers the possibility to make some basic settings. The main image shows the current device setting.

6.5.1. Language



Use the key **++** for changing the language.
You might be prompted to first input an unlock code.

6.5.2. CS3Bus address



The CS3-Bus address can be changed by means of the key **++**.
You might be prompted to first input an unlock code.

6.5.3. Dimension



The **++** key can be used for changing the dimension (unit) of the measured value.
You might be prompted to first input an unlock code.

| Abbreviation | Unit | m dim |
|-----------------|------------------|---------|
| l | Litres | 1 |
| m ³ | Cubic metres | 0.001 |
| hl | Hectolitres | 0.01 |
| ml | Millilitres | 1000 |
| gal | U.S. gallons | 0.2642 |
| gal | Gallons (CDN) | 0.21997 |
| gal | Imp. Gallons | 0.21997 |
| lb | lb raw milk | 2.27189 |
| bbl | beer barrels | 0.00611 |
| dm ³ | Cubic decimetres | 1 |

6.5.4. Profibus address

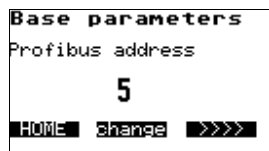

The profibus address can be adjusted by means of the key. **change**

6.5.5. Parameter Mode



The Parameter Mode can be changed by means of the key **++**.

Mode 0 Meter unlocked

Mode 1 Parameter locked until code entry

Mode 2 Parameter always requires code entry

If the parameter switch is locked (to the left) parameter changes are blocked in

Mode 2

You might be prompted to first input an unlock code.

6.6. Image level: Pulse output



This image level serves for the setting of the pulse output. The main image shows the current device setting.

6.6.1. Pulse mode



The pulse mode can be changed by means of key **++**.

You might be prompted to first input an unlock code.

Mode 1 2 independent channels (IMP1 and IMP2) with different values (pv1 and pv2)
 Pulse output independent of the flow direction.
 Maximum pulse length of tp1 and tp2 in ms
 0 ms = pulse-to-pause ratio 1:1.
 Maximum frequency: 1000 Hz.
 IMP3 determines the direction. Positive flow direction: IMP3 is connected.

Mode 5 2 independent channels (IMP1 and IMP2) with different values (pv1 and pv2)
 Pulse output dependent of the flow direction output 1 forward flow, output 2 reverse flow
 Maximum pulse length of tp1 and tp2 in ms
 0 ms = pulse-to-pause ratio 1:1.
 Maximum frequency: 1000 Hz.
 IMP3 determines the direction. Positive flow direction: IMP3 is connected.

- Mode6** 3-channel, shifted by 120°: IMP1, IMP2 and IMP3.
Pulse value: pv1.
Pulse-to-pause ratio: 1:1
Maximum frequency: 333 Hz
In the event of an error IMP2 is switched off.
- Mode7** 2-channel, shifted by 90°: IMP1 and IMP2. Pulse value pv1.
Pulse-to-pause ratio: 1:1.
Maximum frequency: 500 Hz.
In the event of an error IMP3 is connected.

6.6.2. PV1

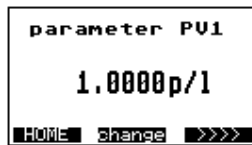

The pulse value PV1 can be changed by the **change** key.
PV1 is valid for Mode1, Mode 5, Mode7 and Mode6.
You might be prompted to first input an unlock code.

6.6.3. TP1



Use the key **change** to change the pulse length of TP1 to ms.
TP1 is valid for Mode1 & 5 only. The value of 0 ms sets the pulse-to-pause ratio to 1:1.
You might be prompted to first input an unlock code.

6.6.4. PV2

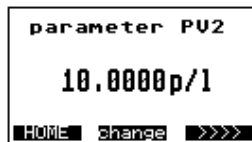

The key **change** can be used to change the pulse value PV2 for the output IMP2.
PV2 is valid for Mode1 and mode 5.
You might be prompted to first input an unlock code.

6.6.5. TP2



By means of the key **change** the pulse length of TP2 in ms can be changed for output IMP2. TP1 is valid for Mode1 & 5 only. The value of 0 ms is used to set the pulse-to-pause ratio to 1:1.

You might be prompted to first input an unlock code.

6.7. Image level: Digital input



The settings for the digital input are made on this image level. The main image shows the current device setting.

6.7.1. Function: Digital input



The function of the digital input can be selected by means of key **++**.

The input can be set to:

- No function
- Count interruption
- Zero setting

The key **++** only appears if the unlock code has been activated before.

You might be prompted to first input an unlock code.

6.7.2. IT1



The **change** key can be used to change IT1 to ms. IT1 determines how long the signal will have to be available for the input to permit the selected function to become active.

You might be prompted to first input an unlock code.

6.8. Image level: Current output

```
currentoutput
Instrument setting
currentoutput passiv
currentrange 4..20mA
AAAAAA [HOME] >>>>
```

On this image level the settings for the current output are made.
The main image shows the current setting of the device.

6.8.1. Current output mode



By this key **++** you can change the mode for the current output.

You can choose among 3 different modes:

- 4 – 20 mA active
- 4 – 20 mA passive
- 0 – 20 mA active

Active / passive - see analog output.

You might be prompted to first input an unlock code.

6.8.2. Qmax



The key **change** can be activated for changing the Qmax value for the current output.

Qmax is the value for 20 mA.

You might be prompted to first input an unlock code.

6.8.3. TP3

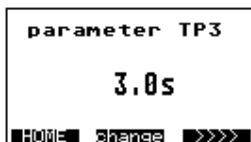

By means of the key **change** you can change the time delay TP3.

The current output is attenuated by this time.

You might be prompted to first input an unlock code.

6.9. Image level: Metering parameters



The settings for the measurement are made on this image level.

The main image partially shows the current device settings.

6.9.1. LFS

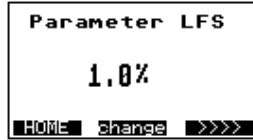

The key `change` can be used to change the low-flow suppression LFS in %. The low-flow volume is calculated from the Qmax value. You might be prompted to first input an unlock code.

6.9.2. MSPE

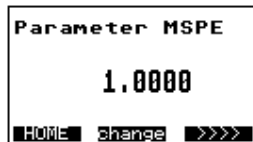

By means of the key `change` you can change the dimensionless factor MSPE. You might be prompted to first input an unlock code.

6.9.3. BSPE

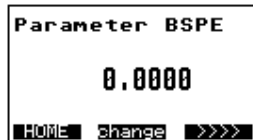

Use the key `change` for changing the dimensionless offset BSPE. You might be prompted to first input an unlock code.

6.9.4. Average



The average value can be changed by means of the key `change`. You might be prompted to first input an unlock code.

6.9.5. Offset

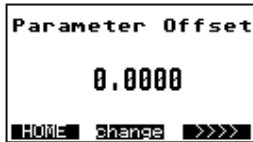

Press the key **change** for changing the Offset value.

The Offset is a calibration value of the sensor which is normally not changed!

You might be prompted to first input an unlock code.

6.9.6. SPAN

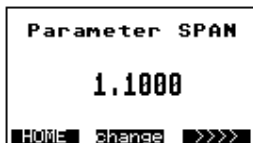

The SPAN value can be changed by the aid of the **change** key.

The SPAN value is a calibration value of the sensor which is normally not changed!

You might be prompted to first input an unlock code.

6.9.7. Pipe Detect (recognition of an empty meter tube)



The empty pipe detection can be switched on and off by means of the **++** key.

You might be prompted to first input an unlock code.

6.9.8. Nominal width

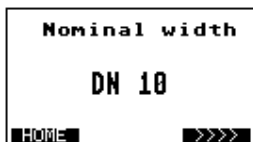

The display shows the nominal width of the transmitter.

6.10. Image level: Special functions



Special functions can be carried out on this image level.

6.10.1. Zero adjust

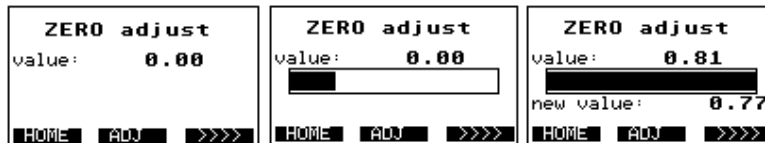

The “ZERO adjust” measurement is activated if the **ADJ** key is depressed for a period of 1.5 seconds. The top line of the display shows the current ZERO value. The course of the bargraph shows the progress of the measurement. The measurement is finished when the bargraph is completely filled. The new ZERO value is displayed below the bargraph and taken over.



Important information

Prerequisite:

The meter tube has to be filled up with the liquid to be measured.

No flow rate is allowed to be available, the liquid rests.

Unless the prerequisites are observed, a faulty ZERO value will be determined and the IZMAG™ will not be able work correctly.

6.10.2. Factory setting



All parameters are reset to the factory setting. After the execution of the function, the image navigator will change back to the image of item 7.9.

You might be prompted to first input an unlock code.

6.11. Image level: Service level



Only service values are displayed and service functions are performed on this service level.

6.11.1. Error register: Metering

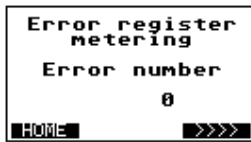

This image shows the error numbers of the measurement.
The error number is reset while the flow meter is set back to zero.

6.11.2. Error register: Operating system

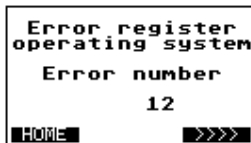

This image shows the error numbers of the operating system.

6.11.3. Simulation of the current output

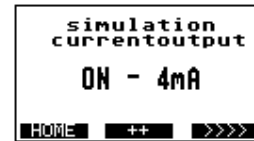

The simulation can be used to check the cable connection or to adjust an analog instrument.

The first value 20 mA is set to 100 % by means of the key **++**. Another activation of the key **++** will set 12 mA, 50 %. After that the key **++** is used for the setting of the value of 4 mA to 0 %. The simulated current value is determined by the current mode, see item 7.7.1. If the setting is 0...20 mA, the simulated values are 20 mA, 10 mA, and 0 mA.

You might be prompted to first input an unlock code.

6.11.4. Simulation of the pulse outputs



This simulation can be used for checking a cable connection or a counting instrument or even a connected controller. According to the output mode, the number of pulses to be simulated is shown in display lines 6 and 7. The simulation is started by the key **++** and a bargraph is displayed. The simulation is finished when the bargraph is completely filled. Then the bargraph is erased.

You might be prompted to first input an unlock code.

6.11.5. Simulation of the flow rate



This function can simulate the complete metrological functionality of the IZMAG™ converter, i.e. the pulse outputs and the current output behave like in the normal operation. This function is suitable for the “dry” commissioning of a system or of system sections.

The **++** key starts the function. The flow reads 0 l/h. Each additional activation of the **++** key increases the flow in steps of 10% of Qmax. The function stops running after the maximum value is reached.

You might be prompted to first input an unlock code.

6.12. Image level: Info

6.12.1. Info1



The Info1 image shows the software versions and the date of the recent software download.

6.12.2. Info2



The Info2 image shows the hardware version and the board number of the main board.

7. Parameterization

At the factory the IZMAG™ is provided with standard parameters (factory settings).



Important
information

Only trained persons authorized by the user of the flow meter are allowed to set and/or change parameters. The persons concerned have to be familiar with the process sequence. They have to be able to recognize possible risks and to take the necessary steps to eliminate dangers of accident.

Take into account that interventions into the parameters of the flow meter carried out while the production is running could lead to undefined reactions!

It is possible to modify the set parameters via the keypad and the display unit in principle.

The following table shows the functions of the different switch positions:

| Parameters | Factory settings | Minimum value | Maximum value |
|----------------------------|--------------------------------|----------------|--|
| CS3Bus address | 32 | 32 | 64 |
| Profibus address | 5 | 0 | 255 |
| Pulse mode | Output mode1 | Refer to: | Pulse mode |
| PV1 | 1.0 | 0.0 | Depending on output mode, dimension and Qmax |
| TP1 | 125 ms | 0 ms | 16000 ms |
| PV2 | Depending on the nominal width | 0.0 | Depending on dimension und Qmax |
| TP2 | 125 ms | 0 ms | 16000 ms |
| Digital input mode | No function | | |
| IT1 | 125 ms | 0 ms | 32000 ms |
| Current output mode | 4 – 20 mA active | Refer to: | Current output mode |
| Qmax 100% for 20mA | Depending on the nominal width | 1.0 | 999999.0 |
| TP3 | 0.2 s | 0.0 s | 30.0 s |
| LFS = Low Flow Suppression | 1.0 % | 0.0 % | 10.0 % |
| MSPE | 1.0 | -1000.0 | +1000.0 |
| BSPE | 0.0 | -1.0 | +1.0 |
| Average | 8 | 1 | 128 |
| Offset | See nameplate | -1.0 | +1.0 |
| SPAN | See nameplate | 0.000001 | 1000.0 |
| Pipe detect | Pipe detect | No pipe detect | Pipe detect |

Table of the abbreviations used and their meaning:

| Abbreviation | Function |
|--------------|--|
| IMP1 | Pulse output 1 |
| IMP2 | Pulse output 2 |
| IMP3 | Pulse output 3 |
| IN1 | Digital input 1 |
| PV1 | Pulse value for IMP1 |
| TP1 | Pulse length for IMP1 |
| PV2 | Pulse value for IMP2 |
| TP2 | Pulse length for IMP2 |
| IT1 | Pulse length for IN1 |
| Q max. | 100% of the flow value for the current output |
| TP3 | Time constant for the current output |
| Dimension | Unit of the volume |
| LFS | Low-flow suppression |
| MSPE | Calibration factor |
| BSPE | Calibration offset |
| Average | Filter of the flow signal (averaging) |
| Offset | Calibration value of the sensor (Do not change!) |
| SPAN | Calibration value of the sensor (Do not change!) |
| Pipe-Detect | Internal EMPTY pipe detection |

Description of the parameter “dimension”

When selecting the volume units “**US gallons**” and “**Litres**” you should take into account, that fixed flow ranges are valid for the “4...20mA” output depending on the nominal width!

List of the STANDARD parameters set for the unit “LIT”

| Designation | Function | Standard | Changeable |
|-------------|--|--------------------------------|-----------------|
| dimension | Unit of volume | Litres | different units |
| lfs | Low-flow suppression | 1.00 % | 0...10% |
| average | Flow signal filter (averaging) | 8 | 64 |
| currmode | Analog output range 0/4 mA | 4 – 20 mA | 0 – 20 mA |
| pipe detect | Internal EMPTY pipe detection | pipe detect | no pipe detect |
| Qmax | 100% flow value for 20 mA | Dependent on the nominal width | |
| pv1 | Value of the volume pulses per litre | 1 | 0,001...99999 |
| tp1 | Pulse length of the digital output | 125 ms | 0 ... 9999 ms |
| tp3 | Time constant for the 4...20 mA output | 1.0 sec | 99 |
| m spe | Calibration factor (-10%...+ 10%) | 1.0000 | 0.900...1.100 |
| b spe | Calibration offset | 0.0000 | ± 0.2000 |

7.1. Adjustments

The IZMAG™ normally needs no adjustment.

Usually, the zero point adjustment (“**ZERO adjust**”) is carried out during the first commissioning only.

If, however, some deviations have to be compensated which were determined e.g. upon a comparison with a calibration vessel or a balance it is possible to make an adjustment via the factor “**m spe**”.

However, before you will start carrying out an adjustment you should have clarified the following questions in any rate:

- Are you sure that the reference standard (reference meter, balance, or calibrated vessel) does really deliver an exactly comparative value?
- Is the limitation of quantities always equal from measurement to measurement?
Take into account that differently emptying pipelines, a missing break-off edge for the liquid or temporary air occlusions will lead to faulty results during the measurement!
- Have the production paths been unlocked? Or are there any manual valves or sampling valves or any cross links possibly open?
- Is the liquid really conveyed during the measurement without any air or gas?
- Are the flow limits kept?
- Is the conductivity of the product within the required tolerance?

An adjustment is only reasonable if similar (reproducible) deviations have been ascertained during the comparative measurements.

7.1.1. Adjustment by calibration factor "m spe"

The adjustment by the calibration factor “**m spe**” can be set via the operating unit.

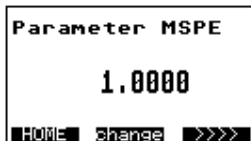

The standard value is set to 1.

The calibration factor is calculated by means of the following formula:

$$\begin{aligned} V_{\text{ref}} &\rightarrow \text{Target volume (e.g. calibration vessel, balance, or the like)} \\ V_{\text{dis}} &\rightarrow \text{IZMAG™ display} \end{aligned}$$

Example:

Deviation ΔF of +0.54% determined during a comparative measurement

Calibration vessel: $V_{ref} = 5000 \text{ L}$

Display: $V_{dis} = 5027 \text{ L}$

$$m_{spe} = \frac{5000}{5027} \cdot 1.0 = \underline{0.9946}$$

7.2. Measuring accuracy:

$\pm 0.2 \% \pm 1 \text{ mm/s}$ under reference conditions

Reference conditions for the determination of the measuring accuracy according to DIN EN 29104 and VDI/VDE 2641:

- Temperature of the measured product: $+28^{\circ}\text{C} \pm 2 \text{ K}$
- Ambient temperature: $+22^{\circ}\text{C} \pm 2 \text{ K}$
- Warm-up period: 30 minutes

Installation:

- Inlet pipe section $> 10 \times \text{DN}$
- Outlet pipe section $> 5 \times \text{DN}$
- Transmitter and converter are earthed/grounded.
- The transmitter is positioned in the centre of the pipeline.

8. Troubleshooting**8.1. Error diagnosis**

The IZMAG™ is equipped with an integrated self-monitoring function. Malfunctions are recognized and automatically removed, if necessary.

8.1.1. Error diagnosis via the display

Displayed messages can support the troubleshooting in case of malfunction or faulty measurement. A distinction is made between error messages for the measurement or for the operating system. The messages are displayed on the service level:

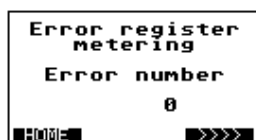

Error message for the measurement

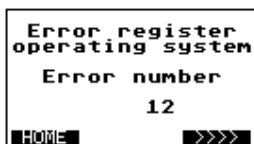

Error message for the operating system

Usually, all displayed messages are erased when the volume is reset to zero. In case of a permanent malfunction, however, the message will be reactivated over and over again.

8.1.2. Error list

| Error No.: | Diagnosis | Remedial actions |
|-------------|---|--|
| 901 | Measurement is continued after an interruption due to: <ul style="list-style-type: none"> - Voltage drop (POWER-FAIL) - Parameter change - Activation of the digital input "IN1" | None |
| 903 | Signal overflow within the electronic unit due to: <ul style="list-style-type: none"> - Too high flow rate (> 12 m/s) - Electrical influences that can occur in case of an empty meter tube - Defective electronics | a. Check the flow rate! b. If the meter tube is empty, a check will be possible with short-circuited electrodes only. |
| 905 | Error found on the occasion of the internal examination of the quantity registers | a. The measuring result can be falsified due to the interference received. <ul style="list-style-type: none"> - Reset the message by resetting the individual quantity to zero! b. Check the whole installation for possible EMC interference sources; frequency converters have to be laid into separate cable channels! <ul style="list-style-type: none"> - Ensure good shieldings and earthings/groundings for all devices! - Use the integral device version for critical installations! |
| 922 | Reference voltage is missing | Replace the converter! |
| 924 | Reference voltage is outside the tolerance | Replace the converter! |
| 928 | Coil current is outside the tolerance | Replace the converter! |
| 932 | No coil current is available | Check the connection of the transmitter! |
| 963 | Pulse output of the output channel IMP1 is exceeded. | <ul style="list-style-type: none"> - Adapt the flow rate! - Reduce the pulse value "pv1"! |
| 964 | Pulse output of the output channel IMP2 is exceeded. | <ul style="list-style-type: none"> - Adapt the flow rate! - Reduce the pulse value "pv2"! |
| 3031 | Parameters of the transmitter cannot be saved. | Replace the converter! |
| 3034 | The calibration parameters of the electronics are faulty. | Replace the converter! |
| 3035 | Free parameters are faulty. | Replace the converter! |
| 3036 | Parameters of the transmitter are defective: Checksum error. | Replace the converter! |
| 3037 | Base parameters for the measurement are faulty: Checksum error. | Replace the converter! |
| 3052 | Meter parameters are faulty: Checksum error. | Replace the converter! |
| 3063 | Pulse value " pv1 " set for the counting output IMP1 is too high (>1000 Hz). | Reduce the pulse value " pv1 "! |
| 3064 | Pulse value " pv2 " set for the counting output IMP2 is too high (>1000 Hz). | Reduce the pulse value " pv2 "! |
| 3070 | One of the calibration factors is set to zero. | Input the respective factor (e.g. SPAN)! |
| 3083 | The "ZERO adjust" measurement has not been accepted. | During the adjustment the flow rate was not "zero". |

Troubleshooting**8.2. Typical effects or error sources**

Disturbances or malfunctions can normally be recognized by the aid of the display unit only.

8.2.1. Flow without flow rate indication:

- (a) Is the conductivity higher than 5 $\mu\text{S}/\text{cm}$?
- (b) Has the internal **EMPTY pipe detection** to be switched off?

Check whether the display shows "0 gal/min" while the flow is running!

If "adsum 0" is displayed, the internal EMPTY pipe detection is active! This is the case, when:

- The conductivity of the liquid is below 50 $\mu\text{S}/\text{cm}$.
- The type of transmitter connected is smaller than DN 15.
- A heavily pulsating flow is present.

To make sure that the electronic part is working correctly, use the existing simulating function (hardware or software) for your further diagnosis of the digital or analog output!

8.2.2. No pulse transmission despite displayed flow

- (a) Check the electric circuit (the IZMAG™ outputs have to be supplied by an auxiliary voltage of 24 V DC)!
- (b) Is the polarity of the pulse counter correctly connected?
- (c) Check the parameters:
 - Is the pulse value too low? (Parameter setting)

Use the simulating function for your further diagnosis (hardware or software)!

8.2.3. No analog signal available

If no analog signal or a faulty analog signal is measured, the following checks are recommended to be carried out:

- a. First the connected measuring system (digital display, PLC or the like) has to be disconnected from the IZMAG™. The analog output signal has to be checked by the simulating function by the aid of an ammeter:
 - If the analog output is ZERO at a 50% simulation, the electronic part is defective, i.e. it will be necessary to replace the complete converter.
 - If the analog output remains constant at 20 mA, the internal "current mode" parameter could be wrong. Verification is possible by means of the operating unit.

- b. If the differences only occur after the disconnection of the external evaluating device, it should be checked:
 - If the burden of the whole current loop is higher than 500 Ω ? (Observe the technical data sheets of the connected devices!)
 - If the input of the external evaluating device is erroneously designed as an “**active**” analog output?
Faults can especially occur upon a connection to a PLC due to the fact that it might both have an “**active**” and a “**passive**” configuration.
- c. If nonlinearities occur over the whole range from 0 - 100%, it should be checked:
 - Whether the burden of the whole current loop is higher than 500 Ω ?

8.2.4. Deviations of measured values

- a) Is there a time-related connection between the occurrence of the problem and some modifications to a system in the vicinity of the measuring device?
- b) Does the deviation show more or less similar values or a constant shift or does it heavily scatter into the positive or negative direction?
- c) Has something been repaired or replaced?
- d) Does the deviation always occur at a certain point of time (e.g. on Mondays at the start of production, on the early shift, or the like) or at certain process steps?
- e) If a display unit is connected, the measuring signals can be checked by means of the service data while the flow is static.
 - Change the display to the presentation of the measured values “adksum” which may be fluctuating between -300 ... +300 units at a maximum.
 - If you carry out several zero point measurements (“ZERO adjust”):
The displayed value is not allowed to change by more than 10 units among the repeated measurements.

Unless stability exists, the earthing/grounding of the transmitter will have to be checked.

The same verification has to be carried out with a full meter tube while the transmitter is removed as a whole. In that status any influences by electrical disturbances or a leaking pipe system can be excluded.
- f) In case of moisture or other faults in the transmitter or converter it will be necessary to replace the measuring instrument with a new one.
- g) Check the pipe path for by-pass lines or air inclusions (faulty seals).

Troubleshooting

h) Check the reference measuring methods or the test procedure (reference meter such as a balance):

- Take into account the temperature compensation of the volume.
- If different products are compared with the value of the balance, the conversion will have to be carried out by means of the density.

Or the same volume differences always occur e.g. at different quantities!

If so, possible reasons could be:

- A start and stop of the measurement while the meter tube is empty.
- An undefined limitation of quantity due to the absence of a break-off edge.
- An undefined dropping-off behaviour due to the absence of an appropriate draining sieve.

i) Low conductivities or pulsating flow upon the use of the internal **EMPTY pipe detection**.

8.3. Error reset

Error messages can be reset:

- By a zero reset of the quantity counter
- Automatically after a maximum period of 30 seconds, unless any further fault did occur.

8.3.1. Visual check

The transmitter can be optically checked while being disassembled:

| Reason | Action |
|------------------------------------|--|
| Humidity in the connection housing | Dry the housing and perform an insulation test subsequently! |
| Damaged PFA liner | Replace the transmitter; check the seal! |

Table: **Visual check**

9. Maintenance

9.1. Safety instructions for maintenance work

Maintenance and repair work must only be carried out by skilled and accordingly trained personnel entrusted with the required authorization from the user.

The persons concerned have to be familiar with the process sequence and be able to recognize possible dangers and to take all necessary steps to remove imminent risks of accidents.



Caution

First ensure your personal safety before you will start carrying out any service and maintenance work!

- Appropriate measures have to be taken to guarantee a safe stability (approved ladders, lifting platforms, safety harnesses, etc.).
- Applicable tools and personal protective measures are necessary.
- Before you start working at electrical or rotating equipment, make absolutely sure that the equipment concerned is disconnected from the power supply network! An unintended restart has to be avoided by suitable safety precautions (e.g. information signs or padlocks).
- Fittings and instruments and their contents can be hot! First permit them to cool down before you will start working at such parts!
- If fittings and instruments have to be removed from the pipe system, the whole pipe system has to be completely emptied, depressurized, and protected by some appropriate shut-off fittings.
- Rinse the pipe system with clear water before the disassembly of fittings or instruments in order to remove possible residuals of chemicals!

9.2. Routine maintenance

On normal operating conditions the flow meter type IZMAG™ does not require any special maintenance work.

Nevertheless, we wish to give you some recommendations for maintenance steps:

Cleaning

Deposits in the meter tube or at the electrodes will cause measuring errors or malfunctions.

Thus, ensure a regular and careful cleaning of both the pipelines and the flow meter!

See to it during the external cleaning that e.g. no high-pressure steam-jets are directed to the housing parts!

In case of flow meters with integrated display the external cleaning temperature must not exceed 50 °C.

The pane of the operating unit should only be cleaned by means of clear water and a soft cloth.

The IZMAG™ transmitter is suitable for CIP.

Regarding the cleaning, disinfecting, and flushing agents and procedures we refer to the manufacturers and the guidelines of the food processing industry.

Seals

That connection seals need periodic replacement.

Accuracy Test

Accuracy tests of the flow meter should be carried out by your in-house quality assurance.

A regular calibration by the Service Engineers of Anderson increases the reliability of the measuring instrument.

9.2.1. Preventive maintenance steps

A regular and careful maintenance of the measuring spot (flow meter in its fitting situation) is indispensable in order:

- To avert any danger for persons and the environment
- Not to endanger the product quality
- Not to reduce the service life of the system and its components

The preventive maintenance steps for the flow meter type IZMAG™ refer to the **seals of the pipe connections**.

The recommended maintenance intervals result from the experience in other systems. However, the actual required maintenance intervals can considerably differ from that experience for the following reasons:

- Daily running time and number of the annual production days
- Aggressiveness of the media
- Frequency of cleaning phases, especially with hot water and caustic solution as well as disinfectants
- Duration and temperature of the cleaning phases
- Possible beginning to dry of product residuals

Anderson recommends checking the measuring spot continuously, i.e.:

The **operators** of the system should **currently** pay attention to:

- occurring leaks
- unusual measuring results

Regular maintenance:

The following are suggestions for determining a maintenance schedule:

1. A replacement of **all** seals and wearing parts in regular intervals, e.g. every year. Exceptions have to be allowed as a matter of course.
2. Replacement of heavier stressed seals and wearing parts in short intervals (e.g. once a year) and of less stressed parts in larger intervals (e.g. every 2 years). It is important that the serviced components are marked accordingly.
3. Exchange of the seals and wearing parts when required (e.g. when leaks occur). On that occasion it is reasonable to replace the wearing parts in the whole adjoining area, especially of the strongly stressed parts. It is indispensable to mark the serviced components accordingly.
4. Accuracy tests of the measuring instruments of the system in regular intervals under the guidance of in-house quality assurance. Otherwise, the meter should be regularly calibrated at the Anderson Instrument.

9.3. Repairs

9.3.1. Sending-in the flow meter to the manufacturer

If repairs have to be carried out at the factory, the following conditions will have to be fulfilled in order to enable a quick and effective repair.

- The components/devices have to be packed in such a way that damage does not occur in shipment.
- An RMA needs to be established with Anderson to identify the meter upon receipt and determine the actions needed by Anderson instrument Company personnel.
- Without the above, delays will occur in the repair process.

9.3.2. Repair Work

Repairs should be restricted to skilled, trained personnel only. Service of the circuit boards should not be attempted. Only complete circuit boards can be exchanged.

For each repair it is indispensable to strictly observe the general maintenance safety instructions.

A replacement of components within the meter should not be done in the installed location for the following reasons:

- Lock washers could drop out and be left on the electronic part when the fastening screws are loosened.
- Metal particles could destroy the electronic part when the power supply is switched on.
- When the electronic housing is open there is the risk that moisture could drip down onto the electronic boards. Moisture immediately destroys the electronic parts when the power supply is switched on.

For all repairs of the flow meter it must be removed from the main power supply!

9.3.2.1. Replacement of the sealing cover of the operating unit

The sealing cover will have to be replaced if the front pane is destroyed or scratched and if the operating unit does not function.

9.3.2.2. Replacement of the transmitter

Before replacing the transmitter, ensure that the pipe system is empty and unpressurized! Flush the pipe system before the removal of the transmitter with clear cold water in order to avoid any residues of chemicals or elevated temperatures.

The distribution voltage for the electronic part has to be switched off.

Carry out a zero point measurement ("**ZERO adjust**") with the new transmitter in order to optimize the accuracy of the flow meter!

9.4. Special program functions

The program of the IZMAG offers some functions that could support a troubleshooting process.

Moreover, it is possible to use those functions for the adjustment and verification of connected devices.

9.4.1. Flow simulation

As an adjusting aid or for diagnosing purposes of connected devices the IZMAG offers the possibility to simulate flow without any flowing product.

9.4.2. Simulation via the display unit

Select the "SIMULATION" function by means of the keypad.

During the simulation the analog output is set to 12.0 mA (4...20 mA setting) or 10.0 mA (0...20mA setting). The volume pulses are produced for the flow of 50 % according to the set pulse value.

9.5. Spare parts to be kept available on stock

The spare parts list results from the experience in the different applications of the flow meter. However, the actually required spare parts may be different from it for the following reasons:

- Daily running time and number of the annual production days
- Aggressiveness of the media
- Frequency of the required cleaning phases, especially with hot water, caustic solution, and disinfectants
- Duration and temperature of the cleaning phases

The following details are absolutely necessary and should never be missing in a spare parts order:

- Quantity and unit
- Description
- Anderson part number

The appendix of this instruction manual includes some lists of wearing parts or spare parts.

10. Decommissioning

10.1. Temporary decommissioning

Should the device be put out of operation for a temporary period only, no special measures have to be observed for its later recommissioning.

If the transmitter is removed out of the process line, the pipe system first has to be emptied and depressurized.

Before removing the transmitter flush the pipe system with clear cold water in order to avoid any residues of chemicals or elevated temperatures.

Attach the covering caps for the protection of the connections.

10.2. Final decommissioning / disposal

If the whole device is defective beyond repair, you should take into account that system components to be scraped will have to be disposed of according to the valid laws and regulations for waste disposal.

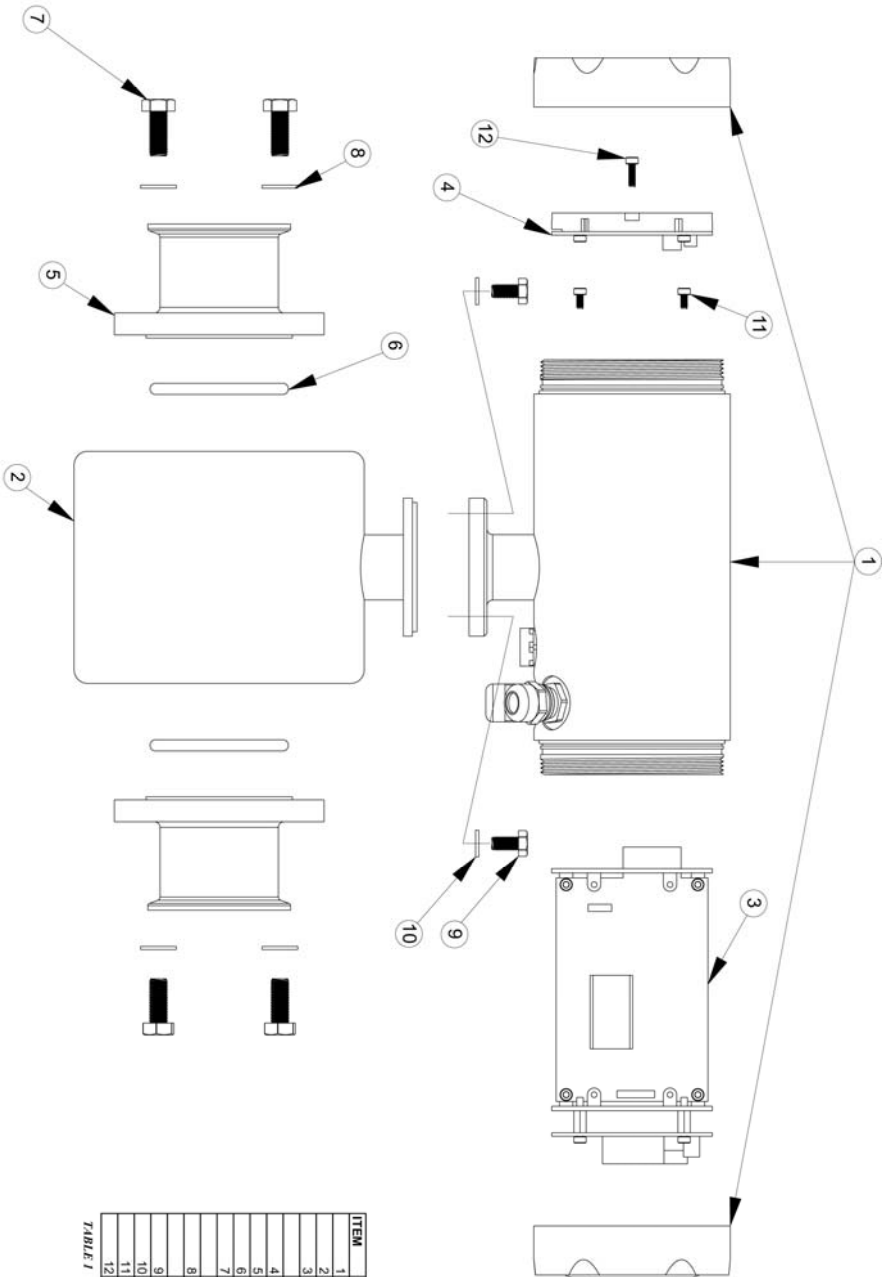

| ITEM | PART NUMBER | DESCRIPTION |
|------|-----------------|----------------------------------|
| 1 | I2MAG-ING-BOC | INTEGRAL HOUSING |
| 2 | SEE TABLE 2 | FLOW TUBE |
| 3 | I2MAG-EL-BOC | AC POWERED ELECTRONICS |
| 4 | I2MAG-EL-DC-BOC | DC POWERED ELECTRONICS |
| 5 | I2MAG-DB-BOC | DISP.LAY BOARD |
| 6 | SEE TABLE 3 | ADAPTOR FANS |
| 7 | SEE TABLE 4 | ADAPTOR O-RINGS |
| 8 | 33720T2009010 | ADAPTOR BOLTS 3/4" THRU 2-1/2" |
| 9 | 45678M1009 | ADAPTOR WASHERS 3/4" THRU 2-1/2" |
| 10 | 45678M0609 | ADAPTOR WASHERS 3/8" & 4" |
| 11 | 33720W060903 | HOUSING BOLTS |
| 12 | 33720W100903 | HOUSING WASHERS |
| | | SCREW |

TABLE 1

| PART NUMBER | DESCRIPTION |
|--------------|------------------|
| I2MAG-015BOC | 3/4" FLOW TUBE |
| I2MAG-025BOC | 1" FLOW TUBE |
| I2MAG-035BOC | 1-1/2" FLOW TUBE |
| I2MAG-055BOC | 2" FLOW TUBE |
| I2MAG-085BOC | 2-1/2" FLOW TUBE |
| I2MAG-100BOC | 3" FLOW TUBE |
| I2MAG-100BOC | 4" FLOW TUBE |

| FLOW TUBE | SHORTEST | 9.88" | 13.25" |
|-----------|------------|------------|------------|
| 3/4" | 56721A0015 | 56721B0015 | 56721C0015 |
| 1" | 56721A0025 | 56721B0025 | 56721C0025 |
| 1-1/2" | 56721A0032 | 56721B0032 | 56721C0032 |
| 2" | 56721A0050 | 56721B0050 | 56721C0050 |
| 2-1/2" | 56721A0065 | 56721B0065 | 56721C0065 |
| 3" | 56721A0080 | 56721B0080 | 56721C0080 |
| 4" | 56721A0100 | 56721B0100 | 56721C0100 |

| FLOW TUBE | O-RINGS |
|-----------|------------|
| 3/4" | 45669A0015 |
| 1" | 45669A0025 |
| 1-1/2" | 45669A0032 |
| 2" | 45669A0050 |
| 2-1/2" | 45669A0065 |
| 3" | 45669A0080 |
| 4" | 45669A0100 |

TABLE 2

Warranty and Return Statement

These products are sold by The Anderson Instrument Company (Anderson) under the warranties set forth in the following paragraphs. Such warranties are extended only with respect to a purchase of these products, as new merchandise, directly from Anderson or from an Anderson distributor, representative or reseller, and are extended only to the first buyer thereof who purchases them other than for the purpose of resale.

Warranty

These products are warranted to be free from functional defects in materials and workmanship at the time the products leave the Anderson factory and to conform at that time to the specifications set forth in the relevant Anderson instruction manual or manuals, sheet or sheets, for such products for a period of two years.

THERE ARE NO EXPRESSED OR IMPLIED WARRANTIES WHICH EXTEND BEYOND THE WARRANTIES HEREIN AND ABOVE SET FORTH. ANDERSON MAKES NO WARRANTY OF MERCHANTABILITY OR FITNESS FOR A PARTICULAR PURPOSE WITH RESPECT TO THE PRODUCTS.

Limitations

Anderson shall not be liable for any incidental damages, consequential damages, special damages, or any other damages, costs or expenses excepting only the cost or expense of repair or replacement as described above.

Products must be installed and maintained in accordance with Anderson instructions. Users are responsible for the suitability of the products to their application. There is no warranty against damage resulting from corrosion, misapplication, improper specifications or other operating condition beyond our control. Claims against carriers for damage in transit must be filed by the buyer.

This warranty is void if the purchaser uses non-factory approved replacement parts and supplies or if the purchaser attempts to repair the product themselves or through a third party without Anderson authorization.

Returns

Anderson's sole and exclusive obligation and buyer's sole and exclusive remedy under the above warranty is limited to repairing or replacing (at Anderson's option), free of charge, the products which are reported in writing to Anderson at its main office indicated below.

Anderson is to be advised of return requests during normal business hours and such returns are to include a statement of the observed deficiency. The buyer shall pre-pay shipping charges for products returned and Anderson or its representative shall pay for the return of the products to the buyer.

Approved returns should be sent to:

ANDERSON INSTRUMENT COMPANY INC.
156 AURIESVILLE ROAD
FULTONVILLE, NY 12072 USA

ATT: REPAIR DEPARTMENT



ANDERSON INSTRUMENT CO., INC • 156 AURIESVILLE RD. • FULTONVILLE, NY 12072 • USA • 800-833-0081 • FAX 518-922-8997
ANDERSON INSTRUMENT CO. LP • 400 BRITANNIA RD. EAST, UNIT 1 • MISSISSAUGA, ONTARIO L4Z 1X9 • CANADA • 905-568-1440 • FAX 905-568-1652
NEGELE MESSTECHNIK GmbH (A Division of Anderson) • RAIFFEISENWEG 7 • D-87743 EGG A. D. GÜNZ • GERMANY • +49 (0) 8333/9204-0 • FAX +49 (0) 8333/9204-49

www.andinst.com