



FLOW
LEVEL
PRESSURE
ANALYTICAL
TEMPERATURE
INSTRUMENTATION
PASTEURIZATION CONTROLS

Electrodeless Conductivity Sensors

- **NEMA 4X stainless steel sensor housing**
- **Electrodeless design eliminates polarization and electrode coating problems**
- **PFA Teflon®-coated probe operates at temperatures up to 392°F or 200°C**
- **Wide measuring range from 0-200 up to 0 - 2,000,000 microSiemens/cm**
- **NEMA 4X analyzer allows multiple measurements along with built-in concentration tables viewable via a clear back-lit LCD display**
- **3-A compliant; Third party verified in accordance with standard 74-02**

Anderson's Model HC1 Electrodeless Conductivity Sensors are rugged, non-fouling sensors designed for cleaning solutions with conductivity ranges from 0-200 up to 0-2,000,000 microSiemens/cm and temperature compensated over a range of 0° and 200°C. Because these sensors are electrodeless and PFA Teflon® coated, there is no instance of polarization, process coating or contamination. For greatest performance accuracy, the HC1 can be installed in a standard

2-1/2" x 2" or 3" x 2" short outlet reducing tee, or can be ordered with our 2" x 2" special Inductive Conductivity Sensor sanitary tee.

Used in conjunction with our inductive conductivity sensors, the DA1 is Anderson's panel-mount, 1/4 DIN Electrodeless Conductivity Analyzer specifically designed for CIP systems within the dairy, fluid food, beverage and/or biopharmaceutical markets.

Alternatively, users may

specify Anderson's DA2 conductivity transmitter. With an operator interface identical to that of the Analyzer, the NEMA 4X enclosed transmitter may be panel, wall, pipe or integral sensor mounted.

Detailed specifications and ordering information can be found on the reverse. For more information, visit our website, or contact our Customer Service Department at 1-800-833-0081.



Specifications

Operational (HC1 Sensor)

Wetted Materials:	PFA Teflon® (Complies with 3A)
Operating Temperature Range:	14° to 392°F (-10° to 200°C)
Maximum Flow Rate:	10ft. (3m) per sec.
Measuring Range:	From 0-200 to 0-2,000,000 microSiemens/cm
Temperature Compensator:	Pt 1000 RTD
Sensor Cable:	5-conductor (plus two isolated shields) cable with Teflon®-coated jacket; rated to 392°F (200°C); 20 ft. (6m) long
Pressure Temperature Limits:	200 psi at 392°F
Mounting:	2" Tri-Clamp® process connection for mounting in: 2" x 2" special tee (73223-A0001) 2-1/2" x 2" short outlet reducing tee 3" x 2" short outlet reducing tee
Wiring Style:	Sealed cable with Strain Relief, or Sealed cable with male 1/2" NPT & Strain Relief

Operational (DA1 Analyzer and DA2 Transmitter)

Display:	Two-line by 16 character LCD
Measurement:	<u>Selectable Ranges</u>
Conductivity:	µS/cm: 0-200.0 or 0-2000 mS/cm: 0-2.000, 0-20.00, 0-200.0 or 0-2000 S/cm: 0-2.000
% Concentration:	0-99.99% or 0-200%
TDS:	0-9999 ppm
Temperature:	-4 to 392°F (-20 to 200°C)
Analog Outputs:	0.00-20.00 mA or 4.00-20.00mA
Ambient Conditions:	-4 to 140°F (-20 to 60°C); 0-95% relative humidity, non-condensing
Temperature Compensation:	Automatic from 14.0° to 392°F (-10°C to 200°C), with selection for Pt 1000 Ohm RTD temperature element or manually fixed at a user selected temperature
Memory Backup (non-volatile):	All settings retained indefinitely in EEPROM

Performance (DA1 Analyzer)

Accuracy:	± 0.5% of span
Sensitivity:	± 0.2% of span per 24 hours, non-cumulative
Repeatability:	± 0.1% of span or better
Temperature Drift:	Zero and span: less than 0.02% of span per °C

Mechanical (DA1 Analyzer)

Panel Mount:	1/4 DIN, polycarbonate with NEMA 4X (IP65) front panel; hardware included for panel mounting
Wall Mount (optional):	7.5" w X 7.5" h X 6.22" d (191mm X 191mm X 158mm) fiberglass reinforced polyester with mounting flange and NEMA 4X, (IP65) rating

Electrical (DA1 Analyzer)

Operating Voltage:	90-130 VAC, 50/60 Hz (10 VA max.) or 190-260VAC, 50/60 Hz (10 VA max.)
Outputs (Relay):	Two (2) electromechanical relays; SPDT (Form C) contacts; UL rated 5A 115/230 VAC, 5A @30 VDC resistive
Outputs (Analog):	Two (2) isolated 0/4-20mA outputs; each with 0.004 mA (12 bit) resolution and capability to drive up to 600 Ohm loads

Performance (DA2 Transmitter)

Accuracy:	± 0.1% of span
Sensitivity:	± 0.05% of span
Repeatability:	± 0.05% of span
Temperature Drift:	Zero and span: ± 0.02% of span per °C
Response Time:	1-60 sec. to 90% of value upon step change (with sensor filter setting of zero)

Mechanical (DA2 Transmitter)

General:	Polycarbonate; NEMA 4X (IP65) general purpose; choice of panel or wall/pipe/integral mounting hardware
Panel Mount:	3.75" w X 3.75" h X 0.75" d (95mm X 95mm X 19mm)
Wall /Pipe/Integral:	3.75" w X 3.75" h X 2.32" d (95mm X 95mm X 60mm)

Electrical (DA2 Transmitter)

Operating Power (Class 2 Power Supply)	
Two-wire hookup:	16-30 VDC
Three-wire hookup:	14-30 VDC
Four-wire hookup:	12-30 VDC
Output (Analog)	One (1) isolated 0/4-20mA output; with 0.004 ma (12 bit) resolution

NOTE: These typical performance specifications are:

- 1 Based on 25°C with conductivity of 500 µS/cm and higher. Consult Anderson Instrument for applications in which conductivities are less than 500 µS/cm.
- 2 Derated above 100°C to the maximum displayed temperature of 200°C. Consult Anderson Instrument for details.

How To Order

SENSOR

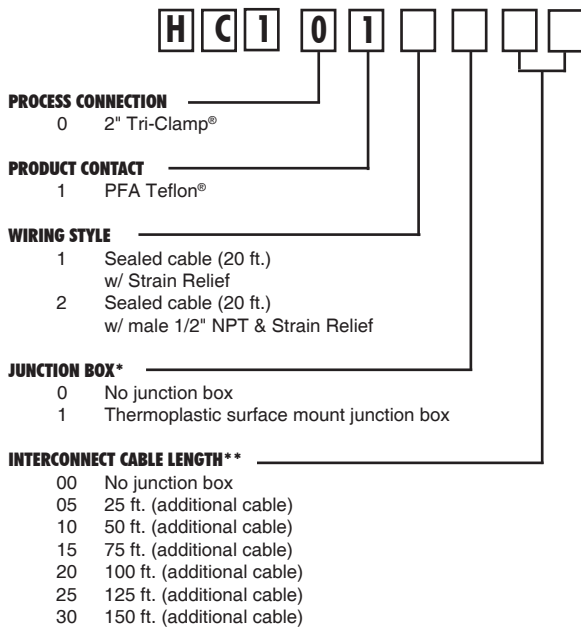

ACCESSORIES

73223A0001 2" Inductive Conductivity Sensor Sanitary Tee

NOTES:

- * Junction box required where interconnect distances of more than 20 ft. (6m) are required.
- ** This 6-conductor must be used to connect between the junction box and the receiver.

ANALYZER

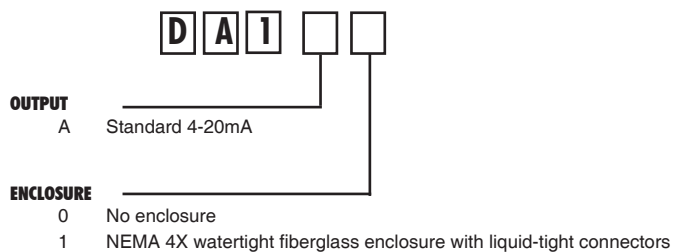

ACCESSORIES

53433A0001 Fuse Kit - Includes two (2) replacement fuses and a bezel

TRANSMITTER

