

VALVES & EQUIPMENT



FOCUS
on a world
of advanced technology



DEFINOX

Butterfly valves DPX - DPAX

FEATURES

- Reliable and economical technology
- Quick assembly and disassembly
- Can be used for a variety of applications
- Low pressure loss and line transfer without retention
- Easy to adjust operating devices

SPECIFICATIONS

DIMENSIONS

- SMS - DIN - US
from DN 25 (1") to DN 150 (6")

MATERIALS

- Half body: stainless steel 316L
 Disc: stainless steel 316L
 Seal: EPDM - Fluorinated elastomer (FKM) or silicon
 Operating devices: stainless steel 304

CONNECTIONS

- | CONNECTION TYPES | STANDARDS |
|------------------|-------------------------|
| To weld | SMS - DIN - US standard |
| Threaded | SMS - DIN |
| Liner-nut | SMS - DIN |
| Clamp | US standard |

OPERATING DEVICES

- MANUAL - DPX**
 Right-opening standard or trigger handle
 Left-opening standard or trigger handle
 Simple adjusting handle
 Micrometric handle

AUTOMATIC - DPAX

- Single or double acting valve actuator

SIGNALLING EQUIPMENT

- Visible on single or double stainless steel bracket
 Point-to-point or AS-i control unit
 ICS (from DN 25 to DN 150)
 ACS (from DN 25 to DN 150)

SURFACE CONDITIONS

- RA exterior = 1.2 µm (150 grit)
- RA interior = 0.8 µm (180 grit)

SERVICE CONDITIONS

- Max. temperature: + 120°C (temperature depending on seal type)
- Min. temperature: 0°C
- Working pressure: from 4 to 10 bar (400 to 1000 kPa) depending on diameter
- Actuator air supply pressure: min. 5.5 bar (550 kPa) - max. 8 bar (800 kPa)
- Vacuum resistance: 0.4 cm³/s

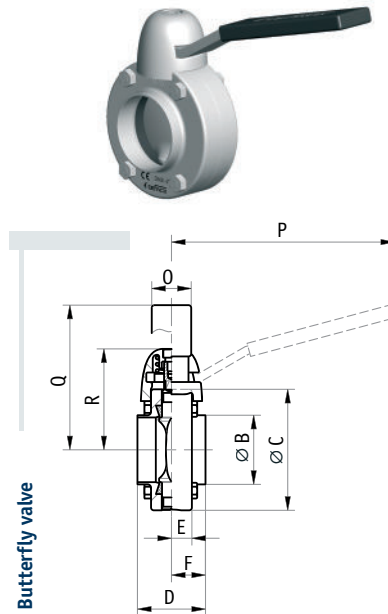

DPX manual - standard handle



DPX manual - trigger handle

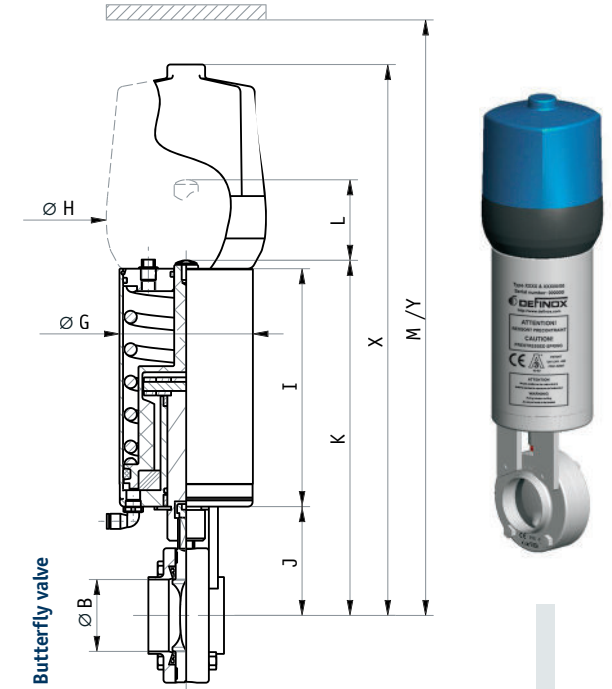

DPAX automatic

Tube ØB	ØC	D	E	F	ØG	ØH	I	J	K	L	M	O	P	Q	R	X	Y	Weight in Kg	
																		(stroke)	(without unit)
SMS 22.6/25	79	50	15	25	89	104	157	67	231	53	304	30	165	100	70	341	371	1.4	4.6
SMS 30/32	79	50	15	25	89	104	157	67	231	53	304	30	165	100	70	341	371	1.3	4.5
SMS 35.6/38	79	50	15	25	89	104	157	67	231	53	304	30	165	100	70	341	371	1.3	4.5
SMS 48.5/51	89	50	15	25	89	104	157	73	237	53	310	30	165	105	75	347	377	1.6	4.8
SMS 60.3/63.5	104	50	15	25	89	104	157	82	246	53	319	30	165	112	83	356	386	1.7	4.9
SMS 72/76	119	50	15	25	89	104	157	91	255	53	328	30	165	120	91	365	395	2	5.2
SMS 100/104	149	58	19	29	115	140	174	101	285	53	363	35	260	155	112	410	445	4.1	9.9
DIN 26/28	79	50	15	25	89	104	157	67	231	53	304	30	165	100	70	341	371	1.4	4.6
DIN 32/34	79	50	15	25	89	104	157	67	231	53	304	30	165	100	70	341	371	1.3	4.5
DIN 38/40	79	50	15	25	89	104	157	67	231	53	304	30	165	100	70	341	371	1.3	4.5
DIN 50/53	89	50	15	25	89	104	157	73	237	53	310	30	165	105	75	347	377	1.6	4.8
DIN 66/70	119	50	15	25	89	104	157	91	255	53	328	30	165	120	91	365	395	2.1	5.3
DIN 81/85	129	58	19	29	89	104	157	90	274	53	352	30	165	145	101	381	434	3.4	9.2
DIN 100/104	149	58	19	29	115	140	174	101	285	53	363	35	260	155	112	410	445	4.1	9.9
DIN 125/129	179	58	19	29	115	140	174	116	300	53	383	35	260	170	128	425	465	4.5	10.3
DIN 150/154	204	58	19	29	114	140	173	129	312	53	395	35	260	190	140	437	480	5.6	12
US 1" (22.1/25.4)	79	50	15	25	89	104	157	67	231	53	304	30	165	100	70	341	371	1.4	4.6
US 1 1/2 (34.8/38.1)	79	50	15	25	89	104	157	67	231	53	304	30	165	100	70	341	371	1.3	4.5
US 2" (47.5/50.8)	89	50	15	25	89	104	157	73	237	53	310	30	165	105	75	347	377	1.6	4.8
US 2 1/2 (60.2/63.5)	104	50	15	25	89	104	157	82	246	53	319	30	165	112	83	356	386	1.7	4.9
US 3" (72.9/76.1)	119	50	15	25	89	104	157	91	255	53	328	30	165	120	91	365	395	2	5.2
US 4" (97.4/101.6)	149	58	19	29	115	140	174	101	285	53	363	35	260	155	112	410	445	4.1	9.9
US 6" (146.9/152.4)	204	58	19	29	114	140	173	129	312	53	395	35	260	190	140	437	480	5.6	12

Interflange butterfly valves DPX EB - DPAX EB

FEATURES

- New compact interflange valve design
- O-rings that seal between the half bodies and the flange
- Quick assembly and disassembly
- Can be used for a variety of applications
- Low pressure loss and line transfer without retention
- Easy to adjust operating devices

SPECIFICATIONS

DIMENSIONS

- SMS - DIN - US
from DN 25 (1") to DN 150 (6")

MATERIALS

- Half body: stainless steel 316L
- Disc: stainless steel 316L
- Weld end: stainless steel 316L
- Seal: EPDM - Fluorinated elastomer (FKM) or silicon
- Flange and fastening: stainless steel 304
- Operating devices: stainless steel 304

OPERATING DEVICES

MANUAL - DPX

- Left standard or trigger handle
- Right standard or trigger handle

AUTOMATIC - DPAX

- Single of double acting valve actuator

SIGNALLING EQUIPMENT

- Visible on single or double stainless steel bracket
- Point-to-point or AS-i control unit
- ICS (from DN 25 to DN 150)
- ACS (from DN 25 to DN 150)

SURFACE CONDITIONS

- RA exterior = 1.2 µm (150 grit)
- RA interior = 0.8 µm (180 grit)

SERVICE CONDITIONS

- Max. temperature: + 120°C (temperature depending on seal type)
- Min. temperature: 0°C
- Working pressure: from 4 to 10 bar (400 to 1000 kPa) depending on diameter
- Actuator air supply pressure: min. 5.5 bar (550 kPa) - max. 8 bar (800 kPa)
- Vacuum resistance: 0.4 cm³/s



Interflange butterfly valve

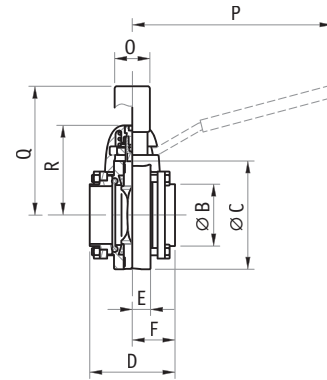

DPX EB manual

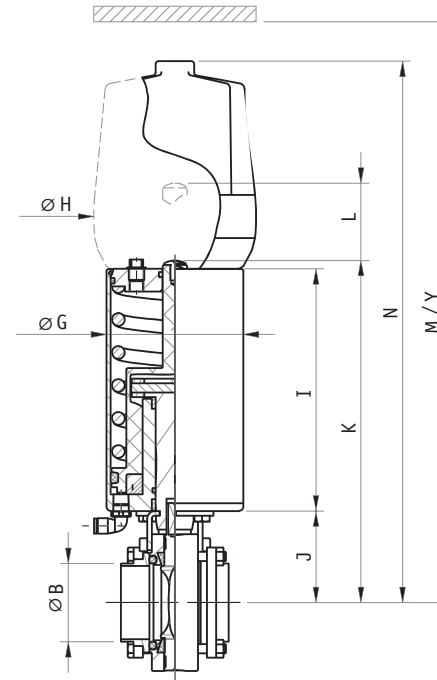

Interflange butterfly valve

DPAX EB automatic



Tube ØB	ØC	D	E	F	ØG	ØH	I	J	K	L		N	O	P	Q	R	Y	Weight in Kg	
										(stroke)	(without unit)							(with unit)	DPX
SMS 22.6/25	79	68	15	34	89	104	157	55	218	53	291	347	30	165	100	70	371	1.8	5.1
SMS 30/32	79	68	15	34	89	104	157	55	218	53	291	347	30	165	100	70	371	1.6	5
SMS 35.6/38	79	70	15	35	89	104	157	55	218	53	291	347	30	165	100	70	371	1.8	4.9
SMS 48.5/51	89	70	15	35	89	104	157	60	223	53	296	352	30	165	105	75	377	1.8	5.1
SMS 60.3/63.5	104	82	15	41	89	104	157	68	230	53	303	360	30	165	112	83	386	3.9	5.9
SMS 72/76	119	82	15	41	89	104	157	76	239	53	312	368	30	165	120	91	395	3.9	6.4
SMS 100/104	149	90	19	45	115	140	174	90	275	53	353	416	35	260	155	112	445	5.1	10.7
DIN 26/28	79	68	15	34	89	104	157	55	218	53	291	347	30	165	100	70	371	1.8	5.1
DIN 32/34	79	68	15	34	89	104	157	55	218	53	291	347	30	165	100	70	371	1.6	5
DIN 38/40	79	70	15	35	89	104	157	55	218	53	291	347	30	165	100	70	371	1.8	4.9
DIN 50/53	89	70	15	35	89	104	157	60	223	53	296	352	30	165	105	75	377	1.8	5.1
DIN 66/70	119	82	15	41	89	104	157	76	239	53	312	368	30	165	120	91	395	3.5	6.2
DIN 81/85	129	82	15	41	89	104	157	76	239	53	317	368	30	165	120	91	395	4.1	6.6
DIN 100/104	149	90	19	45	115	140	174	90	275	53	353	416	35	260	155	112	445	5.1	10.7
DIN 125/129	179	92	19	46	115	140	174	105	291	53	374	431	35	260	170	128	471	7.1	12.5
DIN 150/154	204	92	19	46	115	140	174	118	303	53	386	444	35	260	190	140	487	8.4	13.6
US 1" (22.1/25.4)	79	68	15	34	89	104	157	55	218	53	291	347	30	165	100	70	371	1.8	5.1
US 1" 1/2 (34.8/38.1)	79	70	15	35	89	104	157	55	218	53	291	347	30	165	100	70	371	1.8	4.9
US 2" (47.5/50.8)	89	70	15	35	89	104	157	60	223	53	296	352	30	165	105	75	377	1.8	5.1
US 2" 1/2 (60.2/63.5)	104	82	15	41	89	104	157	68	230	53	303	360	30	165	112	83	386	3.9	5.9
US 3" (72.9/76.1)	119	82	15	41	89	104	157	76	239	53	312	368	30	165	120	91	395	3.9	6.4
US 4" (97.4/101.6)	149	90	19	45	115	140	174	90	275	53	353	416	35	260	155	112	445	5.1	10.7
US 6" (146.9/152.4)	204	92	19	46	115	140	174	118	303	53	386	444	35	260	190	140	487	8.4	13.6

Diaphragm valves DMX - DMAX



FEATURES

- No product entrapment areas that prevents the development of bacteria
- Retained passage diameter
- Low loss of pressure
- Quick assembly and disassembly ; easy maintenance
- Easy to adjust operating devices
- Machined solid body to guarantee good material uniformity
- Valve can be washed and sterilised
- Leak detection in case of deterioration of the diaphragm

SPECIFICATIONS

DIMENSIONS

- Diaphragm valve: DN 9/13.5 to DN 41.8/48.3 ISO STD
- Sampling diaphragm valve: DN 6/8 to DN 16/18 DIN

MATERIALS

- Body: stainless steel 316L
 Handle: plastic material PBT (thermoplastic polymer polyester)
 stainless steel 304 (on request)
 Actuator: stainless steel 304
 Diaphragm: uniform composite diaphragm (PTFE and elastomer) FDA/3A certified
 EPDM or silicon diaphragm

CONNECTIONS

- | CONNECTION TYPES | STANDARDS |
|------------------|-------------------------|
| Welded | SMS - DIN - US standard |
| Threaded | SMS - DIN |
| Liner-nut | SMS - DIN |
| Clamp | US standard |

OPERATING DEVICES

- MANUAL - DMX**
 Ergonomic handle with visual opening indicator
- AUTOMATIC - DMAX**
 Single or double acting valve actuator

SIGNALLING EQUIPMENT

- Visible on single or double stainless steel bracket
 Point to point or AS-i control unit
 ICS (from DN 9 to DN 53)

SURFACE CONDITIONS

- RA exterior = 1.2 µm (150 grit)
- RA interior = 0.8 µm (180 grit)
 0.4 µm (240 grit), on request
 0.2 µm (320 grit), on request

SERVICE CONDITIONS

- Max. temperature: + 140°C
- Min. temperature: 0°C
- Working pressure: 10 bar (1000 kPa) elastomer diaphragm
 8 bar (800 kPa) PTFE diaphragm
- Vacuum resistance elastomer diaphragm: 10⁻⁶ mbar
- Helium tightness (leakage rate): 10⁻⁶ atm.cm³/s
- Vacuum resistance PTFE diaphragm: 10⁻³ mbar
- Helium tightness (leakage rate): 10⁻³ atm.cm³/s
- Actuator air supply pressure: min. 5.5 bar (550 kPa) - max. 8 bar (800 kPa)
- Fatigue resistance: 100 000 cycles elastomer diaphragm
 40 000 cycles PTFE diaphragm

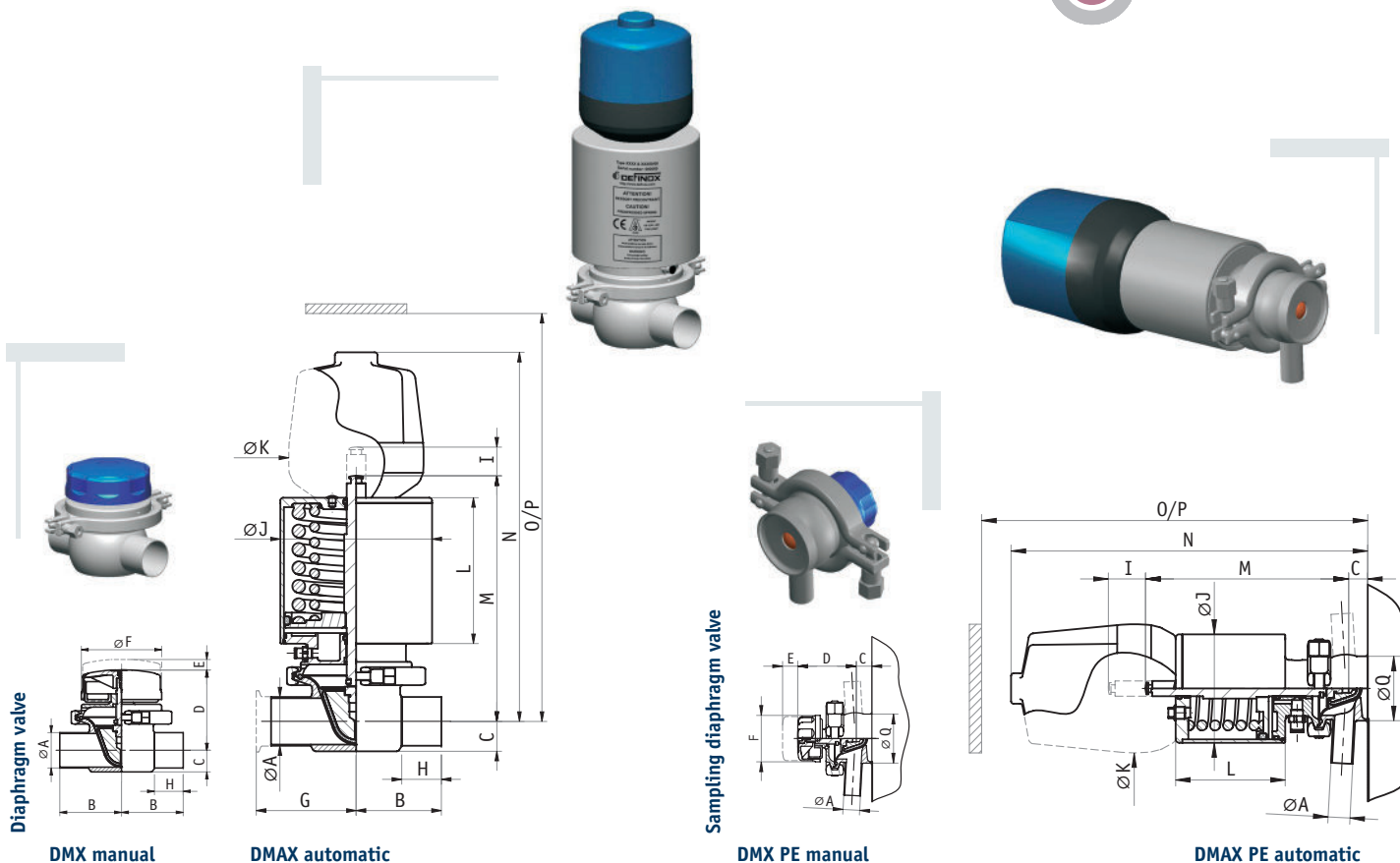

DMX manual

DMAX automatic

DMX PE manual

DMAX PE automatic

Tube ØA	B	C	D	E	ØF	G	H	I	ØJ	ØK	L	M	N	O	P	ØQ	Weight in Kg		
																	DMX	DMAX	
Standard version				(stroke)				(stroke)						(without unit)	(with unit)				
ISO STD 9/13.5	30	13	56	5	50	42.5	18	5	59	104	90	173	268	191	286	-	0.3	2.5	
ISO STD 12.5/17.2	50	15	69	10	50	62.5	29	11	89	104	90	182	280	212	310	-	1	3.2	
ISO STD 16/21.3	50	17	68	10	50	62.5	30	11	89	104	90	181	279	210	308	-	1	3.2	
ISO STD 21.6/26.9	60	22	98	12	78	72.5	26	12	114	104	120	224	315	263	354	-	2.4	7	
ISO STD 27.2/33.7	60	25	95	12	78	72.5	26	12	114	104	120	222	313	257	348	-	2.5	7.2	
ISO STD 35.9/42.4	88.5	29	120	22	78	101	43	22	159	140	147	274	364	327	419	-	4	13.3	
ISO STD 41.8/48.3	88.5	35	117	22	78	101	42	22	159	104	147	271	361	320	413	-	4	13.3	
Sampling																			
DN 6/8	-	5	56	5	50	-	-	5	59	104	90	173	280	193	300	25	0.3	2.5	
DN 10/12	-	8	68	5	50	-	-	5	89	104	90	181	294	201	324	53	0.3	3.5	
DN 9/13.5	-	8	68	5	50	-	-	5	89	104	90	181	294	201	324	53	0.3	3.7	
DN 16/18	-	8	68	10	50	-	-	11	89	104	90	181	294	211	334	53	1	4	

Manual sampling valves PEX - PEAX

FEATURES

- Simple and secure sampling solution
- Flame sterilisation (1 branch PEX1 / PEAX1) or steam injection sterilisation or cleaning with a sterilising agent (2 branches PEX2 / PEAX2)
- Neutral diaphragm available FDA certified
- Quick and easy to change operating devices

SPECIFICATIONS

DIMENSIONS

- DIN: DN 6/8 to DN 16/18

MATERIALS

- Body: stainless steel 316L, machined from solid
 Handle: white plastic material or stainless steel 304
 Actuator: stainless steel 304
 Diaphragm: elastomer (Fluorinated elastomer (FKM)-EPDM or white silicon)

VALVE BODY CONNECTIONS

- Wall welded
- Clamp
- Pipe line welded
- Male gas end

OPERATING DEVICES

- MANUAL - PEX**
 Ergonomic handle
- AUTOMATIC - PEAX**
 Compact pneumatic valve actuator
 Stainless steel operating lever for DN6 and 10 for manual control in an automatic cycle

SIGNALLING EQUIPMENT

- Detection possible, on request

SURFACE CONDITIONS

- RA exterior = 0.8 µm (180 grit)
- RA interior = 0.8 µm (180 grit), standard
 0.4 µm (240 grit), on request

SERVICE CONDITIONS

- Max. temperature: + 120°C
- Min. temperature: 0°C
- Working pressure: 10 bar (1000 kPa)
- Actuator air supply pressure: 4 to 6 bar (400 to 600 kPa)
- Air connection: Ø 4/6

Tube ØB	ØA	ØB	C	ØD	E	F	ØG	H	Standard clamp			Weight in Kg		
									ØI	ØJ	ØK	PEX	PEAX	
DN 6/8	Ø4.5	Ø28	60	Ø26	5	75	Ø33	115	Ø50.4	Ø5.9	Ø7	12	0.2	0.5
DN 10/12	Ø8	Ø36	65	Ø30	7	90	Ø39	140	Ø50.4	Ø9.9	Ø11	12	0.3	0.65
DN 16/18	Ø15	Ø52	85	Ø39	7	102	Ø55	160	Ø50.4	Ø16.9	Ø18	12	0.75	1.5

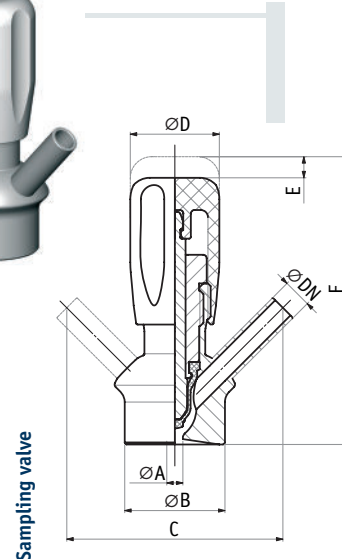

Sampling valve

PEX manual

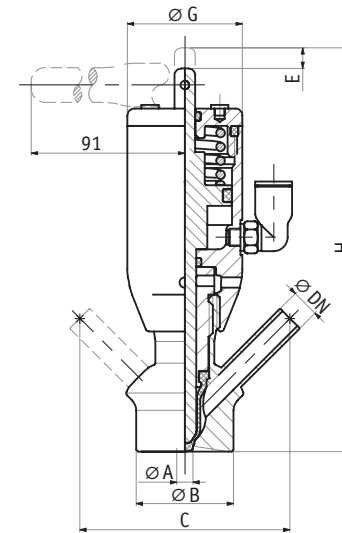

PEAX automatic

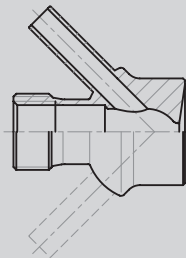
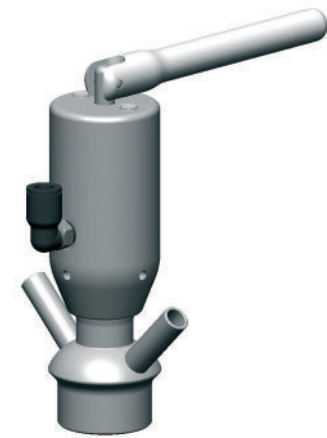

Wall welded

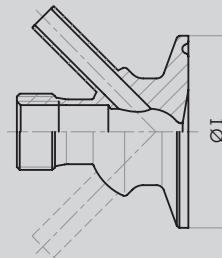

Clamp

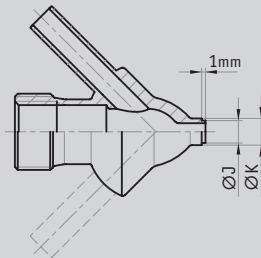

Pipe line welded

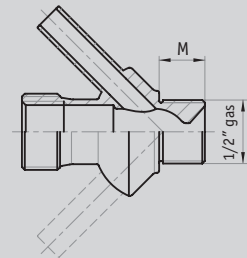

Male gas end

Single sealing changeover valves DCX3 - DCX4

FEATURES

- Fitted as standard with a floating PFA valve seal that can be cleaned and offers outstanding tightness at high temperatures and good resistance to chemical products
- Dismountable pneumatic valve actuator that can be easily transformed into NO (normally open) - NC (normally closed) or DA (double acting)
- Connection of actuators and shut-off units with clamps for easier maintenance and offering a variety of options
- Spherical body with thick walls guaranteeing excellent resistance to expansion constraints and offering a variety of configurations: + - T - L - L/L - T/L

SPECIFICATIONS

DIMENSIONS

- SMS - DIN - US
from DN 25 (1") to DN 104 (4") for the manual version
from DN 25 (1") to DN 150 (6") for the automatic version

MATERIALS

- Body: stainless steel 316L
- Shut-off unit: stainless steel 316L
- Valve seal: floating PFA - EPDM
Fluorinated elastomer (FKM) or silicon
- Other seals: EPDM - Fluorinated elastomer (FKM) or silicon
- Operating devices: stainless steel 304

CONNECTIONS

- | | |
|------------------|-------------------------|
| CONNECTION TYPES | STANDARDS |
| Welded | SMS - DIN - US standard |
| Threaded | SMS - DIN |
| Liner-nut | SMS - DIN |
| Clamp | US standard |

OPTIONS

- Stem sterilisation for an upper bearing
- Elastomer seal tightness
- Deformable sealing diaphragm in PTFE (for aseptic circuits)
- Long stroke for maximum valve disengage
- Deformable sealing diaphragm in PTFE and alcohol barrier

SIGNALLING EQUIPMENT

- Visible on single or double stainless steel bracket
- Point-to-point or AS-i control unit
- ICS (from DN 25 to DN 76)
- ACS (from DN 25 to DN 150)

SURFACE CONDITIONS

- RA exterior = 1.2 µm (150 grit)
- RA interior = 0.8 µm (180 grit)

SERVICE CONDITIONS

- Max. temperature: + 140°C (temperature depending on seal type)
- Min. temperature: -5°C
- Working pressure: 6 bar (600 kPa)
- Sealing pressure: 8 bar (800 kPa)
- Actuator air supply pressure: min. 5.5 bar (550 kPa) - max. 8 bar (800 kPa)
- Vacuum resistance: 0.4 cm³/s

Changeover valve



DCX3 manual

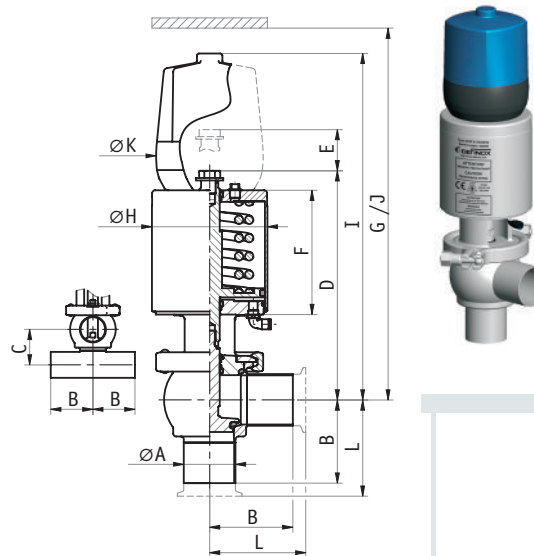

DCX3 automatic

Changeover valve

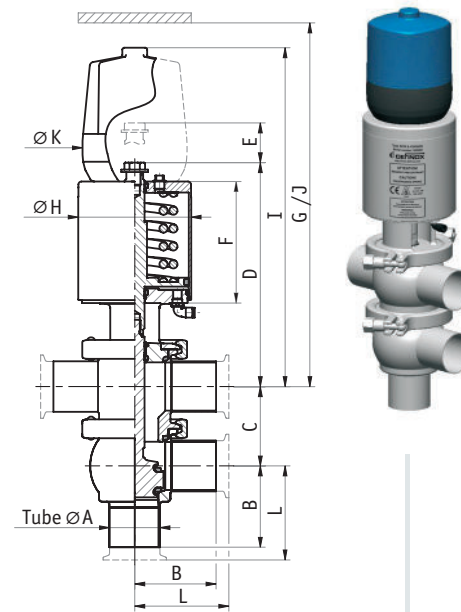

DCX4 automatic

Tube ØA	B		C		D		E (stroke)		F	G	ØH	I	J	ØK	L		Weight in Kg	
	DCX3	DCX4	DCX3	DCX4	DCX3	DCX4	(without unit)	(with unit)							DCX3	DCX4		
SMS 22.6/25	55	45	55	193	192	17	14	110	280	89	302	430	104	70	4.5	6		
SMS 35.6/38	70	55	70	195	195	21	18	110	300	89	309	430	104	85	5	6.5		
SMS 48.5/51	82	70	80	224	225	29	27	123	340	114	338	460	104	97	8	9		
SMS 60.3/63.5	105	85	95	276	275	35	32	159	400	167	388	500	104	125	17	20		
SMS 72/76	110	95	105	281	280	35	32	159	430	167	394	510	104	130	17	21		
SMS 100/104	130	125	150	333	335	40	35	181	530	216	461	600	140	155	33	40		
DIN 26/28	55	47	55	192	192	17	14	110	280	89	302	430	104	-	4.6	5		
DIN 32/34	55	51	65	197	194	17	17	110	300	89	307	430	104	-	4.7	5		
DIN 38/40	70	55	70	195	195	21	18	110	310	89	309	430	104	-	5	5		
DIN 50/53	80	71	80	224	225	29	27	123	340	114	338	460	104	-	8	9		
DIN 66/70	108	93	100	277	277	35	31	159	400	167	390	500	104	-	17	20		
DIN 81/85	115	105	130	288	291	40	36	159	420	167	420	510	104	-	18	23		
DIN 100/104	130	125	150	333	335	40	35	181	530	216	461	600	140	-	33.1	45.8		
DIN 125/129	160	155	165	488	488	70	56	285	590	270	614	730	140	-	62	73		
DIN 150/154	180	180	195	500	500	70	62	285	620	270	625	760	140	-	65	78		
US 1" (22.1/25.4)	51	45	82.5	192	192	17	14	110	280	89	302	430	104	64	4.5	6		
US 1 1/2 (34.8/38.1)	57	55	82.5	195	195	21	18	110	300	89	309	430	104	70	5	6.5		
US 2" (47.5/50.8)	76	70	95	224	225	29	27	123	350	114	338	470	104	89	7.5	10.2		
US 2 1/2 (60.2/63.5)	76	85	108	276	275	35	32	159	420	167	388	520	104	89	15	19.3		
US 3" (72.9/76.1)	82	95	120	281	280	35	32	159	430	167	394	520	104	95	15.5	19.1		
US 4" (97.4/101.6)	130	125	165	333	335	40	35	181	540	216	461	590	140	146	33	40		
US 6" (146.9/152.4)	180	180	195	500	500	70	62	285	620	270	625	760	140	200	65	78		

Fractional changeover valves DCX3 - DCX4

FEATURES

- High sealing pressure
- Self-contained and compact body with a variety of configuration options: + - T - L - L/L - T/L
- Quick to disassemble

SPECIFICATIONS

DIMENSIONS

- US DN 1/2" - 3/4"

MATERIALS

- Body: stainless steel 316L
- Shut-off unit: stainless steel 316L
- Valve seal: PFA - EPDM - Fluorinated elastomer (FKM) or silicon
- Handle: plastic material
- Actuator: stainless steel 304

CONNECTIONS

- To weld
- Clamp

OPERATING DEVICES

MANUAL

Ergonomic handle with visual opening indicator

AUTOMATIC

Single or double-acting compact pneumatic valve actuator

SIGNALLING EQUIPMENT

Visible on single or double stainless steel bracket
Point-to-point or AS-i control unit
ICS (DN 1/2" - DN 3/4")

SURFACE CONDITIONS

- RA exterior = 1.2 µm (150 grit)
- RA interior = 0.8 µm (180 grit)

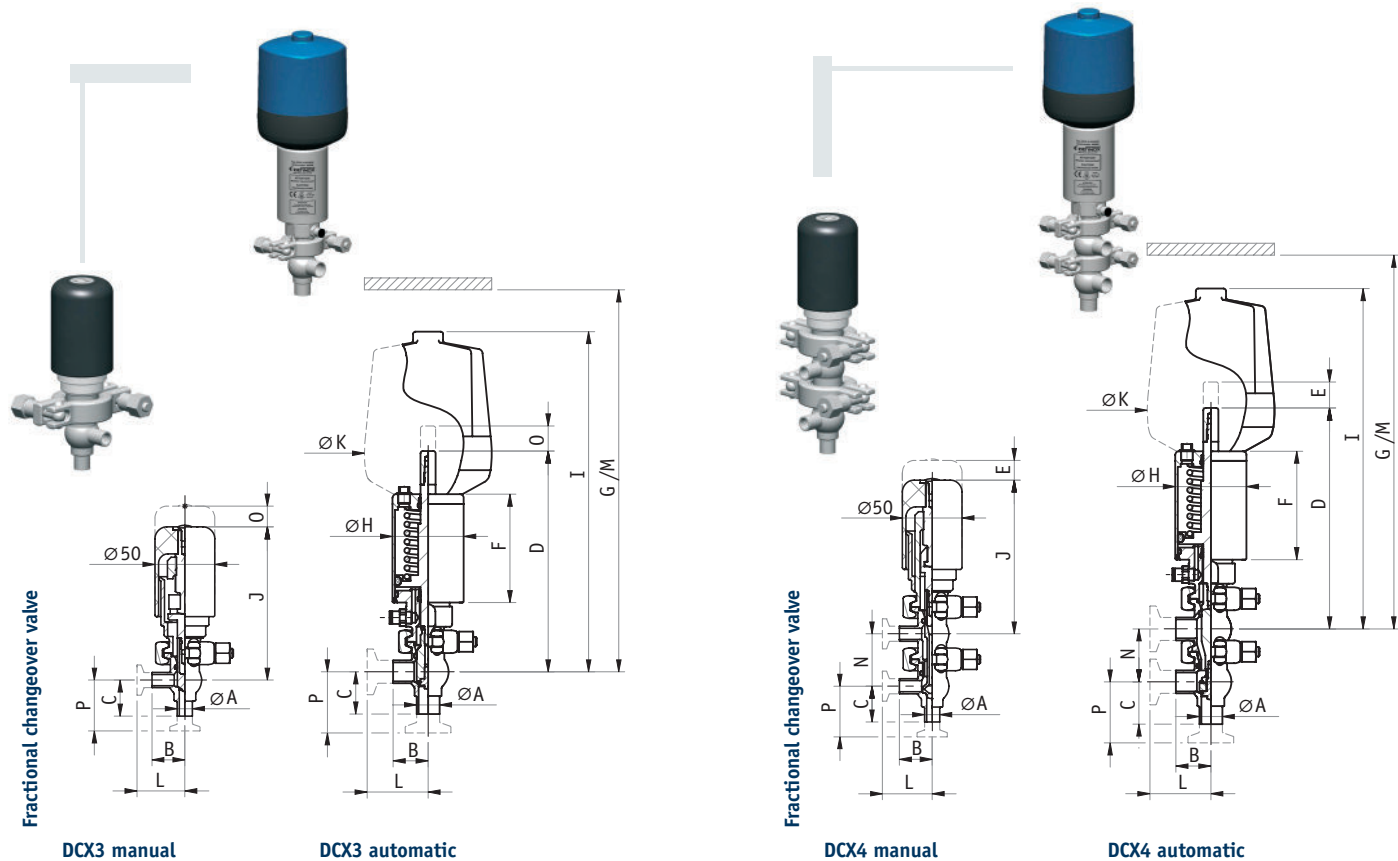

Tube ØA	B	C	D	E	F	G	ØH	I	J	ØK	L	M	N	O	P	Weight in Kg DCX3		Weight in Kg DCX4	
																MANUAL	AUTO	MANUAL	AUTO
US 1/2" (9.4/12.7)	27.5	30	192	10.5	90	215	59	277	128	104	40	300	44	12	42.5	0.6	1.5	0.7	1.6
US 3/4" (15.75/19.05)	29	35	195	11	90	220	59	279	130	104	41.5	304	44	12	47.5	0.6	1.5	0.7	1.7
US 1" (22.1/25.4)	35.3	40	212	14.7	103	240	71	294	130	104	64	322	55	15	64	1	1.9	1.1	2

SERVICE CONDITIONS

- Max. temperature: + 140°C (temperature depending on seal type)
- Min. temperature: -5°C
- Working pressure: 16 bar (1600 kPa)
- Sealing pressure: 18 bar (1800 kPa)
- Actuator air supply pressure: min. 5.5 bar (550 kPa) - max. 8 bar (800 kPa)
- Vacuum resistance: 0.4 cm³/s

Double sealing changeover valve DCX3 DE

FEATURES

- Non-independent double valve system
- Leakage chamber with indicator preventing any risk of mixing between the lines
- Able to absorb overpressure under the plug
- Spherical body with thick walls guaranteeing excellent resistance to expansion constraints

SPECIFICATIONS

DIMENSIONS

- SMS - DIN - US
from DN 51 (2") to DN 100 (4")

MATERIALS

- Body: stainless steel 316L
- Shut-off unit: stainless steel 316L
- Valve seal: EPDM - Fluorinated elastomer (FKM) or silicon
- Actuator: stainless steel 304

CONNECTIONS

- | | |
|------------------|-------------------------|
| CONNECTION TYPES | STANDARDS |
| To weld | SMS - DIN - US standard |
| Threaded | SMS - DIN |
| Liner-nut | SMS - DIN |
| Clamp | US standard |

OPTIONS

Washing micro-valve that cleans the leakage chamber and the leakage micro-valve when the valve is closed (requiring a 2nd solenoid valve in the control unit)

SIGNALLING EQUIPMENT

Visible on single or double stainless steel bracket
Point-to-point or AS-i control unit
ICS (from DN 51 to DN 76)
ACS (from DN 51 to DN 104)

SURFACE CONDITIONS

- RA exterior = 1.2 µm (150 grit)
- RA interior = 0.8 µm (180 grit)

SERVICE CONDITIONS

- Max. temperature: + 120°C
- Min. temperature: 0°C
- Working pressure: 7 bar (700 kPa)
- Sealing pressure: 8 bar (800 kPa)
- Actuator air supply pressure: min. 5.5 bar (550 kPa) - max. 8 bar (800 kPa)
- Vacuum resistance: 0.3 cm³/s

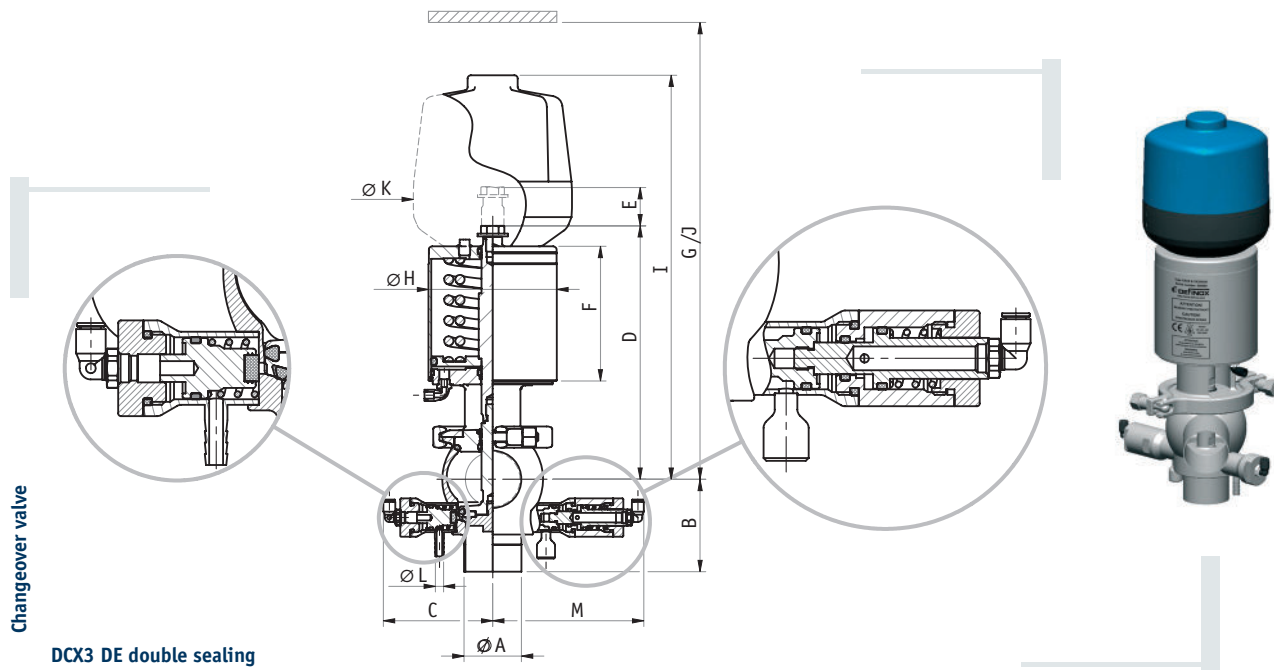

Changeover valve

DCX3 DE double sealing

Tube ØA	B	C	D	E (stroke)	F	G (without unit)	ØH	I	J (with unit)	ØK	ØL	M	Weight in kg
SMS 48.5/51	82	97	227	29	123	360	114	342	470	104	8	134	8
SMS 60.3/63.5	105	107	276	35	159	430	167	390	510	104	8	144	17
SMS 72/76	110	113	282	35	159	460	167	397	530	104	8	152	17.5
SMS 100/104	130	127	338	40	181	550	216	463	600	140	8	166	36.5
DIN 50/53	80	97	227	29	123	360	114	342	470	104	8	134	8
DIN 66/70	108	113	279	35	159	460	167	393	530	104	8	152	17.5
DIN 81/85	115	127	288	40	159	470	167	404	540	104	8	166	18
DIN 100/104	130	127	338	40	181	550	216	463	600	140	8	166	37
US 2" (47.5/50.8)	76	97	227	29	123	370	114	342	470	104	8	134	8
US 2"1/2 (60.2/63.5)	76	107	276	35	159	430	167	390	510	104	8	144	17
US 3" (72.9/76.1)	82	113	282	35	159	460	167	397	530	104	8	152	17.5
US 4" (97.4/101.6)	130	127	338	40	181	550	216	463	600	140	8	166	36.5

Single sealing changeover valve DCX3 options

DCX3 relief valve

FEATURES

- A predefined pressure enables the main circuit to be off-loaded thus protecting certain equipment or circuits
- Actuator with special spring
- Option to add additional air via a unit with a single regulator

SPECIFICATIONS

DIMENSIONS

- SMS - DIN - US from DN 25 (1") to DN 100 (4")

SERVICE CONDITIONS

- Max. temperature: + 140°C
- Min. temperature: -5°C
- Max. loading pressure: 12 bar (1200 kPa)
- Sealing pressure: 13 bar (1300 kPa)
- Actuator air supply pressure: min. 5.5 bar (550 kPa) - max. 8 bar (800 kPa)
- Vacuum resistance: 0.4 cm³/s

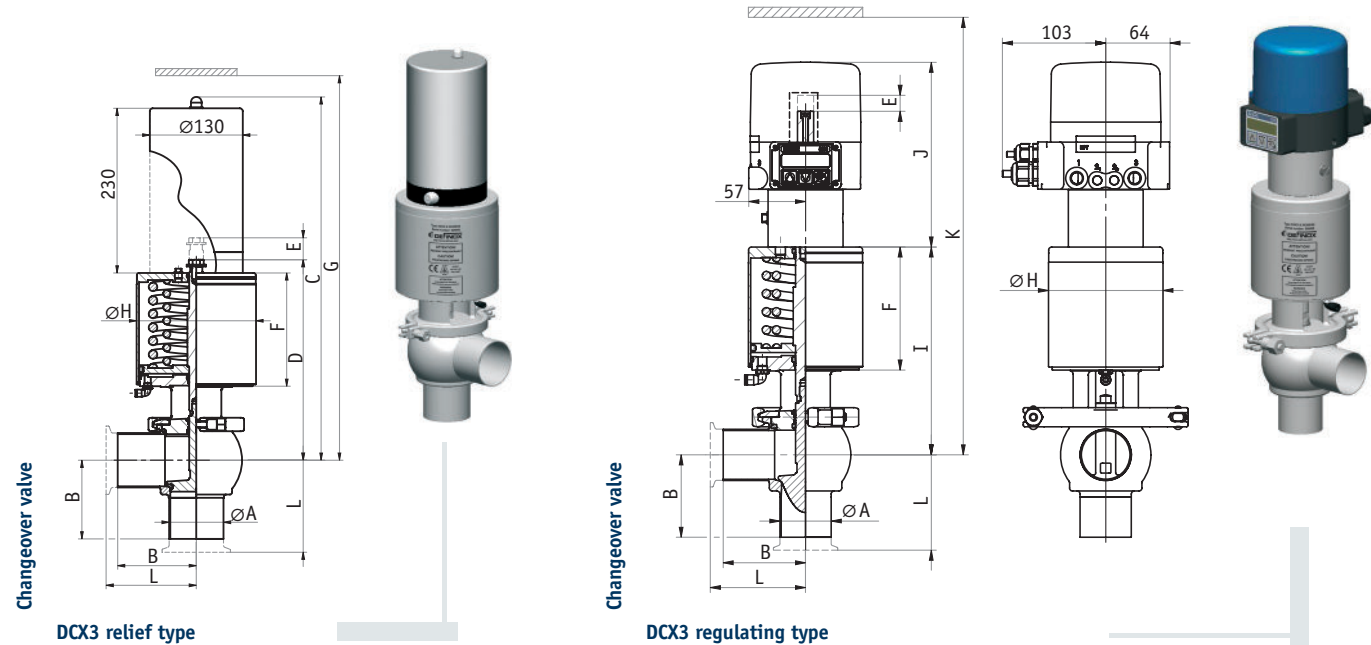

DCX3 Regulating Valve

FEATURES

- Fitted with a positioner enabling the flow, pressure or level to be regulated on all supply fluids using a signal (0)4/20 mA or 0/10 V.
- Profiled plug (without sealing)

SPECIFICATIONS

DIMENSIONS

- SMS - DIN - US from DN 25 (1") to DN 100 (4")

OPTIONS

Elastomer seal for absolute tightness

SERVICE CONDITIONS

- Max. temperature: + 140°C
- Min. temperature: -5°C
- Working pressure: 6 bar (600 kPa)
- Sealing pressure: 8 bar (800 kPa), with elastomer seal
- Actuator air supply pressure: min. 5.5 bar (550 kPa) - max. 8 bar (800 kPa)
- Vacuum resistance: 0.7 cm³/s

DIMENSIONS Tube ØA	(STANDARD)					RELIEF VALVE				REGULATING VALVE			
	B	E (stroke)	F	ØH	L	C	D	G (with unit)	Weight in kg	I	J	K (with unit)	Weight in kg
SMS 22.6/25	55	17	110	89	70	415	193	490	4	170	165	390	5.5
SMS 35.6/38	70	21	110	89	85	422	195	490	4	177	165	400	5.5
SMS 48.5/51	82	29	123	114	97	451	224	520	7	206	185	500	8.5
SMS 60.3/63.5	105	35	159	167	125	501	276	590	16	256	185	560	17.5
SMS 72/76	110	35	159	167	130	507	281	600	16	262	185	590	17.5
SMS 100/104	130	40	181	216	155	557	333	750	28	312	185	660	29.5
DIN 26/28	55	17	110	89	-	415	192	490	4	170	165	390	5.5
DIN 32/34	55	17	110	89	-	420	197	490	4	175	165	400	5.5
DIN 38/40	70	21	110	89	-	422	195	490	4	177	165	400	5.5
DIN 50/53	80	29	123	114	-	451	224	520	7	206	185	500	8.5
DIN 66/70	108	35	159	167	-	503	277	590	16	258	185	570	17.5
DIN 81/85	115	40	159	167	-	548	288	610	27	268	185	580	20.5
DIN 100/104	130	40	181	216	-	557	333	750	28	312	185	660	29.5
US 1" (22.1/25.4)	51	17	110	89	64	415	192	490	4	170	165	390	5.5
US 1 1/2 (34.8/38.1)	57	21	110	89	70	422	195	500	4	177	165	400	5.5
US 2" (47.5/50.8)	76	29	123	114	89	451	224	520	7	206	185	500	8.5
US 2 1/2 (60.2/63.5)	76	35	159	167	89	501	276	590	16	256	185	560	17.5
US 3" (72.9/76.1)	82	35	159	167	95	507	281	600	16	262	185	590	17.5
US 4" (97.4/101.6)	130	40	181	216	146	557	333	750	28	312	185	660	29.5

Tank bottom changeover valves DCX3 Fdc



FEATURES

- Body and plug shape provide the tightest seal to the tank wall, without retention area
- Same features as standard DCX3 (floating seal - thick body, etc...)
- Two versions: Raising or Lowering plug

SPECIFICATIONS

DIMENSIONS

- SMS - DIN - US from DN 25 (1") to DN 100 (4")

MATERIALS

- Body: stainless steel 316L
- Shut-off unit: stainless steel 316L
- Flange: stainless steel 316L
- Plug seal: PFA
- Body seal: EPDM - Fluorinated elastomer (FKM) or silicon
- Actuator: stainless steel 304

CONNECTIONS

- On tank with special welded flange

OPTIONS

- Long stroke actuator for complete disengage of the plug (recommended for fragile or inconsistent products)

SIGNALLING EQUIPMENT

- Visible on single or double stainless steel bracket
- Point-to-point or AS-i control unit
- ICS (from DN 25 to DN 76)
- ACS (from DN 25 to DN 104)

SURFACE CONDITIONS

- RA exterior = 1.2 µm (150 grit)
- RA interior = 0.8 µm (180 grit)

SERVICE CONDITIONS

- Max. temperature: + 140°C
- Min. temperature: -5°C
- Working pressure: 6 bar (600 kPa)
- Sealing pressure: 7 bar (700 kPa)
- Actuator air supply pressure: min. 5.5 bar (550 kPa) - max. 8 bar (800 kPa)
- Vacuum resistance: 0.4 cm³/s

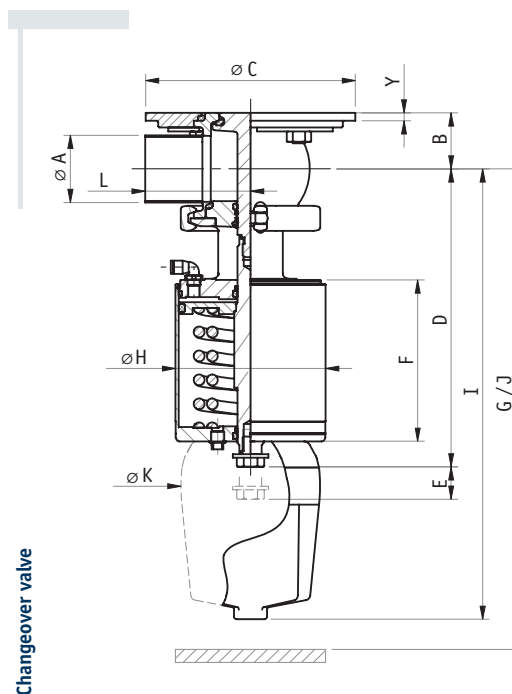

Changeover valve

DCX3 Tank Bottom Valve-Lowering plug

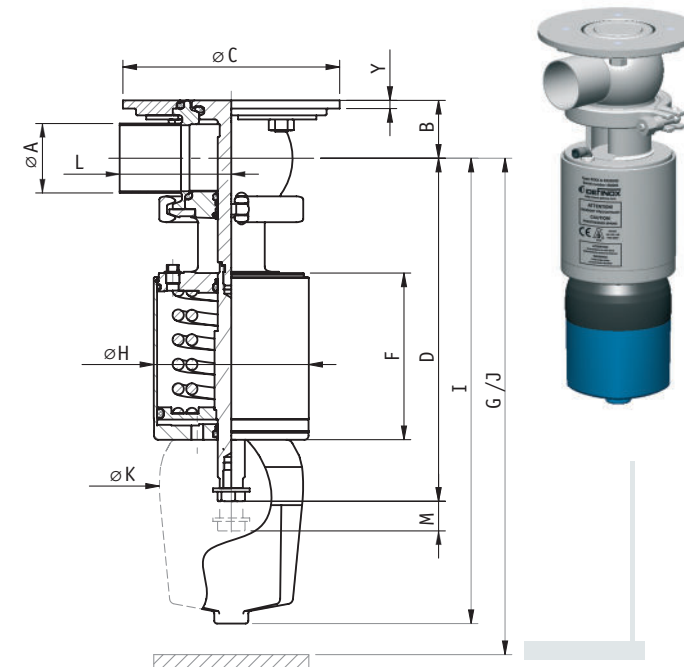

DCX3 Tank Bottom Valve-Raising Plug



Tube ØA	B	ØC	D	E	F	G	ØH	I	J	ØK	L	M	Weight
				(lowering plug stroke)		(without unit)			(with unit)			(raising plug stroke)	in kg
SMS 22.6/25	29.5	139	189	23.5	109.5	300	89	320	450	104	55	21	4.5
SMS 35.6/38	35	139	193.5	25.5	109.5	320	89	327	450	104	70	21	5
SMS 48.5/51	42.5	159	226	29.5	123	360	114	356	470	104	82	19.5	8.5
SMS 60.3/63.5	48.5	189	275.5	35	159	420	167	406	520	104	105	20.5	15
SMS 72/76	55	189	282	35	159	450	167	412	530	104	110	20	15.4
SMS 100/104	75	249	337	40	181	600	216	462	700	140	130	20	47
DIN 26/28	30.5	139	191.5	22.5	109.5	300	89	320	450	104	55	20.5	4.5
DIN 32/34	33.5	139	192	25.5	109.5	300	89	325	450	104	55	28	4.7
DIN 38/40	36	139	194	26	109.5	300	89	327	450	104	70	28	5.2
DIN 50/53	42.5	159	226	29.5	123	360	114	356	470	104	80	28	8.4
DIN 66/70	52	189	279	34.5	159	460	167	408	530	104	108	35	15
DIN 81/85	65	249	288	39.5	159	470	167	419	540	104	115	35	29
DIN 100/104	75	249	337	40	181	600	216	462	700	140	130	34.5	47
US 1" (22.1/25.4)	29.5	139	189	23.5	109.5	300	89	320	450	104	51	35	4.5
US 1 1/2 (34.8/38.1)	35	139	193.5	25.5	109.5	320	89	327	450	104	57	35	5
US 2" (47.5/50.8)	42.5	159	226	29.5	123	360	114	356	470	104	76	39.5	8.5
US 2 1/2 (60.2/63.5)	48.5	189	275.5	35	159	420	167	406	520	104	76	39.5	15
US 3" (72.9/76.1)	55	189	282	35	159	450	167	412	530	104	82	39.5	15.4
US 4" (97.4/101.6)	75	249	337	40	181	600	216	462	700	140	130	39.5	47

Tank bottom mixproof valve VDCI FdC

FEATURES

- Isolates the tank from the rest of the process circuit
- Body and plug shape provide the tightest seal to the tank wall, without retention area
- Same features as VDCI MC (floating seal - thick body, etc...)
- Leakage chamber washed by pulsing the lower plug

SPECIFICATIONS

DIMENSIONS

- SMS - DIN - US
from DN 51 (2") to DN 100 (4")

MATERIALS

- Body: stainless steel 316L
- Shut-off unit: stainless steel 316L
- Plug seal: PFA
- Other seals: EPDM - Fluorinated elastomer (FKM)
- Actuator: stainless steel 304

CONNECTIONS

- On tank with special welded flange

OPTIONS

- Steam bearing stem

SIGNALLING EQUIPMENT

- Lantern detection and cabinet control solenoid valves

SURFACE CONDITIONS

- RA exterior = 1.2 µm (150 grit)
- RA interior = 0.8 µm (180 grit)

SERVICE CONDITIONS

- Max. temperature: + 140°C
- Temperature differential between the upper line and the lower line: max. 90°C
- Min. temperature: -5°C
- Working pressure in the tank: 4 bar (400 kPa)
- Working pressure: 6 bar (600 kPa)
- Sealing pressure: 7 bar (700 kPa)
- Actuator air supply pressure: min. 5.5 bar (550 kPa) - max. 8 bar (800 kPa)
- Vacuum resistance: 0.4 cm³/s

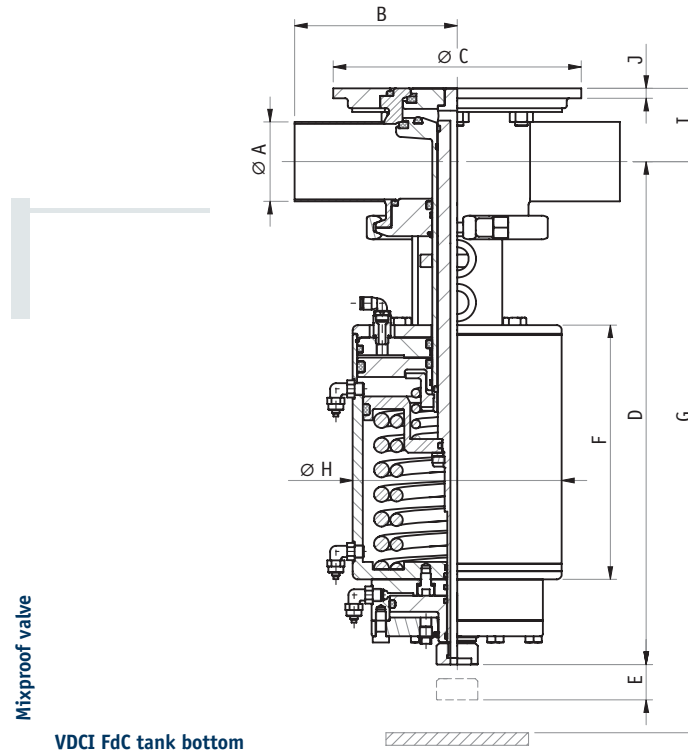

Tube ØA	B	ØC	D	E (stroke)	F	G	ØH	I	J	Weight in kg
SMS 48.5/51	105	178	363	34	179	465	128	49	8	20
SMS 60.3/63.5	130	198	406	40	204	520	167	58	8	35
SMS 72/76	130	198	413	40	204	540	167	64	8	40
SMS 100/104	155	268	471	49	234	635	218	78	10	75
DIN 50/53	105	178	363	34	179	465	128	49	8	20
DIN 66/70	130	198	408	40	204	530	167	61	8	40
DIN 81/85	155	268	461	49	234	625	218	68	10	66
DIN 100/104	155	268	471	49	234	635	218	78	10	75
US 2" (47.5/50.8)	105	178	363	34	179	465	128	49	8	20
US 2 1/2 (60.2/63.5)	130	198	406	40	204	520	167	58	8	35
US 3" (72.9/76.1)	130	198	413	40	204	540	167	64	8	40
US 4" (97.4/101.6)	155	268	471	49	234	635	218	78	10	75

Mixproof valve VDCI MC PFA

FEATURES

- Standard solid machined compact actuator for all versions
- Reduced disassembly and assembly times for the actuator
- Plugs can be removed from the lantern making maintenance much easier
- Volume machined body with a new profile guaranteeing excellent resistance against mechanical and thermal damage
- Counter Balance offering good resistance against pressure hammer
- Improved cleaning of the leakage chamber thanks to the internal plug which has floating seals for easy cleaning and are extremely resistant to chemical attack
- Leak indicator showing any fault in the sealing point between the plugs
- High level of modularity for all options and versions
- Option to accurately detect the movement of each independent plug with our new generation ACS control unit

SPECIFICATIONS

DIMENSIONS

- SMS - DIN - US from DN 38 (1" 1/2) to DN 125 (5")

MATERIALS

- Body: stainless steel 316L
 Shut-off unit: stainless steel 316L
 Plug seal: PFA
 Other seals: EPDM - Fluorinated elastomer (FKM)
 Actuator: stainless steel 304

CONNECTIONS

- | CONNECTION TYPES | STANDARDS |
|------------------|-------------------------|
| Welded | SMS - DIN - US standard |
| Threaded | SMS - DIN |
| Liner-nut | SMS - DIN |
| Clamp | US standard |

OPTIONS

Sterilisation of the stem and counter balancer by the upper and lower bearings

SIGNALLING EQUIPMENT

Visible on double stainless steel bracket
 Point-to-point or AS-i control unit
 ACS (from DN 25 to DN 125)
 Option: Lantern detector for breakaway of the upper plug

SURFACE CONDITIONS

- RA exterior = 1.2 µm (150 grit)
- Interior RA = 0.8 µm (180 grit)

SERVICE CONDITIONS

- Operating temperature: - 5 to 130°C
- Sterilisation temperature: 140°C
- Working pressure: 9 bar (900 kPa)
- Cleaning pressure: 7 bar (700 kPa)
- Actuator air supply pressure: 5 to 7 bar (500 to 700 kPa) with the ACS unit up to 8 bar (800 kPa) with direct supply

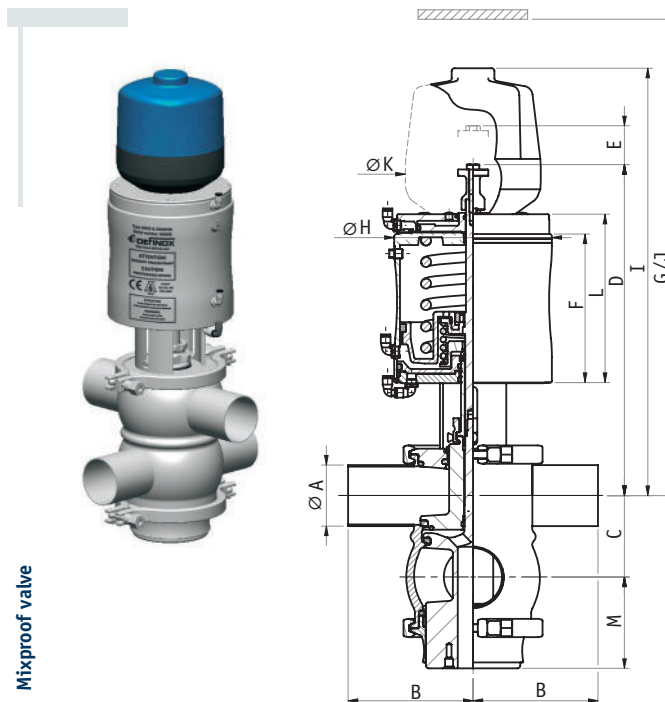

VDCI MC PFA

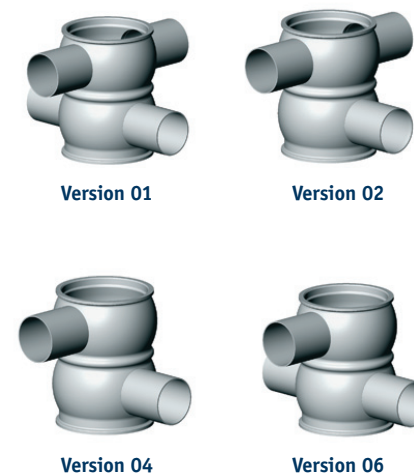

Main body configurations

Tube ØA	B	C	D	E (stroke)	F	G (without unit)	ØH	I	J (with unit)	ØK	L	M	Weight in kg
SMS 35.6/38	105	55	279	26	126	329	128	379	429	140	145	80	14.5
SMS 48.5/51	105	70	287	35	126	377	128	387	477	140	145	88	15
SMS 60.3/63.5	130	85	333	45	156	477	164	433	577	140	175	103	28.5
SMS 72/76	130	95	340	45	156	488	164	440	588	140	175	110	30
SMS 100/104	155	125	418	62	196	645	218	518	745	140	215	141	61.5
DIN 38/40	105	60	280	26	126	330	128	380	430	140	145	81	14.5
DIN 50/53	105	70	287	35	126	377	128	387	477	140	145	88	15
DIN 66/70	130	90	337	45	156	473	164	437	573	140	175	106	29
DIN 81/85	155	110	344	45	156	514	164	444	614	140	175	113	31
DIN 100/104	155	125	418	62	196	645	218	518	745	140	215	141	62
DIN 125/129	200	155	431	62	196	712	218	531	812	140	215	152	67
US 1"1/2 (34.8/38.1)	105	55	280	26	126	330	128	380	430	140	145	80	14.5
US 2" (47.5/50.8)	105	70	287	35	126	377	128	387	477	140	145	88	15
US 2"1/2 (60.2/63.5)	130	85	333	45	156	477	164	433	577	140	175	103	28.5
US 3" (72.9/76.1)	130	95	340	45	156	488	164	440	588	140	175	110	30
US 4" (97.4/101.6)	155	125	418	62	196	645	218	518	745	140	215	141	62

Other configurations available on request

FEATURES

- Versions based on the same model as VDCI MC PFA
- **VDCI MC SP** leak-free opening: Sliding plug seal guaranteeing complete tightness and avoiding product loss on opening
- **VDCI MC PMO** Pasteurized Milk Ordinance: leakage section identical to that used in the tubular process

SPECIFICATIONS

DIMENSIONS

- SMS - DIN - US
from DN 38 (1" 1/2) to DN 125 (5")

MATERIALS

- Body: stainless steel 316L
 Shut-off unit: stainless steel 316L
 Plug seal: PFA
 Other seals: EPDM - Fluorinated elastomer (FKM)
 Actuator: stainless steel 304

CONNECTIONS

- CONNECTION TYPES STANDARDS
 To weld SMS - DIN - US standard
 Threaded SMS - DIN
 Liner-nut SMS - DIN
 Clamp US standard

OPTIONS

Sterilisation of the stem and counter balancer by the upper and lower bearings

SIGNALLING EQUIPMENT

Visible on single or double stainless steel bracket
 Point-to-point or AS-i control unit
ACS (from DN 25 to DN 125)
 Option: Lantern detector for breakaway of the upper plug

SURFACE CONDITIONS

- RA exterior = 1.2 µm (150 grit)
- RA interior = 0.8 µm (180 grit)

SERVICE CONDITIONS

- Operating temperature: - 5 to 120°C
- Sterilisation temperature: 130°C
- Working pressure: 9 bar (900 kPa)
- Cleaning pressure: 7 bar (700 kPa)
- Actuator air supply pressure: 5 to 7 bar (500 to 700 kPa) with the ACS unit up to 8 bar (800 kPa) with direct supply

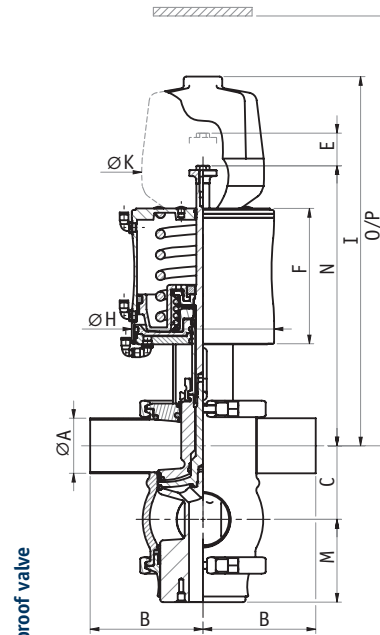

Mixproof valve

VDCI MC SP

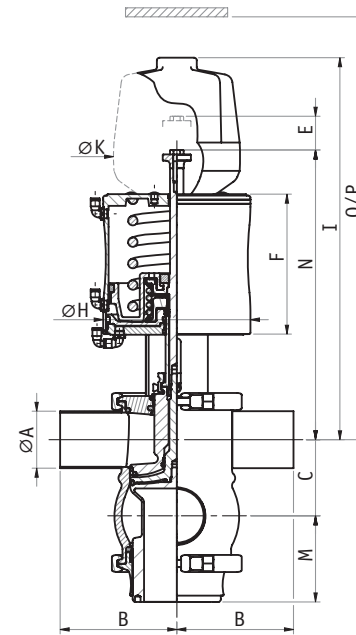

Mixproof valve

VDCI MC PMO



Tube ØA	B	C	D	E (stroke)	F	G (without unit)	ØH	I	J (with unit)	ØK	L	M	N	O (without unit)	P (with unit)	Weight in Kg	
																SP	PMO
SMS 35.6/38	105	55	279	26	126	329	128	379	429	140	145	80	275	325	425	13	-
SMS 48.5/51	105	70	287	35	126	377	128	387	477	140	145	88	282	372	472	13.5	-
SMS 60.3/63.5	130	85	333	45	156	477	164	433	577	140	175	103	323	449	549	25.5	-
SMS 72/76	130	95	340	45	156	488	164	440	588	140	175	110	588	480	580	27.5	-
SMS 100/104	155	125	418	62	196	645	218	518	745	140	215	141	408	635	735	59	-
DIN 38/40	105	60	280	26	126	330	128	380	430	140	145	81	276	333	433	13	-
DIN 50/53	105	70	287	35	126	377	128	387	477	140	145	88	283	373	473	13.5	-
DIN 66/70	130	90	337	45	156	473	164	437	573	140	175	106	326	463	563	26.5	-
DIN 81/85	155	110	344	45	156	514	164	444	614	140	175	113	333	505	605	28	-
DIN 100/104	155	125	418	62	196	645	218	518	745	140	215	141	408	635	735	59	-
DIN 125/129	200	155	431	62	196	712	218	531	812	140	215	152	421	703	803	63	-
US 1"1/2 (34.8/38.1)	105	55	280	26	126	330	128	380	430	140	145	80	275	325	425	13	12.5
US 2" (47.5/50.8)	105	70	287	35	126	377	128	387	477	140	145	88	282	372	472	13.5	13
US 2"1/2 (60.2/63.5)	130	85	333	45	156	477	164	433	577	140	175	103	323	449	549	26	24
US 3" (72.9/76.1)	130	95	340	45	156	488	164	440	588	140	175	110	330	480	580	27.5	24.5
US 4" (97.4/101.6)	155	125	418	62	196	645	218	518	745	140	215	141	408	635	735	59	53.5

NON-RETURN VALVE

- Non-return valve with full bore
- Quick disassembly using an SMS type nut

SPECIFICATIONS

DIMENSIONS

- SMS - DIN - US
from DN 1/2" to DN 125 (5")

MATERIALS

- Body - plug - spring: stainless steel 316L
- Plug seal: PFA
- Seal: Fluorinated elastomer (FKM) - EPDM - PFA

CONNECTIONS

- TYPES OF CONNECTION (STANDARD)
- Welded SMS - DIN - US standard
- Threaded SMS - DIN
- Liner-nut SMS - DIN
- Clamp US standard

OPTIONS

- Metal/metal tightness (requires pairing)

SERVICE CONDITIONS

- Max. temperature: +120°C
- Min. temperature: 0°C
- Working pressure: 10 bar (1000 kPa)
- Counterpressure: 90 mbar

PRESSURE VACUUM VALVE

- Manual forced opening device for 4" version

SPECIFICATIONS

DIMENSIONS

- CLAMP DN 2" and 2"1/2
- CLAMP DN 4"

MATERIALS

- Valve: stainless steel 316L
- Pressure plug: PTFE
- Seal: Fluorinated elastomer (FKM) - silicon

CONNECTIONS

- Clamp

SERVICE CONDITIONS

- Max. temperature: +80°C
- Min. temperature: 0°C
- Vacuum: 30 mbar
- Pressure: 0.2 to 2 bar depending on spring

PRESSURE RELIEF VALVE

- Easy disassembly using an SMS type nut
- Sealing option for a pre-established setting

SPECIFICATIONS

DIMENSIONS

- DN 1" 1/2 - 2"

MATERIALS

- Body and plug: stainless steel 316L
- Seal: Fluorinated elastomer (FKM) - EPDM
- Adjusting device: stainless steel 304

CONNECTIONS

- Welded SMS - DIN - US standard

SERVICE CONDITIONS

- Max. temperature: +120°C
- Min. temperature: 0°C
- Adjustment range: from 0 to 13 bar (1300 kPa)

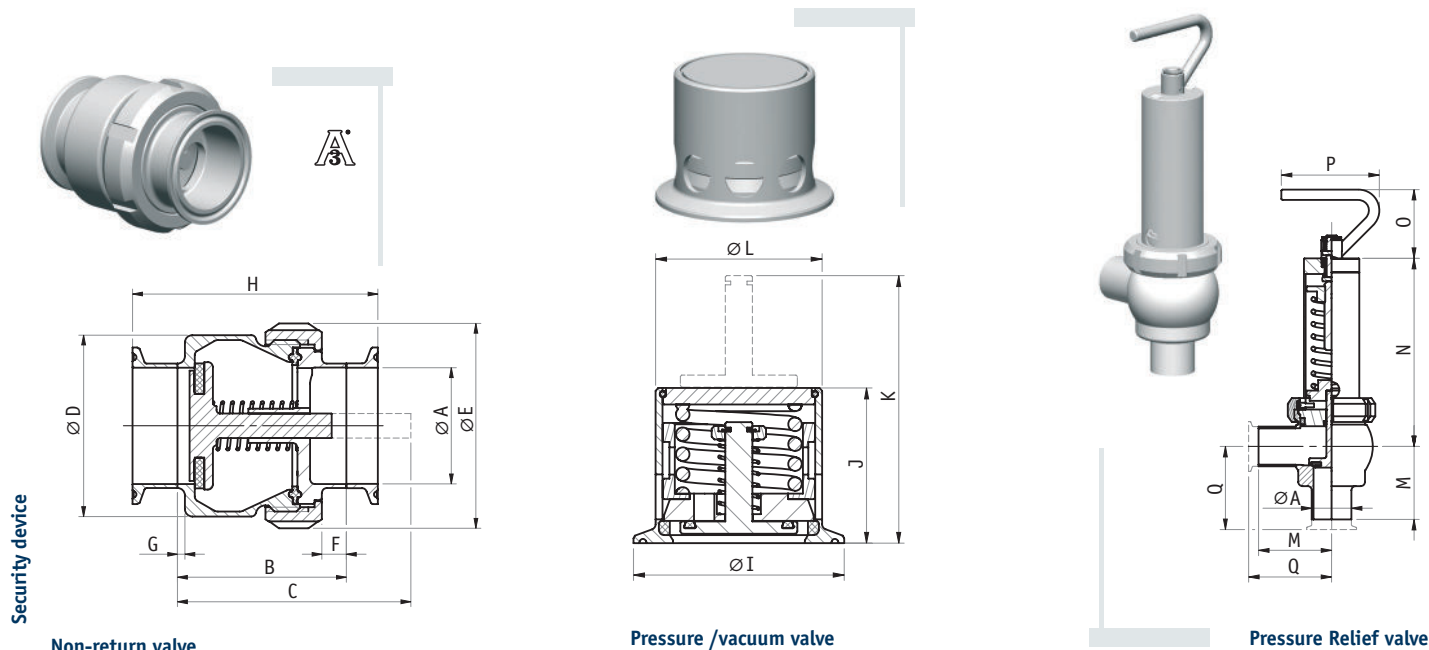

TUBE ØA	NON-RETURN VALVE							Weight in kg
	B	C (release)	ØD	ØE	F	G	H	
SMS 22.6/25	74.5	107	59.5	70	13	9	100.5	0.65
SMS 30/32	70.5	107	59.5	70	9	9	96.5	0.55
SMS 35.6/38	70.5	107	59.5	70	9	9	96.5	0.82
SMS 48.5/51	74.5	115	74	84	10	9	100.5	1.1
SMS 60.3/63.5	108.5	158	110	114	14	10	134.5	2.66
SMS 72/76	104.5	158	110	114	10	10	130.5	2.31
SMS 100/104	123.5	201	148	148	11	11	154.5	4.4
DIN 26/28	74.5	107	59.5	70	13	9	100.5	0.6
DIN 38/40	65.5	102	59.5	70	9	9	91.5	1
DIN 50/53	74.5	115	74	84	10	9	100.5	1.05
DIN 66/70	104.5	158	110	114	10	10	130.5	2.63
DIN 81/85	127.5	201	148	148	15	11	153.5	3.82
DIN 100/104	123.5	201	148	148	11	11	154.5	4.4
DIN 125/129	141.5	229	178	178	9	11	172.5	5.6
US 1/2" (9.4/12.7)	48.5	71	40	49.5	6	5	74.5	0.3
US 3/4" (15.75/19.05)	48.5	71	40	49.5	6	5	74.5	0.3
US 1" (22.1/25.4)	74.5	107	59.5	70	13	9	100.5	0.65
US 1 1/2 (34.8/38.1)	70.5	107	59.5	70	9	9	96.5	0.82
US 2" (47.5/50.8)	74.5	115	74	84	10	9	100.5	1.1
US 2 1/2 (60.2/63.5)	108.5	158	110	114	14	10	134.5	2.66
US 3" (72.9/76.1)	104.5	158	110	114	10	10	130.5	2.31
US 4" (97.4/101.6)	123.5	201	148	148	11	11	154.5	4.43

PRESSURE/VACUUM VALVE				
ØI	J	K	ØL	Weight in kg
-	-	-	-	-
-	-	-	-	-
-	-	-	-	-
-	-	-	-	-
-	-	-	-	-
-	-	-	-	-
-	-	-	-	-
-	-	-	-	-
-	-	-	-	-
68	57	106	61	0.75
-	-	-	-	-
-	-	-	-	-
-	-	-	-	-
-	-	-	-	-
-	-	-	-	-
-	-	-	-	-
64	70	112	61	0.6
77.5	57	99	61	0.55
-	-	-	-	-
-	-	-	-	-
119	151	270	119	4.1

PRESSURE RELIEF VALVE					
M	N	O	P	Q	Weight in kg
-	-	-	-	-	-
-	-	-	-	-	-
-	-	-	-	-	-
-	-	-	-	-	-
-	-	-	-	-	-
-	-	-	-	-	-
-	-	-	-	-	-
-	-	-	-	-	-
-	-	-	-	-	-
-	-	-	-	-	-
70	180	65	100	85	2.7
82	250	65	100	97	3.9
-	-	-	-	-	-
-	-	-	-	-	-
-	-	-	-	-	-
-	-	-	-	-	-
-	-	-	-	-	-
-	-	-	-	-	-
-	-	-	-	-	-
-	-	-	-	-	-
-	-	-	-	-	-

FEATURES

OPTIMISED APPLICATION

- A modular design
- A user-friendly interface
- Quick-fitting electric and pneumatic connections

ADDITIONAL FUNCTIONS

- A relief valve
- A linear sensor option
- Shut-off valve open sensor
- Various electronic modules

2 RANGES FOR ALL TYPES OF VALVES

■ ACS (Advanced Control System)

The ACS unit covers all the range of DEFINOX valves (excluding DCX3/4 fractional changeover valves and diaphragm valves with a fastening interaxial = 32)

■ ICS (Integrated Control System)

All the range excluding VDCI MC and DCX3/4 changeover valves with a nominal diameter greater than 80 mm

Unit
ACS

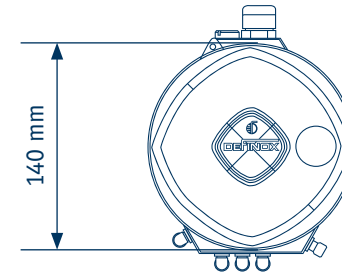
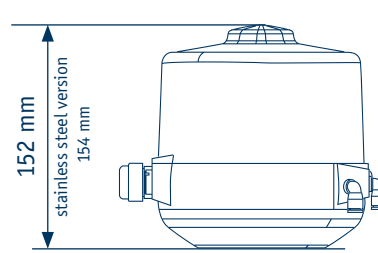

Unit
ICS

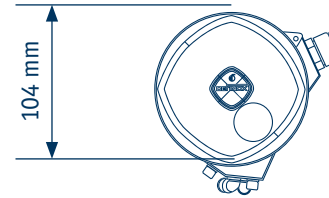
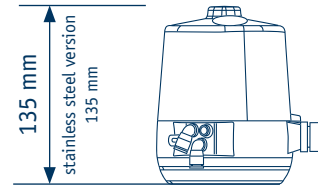

SPECIFICATIONS	ACS unit	ICS unit
Stainless steel cover	Yes, optional	Yes, optional
Relief valve	Yes	Yes
Point-to-point connections	24-48V AC/DC	24-48V AC/DC
Multi-voltage modules	PNP/NPN retro data	PNP/NPN retro data
AS-i connections	AS-i 2.1	AS-i 2.1
Sensors	Two TOR sensors with fine adjustment (range 80 mm) or one linear sensor	2 TOR sensors
Linear sensor	Resolution 0.2 mm Manual calibration Stroke 80 mm	No
External sensor	Yes	No
Electrical consumption (1 SV and 1 sensor activated)	< 70 mA in AS-i < 50 mA in 24V DC	< 70 mA in AS-i < 50 mA in 24V DC
Solenoid valves	One to three SV 3/2	One SV 3/2 or one SV 5/2
Pneumatic functions	NC, NO (only in one SV)	NC, NO and SE
Valve open/close speed control	Yes	No
Pneumatic connections	Quick 4/6	Quick 4/6
Air quality	Dry air filtered to 10µm 500 to 700 kPa (5 to 7 bar)	Dry air filtered to 10µm 500 to 700 kPa (5 to 7 bar)
Display	Yellow LEDs (3 or 7): I/O Red LED (1): Faults Green LED (1): Power supply	Yellow LEDs (3): I/O Red LED (1): Faults Green LED (1): Power supply
Operating temperature	0°C - 70°C	0°C - 70°C

TOR sensors



Linear sensor



Accurate detection

User interface





DEFINOX - DEFONTAINE Group
3 rue de la pépinière - Z.I. Nord
44190 GÉTIGNÉ - Cedex - FRANCE
Tel.: +33 (0)2 28 03 98 50
Fax: +33 (0)2 28 03 88 00
Info@definox.com
www.definox.com

DEFINOX - DEFONTAINE ITALIA srl
via Delle Industrie N°13/25-26
I-20020 ARESE - MILANO - ITALY
Tel.: +39 02/93 589 564 - Fax: +39 02/93 589 558
E-mail: etosatto@defita.com

DEFINOX - DEFONTAINE IBERICA SA
Poligono La Granja Parc. 15
E-31230 VIANA (Navarra) - SPAIN
Tel.: +34 948 646 133 - Fax: +34 948 646 155
E-mail: Franck-Albert@definox.com

DEFINOX - DEFONTAINE of AMERICA, inc.
16720 W. Victor Road - New Berlin
53151 WISCONSIN - USA
Tel.: +1 262 797 5730 - Fax: +1 262 797 5735
E-mail: lbuckett@definox-usa.com

DEFINOX Beijing Stainless Steel Equipment Ltd
No 18 Anningzhuang East Road - Haidian District
BEIJING 100085 - CHINA
Tel.: +86 10 6293 4909 - Fax: +86 10 6293 4835
E-mail: lk@definox.com.cn